



**MASSACHUSETTS
LOBSTERMEN'S
ASSOCIATION**

A LEADING Commercial Fishing Industry Association in New England

It's Almost Here!
**Annual Weekend
 & Industry Trade Show 2024**
 March 21-24, 2024

**SEE PAGES 17-28
 FOR MORE INFO!**



MARCH - APRIL 2024 NEWSPAPER • WWW.LOBSTERMEN.COM

MLA Files Lawsuits Against NOAA on Wedge Closure

Today, Friday, February 9, 2024, the Massachusetts Lobstermen's Association (MLA) filed a lawsuit against the National Oceanic Atmospheric Administration (NOAA) arguing that their Final Rule to make permanent the closure of the Massachusetts Restricted Area Wedge (Wedge) and include the Wedge in the larger Massachusetts Restricted Area (MRA) annually, from February 1 to April 30 is unlawful under the Consolidated Appropriations Act of 2023 and is a continuation of NOAA's unlawful conduct, which the United States Court of Appeals for the District of Columbia previously held "relied upon worst-case modeling that is 'very likely' wrong, based upon assumptions [NOAA] concededly does not believe are accurate" and relies upon legal reasoning which is "egregiously wrong."

For over 40 years, the MLA and commercial lobstermen have been at the forefront of North Atlantic Right Whale (NARW) conservation efforts. Despite our longstanding and demonstrated commitment to protecting these whales, NOAA continues to demand more from us. NARW conservation remains a top priority in all our endeavors. However, despite Congress's explicit directive to refrain from interfering with the lobster industry, NOAA has left us with no choice but to pursue

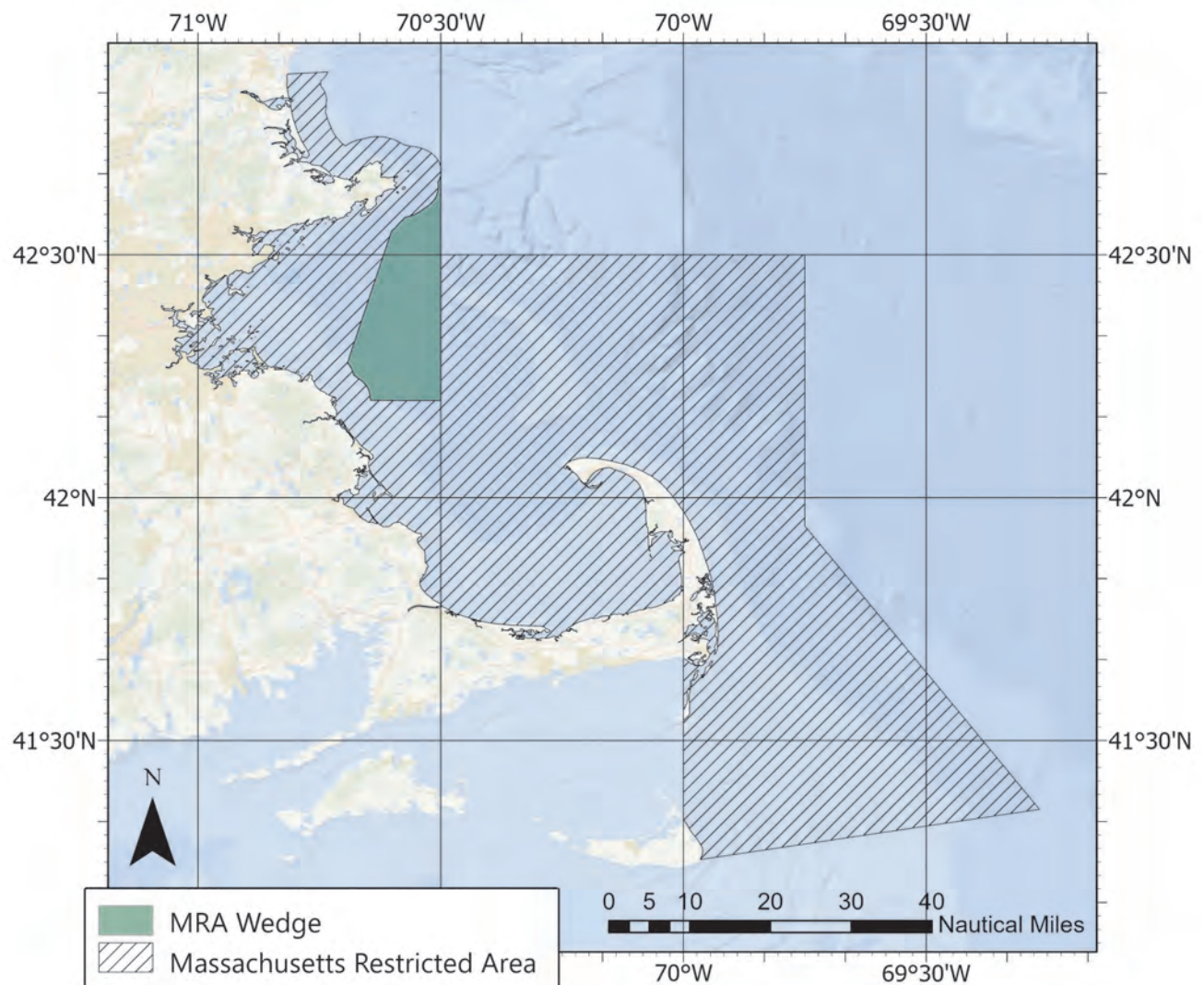

Rose Marine

www.rosesmarine.com

877-283-3334

Gloucester, Mass

Aqualoy Stainless Propeller Shafts & Accessories



WBM
WESTERN BRANCH METALS, LC

- Best Pricing
- Largest Inventory
- Fastest Turnaround

Call Peter Tetrault for a shafting quote

Hydraulic Valves in Stock



Commercial
DVA20 – 40 GPM
DVA35 – 60 GPM



Gresen25P W4
35 GPM – SS Spool



Cross SBA2
30 GPM - Replaces SPW4



Spiral Baffled Mufflers



Critical Grade, In-Line Mufflers



Stainless Steel In-Line Mufflers



Hydraulic Hoisting Winches

2850 lb & 10,000 lb
Hoisting Capacity
IN STOCK

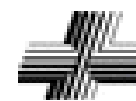

Trap Repair Wire

In Stock



6" - \$99
13" - \$159
16" - \$235

Prices based on current stock.

"TYTAN" 7/16" Sink Rope in Stock



\$169 per
1200' Coil

"Steel Haul" 3/8" Sink Rope in Stock



\$155 per
1200' Coil

Prices based on current stock.

MLA Sponsors

The following companies are proud supporting MLA members. We encourage our members to patronize them. If your company is not listed and you would like it to be, contact Tracey Abboud at 781-545-6984, ext. 2

ALIVE & KICKING LOBSTER

LOUIS MASTRANGELO
CAMBRIDGE, MA
617.876.0451

BOSTON LOBSTER FEAST

JEFF HAZELL
ORLANDO, FL
407.832.7322

BOSTON SWORD & TUNA

STEPHEN SCOLA
BOSTON, MA
617.946.9850

BROOKS TRAP MILL

STEPHEN BROOKS
THOMASTON, ME
207.354.8763
stephen@brookstrapmill.com

CAPE ANN MARINE

SALES & SERVICE
978.283.0806
capeannmarina.com

CAPE SEAFOODS BAIT DEALER

GERRY O'NEIL
GLOUCESTER, MA
978.479.4642

CAPE FISHERMEN SUPPLY

DAVE LIBBY
CHATHAM, MA
508.945.3501

CAPE TIP SEAFOODS

CHRIS KING
PROVINCETOWN/ORLEANS
508.487.0259 | 508.225.7221

CAPTAIN MARDEN'S SEAFOODS

KIM MARDEN
WELLESLEY, MA
781.329.7007 | 781.329.0792
captainmardens.com

CHERRY ST. FISH MARKET

DARRYL PARKER
DANVERS, MA
978.777.3449

CHRIS ELECTRONICS CORP.

FAIRHAVEN, MA
508.994.8257

EAST COAST SEAFOOD

SPIROS TOURKAKIS
LYNN, MA
781.593.1737

ECKLAND & BLANDO

SAM BLATCHLEY
BOSTON, MA 02110
617.217.6936
www.ecklandblando.com

ELECTRA-DYNE CO INC.

JUDY MACCAFERRI
PLYMOUTH, MA
508.746.3270

FARM CREDIT EAST

MIDDLEBORO, MA
508.946.4455

FISHER AIR FASTENERS

ED & CHRIS FISHER
PEMBROKE, MA
781.826.2522

FISHERMEN SERVICES

DONNA CHEPREN
781.545.5073 Ext. 16
fishermenservices.com

FLEET PROPELLER SERVICE

MIKE VALM
FAIRHAVEN, MA
508.979.8000

FRIENDSHIP TRAP CO.

FRIENDSHIP, ME
800.451.1200

HAMILTON MARINE INC.

56 US ROUTE 1 BYPASS
KITTERY, ME 03904
207.439.1133
hamiltonmarine.com

HARBOR FUELS

info@harborfuels.com
617.720.3835

HERCULES

JOHN REARDON
NEW BEDFORD, MA
508.993.0010

JAMES HOOK & CO.

ED HOOK JR.
BOSTON, MA
617.423.5500

KETCHAM TRAPS

HEATHER KETCHAM
NEW BEDFORD, MA
508.997.4787

KINGFISHER TRAP

CARL HOWARD
DENNIS, MA
508.385.5968

KING LOBSTERS

D.J. KING
BRANFORD, CT
203.488.6926

KING MARINE LLC

CAPT. GEORDIE KING
MARINE SURVEYOR
207.337.8706
kinggeordie@comcast.net

LOBSTER CRUISES

PAUL QUINTAL
PLYMOUTH, MA
508.746.5342

LOBSTER TRAP FISH MARKET

MONUMET BEACH, MA
508.759.6400
lobstertrap.com

LOBSTER TRAP CO.

MAC HAY
BOURNE, MA
508.214.3290 Ext. 101
lobstertrap.com

MARINE HYDRAULIC ENGINEERING

ROBERT CROWE
ROCKLAND, ME
207.594.9525 | 800.747.7550

MILTON CAT POWER SYSTEMS

MILFORD, MA
508.207.8542

MORTILLARO LOBSTER, INC.

VINCE MORTILLARO
GLOUCESTER, MA
798.281.0959

NAPA-CAPE COD

BILL DRINAN
FALMOUTH, MA
508-457-1734

NAVROC MARINE ELECTRONICS

JASON PHILBROOK
ROCKLAND, ME
207.596.7803

N.E. MARINE & INDUSTRIAL INC.

MIKE RICHARDSON (NH)
603.436.2836 | 781.834.9301
info@newenglandmarine.com

NEW ENGLAND PROPELLER

DOUG PECK
PLYMOUTH, MA
800.635.9504
neprop@aol.com

NORTH ATLANTIC POWER-TWIN DISC

SAM PROFIO
EXETER, NH
603.418.0470
sprofio@glpower.com

RFP LOBSTER BAIT

DICK PERENTZ
774.248.0292

RIVERDALE MILLS CORPORATION

NORTHBRIDGE MA
508.234.8715
riverdale.com

ROSES MARINE

GLOUCESTER, MA
877.283.3334
rosesmarine.com

SEA CLIFF LOBSTER

MANOMET, MA
508.224.5700

SPURS MARINE MANUFACTURING

PABLO SOSA
FORT LAUDERDALE, FL
800.824.5372

SUPERIOR LOBSTER

MARSHFIELD-SANDWICH
774.773.5048
www.superiorlobster.com

TWO COUSINS FISH MARKET

BRIAN O'DONOHUE
FREEPORT, NY
516.379.5065

WINDWARD POWER SYSTEMS

FAIRHAVEN, MA
774.992.0059
windwardpower.com

WOOD'S SEAFOOD

JAY KIMBALL
PLYMOUTH, MA
508.746.0261
www.woodseafood.com





**Published by the Massachusetts Lobstermen's Association, Inc.
8 Otis Place, Scituate, MA 02066**

– Published monthly –

Mailed to all paid members of the Massachusetts Lobstermen's Association

Newsletter Departments

Editor, Industry News, Notice Section, Editorial, Blog, Industry News, Promotions, Layout, Advertising:

Beth Casoni – Executive Director

Buy Sell Swap: *Tracey Abboud*

Newsletter Advertising Rates

The MLA Newsletter is published monthly (Please note that all pre-paid ads for last year will be honored)

\$50 – ¼ Page Ad

\$80 – ½ Page Ad

\$110 – Full Page Ad

Color Ads – + \$50 per ad

The Massachusetts Lobstermen's Association would like to welcome the following new members to the Association. Your Association will continue its efforts on your behalf to conserve the resource, protect your livelihood, keep you informed, promote the industry and provide you with increasing benefits as they are developed. MLA stands ready to help you in anyway, at anytime – just let us know how!
Safe on the water and good fishing!

NEW MLA MEMBERS:

JOHN CLAY

F/V: Preservance

Port: Danvers

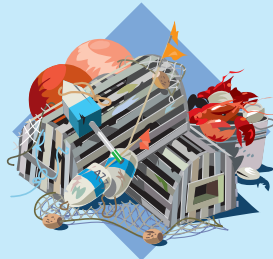

Make cleanup easy and fast.

Blast Away!
Onboard Pressure Washers
5.6 GPM @ 3,500 PSI

Our pressure washers come with everything you need, including 50' hose and wand with turbo nozzle.



Belt Driven



Hydraulic

Salt or Fresh Water

Coastal Hydraulics, Inc.

603-474-1914 • sales@coastalhyd.com

www.coastalhyd.com

28 Route 286, Seabrook, NH

OVER 20 YEARS EXPERIENCE ~ ALL MATERIALS & SIZES

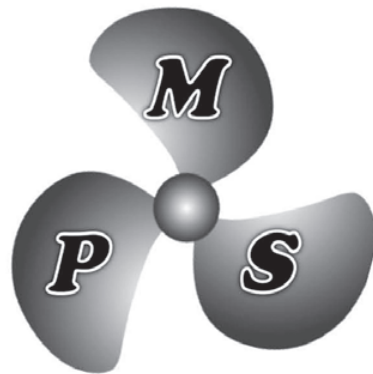

MARINE
PROPELLER SERVICE

**FOR FAST SERVICE
CALL MIKE @
508.979.8000**

marine.propeller128@gmail.com

**REPAIRS &
RECONDITIONING**
(Fast & Fully Insured)

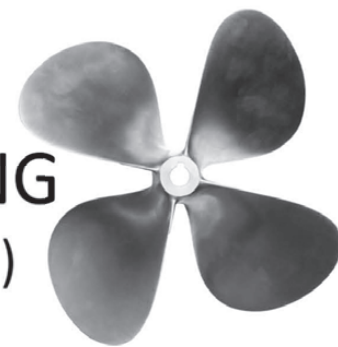

THE MOST RELIABLE PROPELLER SERVICE COMPANY ON THE SOUTHCOAST

74 MAIN STREET FAIRHAVEN MA 02719 508.979.8000 FAX 774.206.6449

OPEN HOUSE



HVM MAINE

HAMILTON
MARINE

BOATERSTORE™

April 6th to 14th

2024

Shop our *LOWEST PRICES* of the year!



800-639-2715 • hamiltonmarine.com

kittery • portland • rockland • searsport • sw harbor • jonesport • maine



Service Provider for MLA Non-Profit Boat Protection Cooperative Ltd.

MLA's #1 Commercial Boating Insurance Provider

Agreed Hull Value – Protection & Indemnity

Crew Coverage – Extended Policy Limits – Chartering

Marina Floaters – Multiple Fisheries & Deductibles

Call 781-545-5073 for a free quote

or

request a quote online at fishermenservices.com



As the HAULER TURNS



ANNUAL WEEKEND & INDUSTRY TRADE SHOW



The Massachusetts Lobstermen's Association (MLA) Annual Weekend & Industry Trade Show 2024 (AW24) is finally here, and we surely hope to see you there. The Annual Weekend Committee and MLA staff have been working tirelessly to bring you a full slate of seminars, industry vendors, and other important related vendors so that you can come learn about ALL of what is happening in your industry. All the Annual Weekend reservation forms can be found on the MLAs website: www.lobstermen.com

If you have not yet looked through the paper to see all the great things that are happening this year, please do so that you do not miss out on anything. This

year the MLA will have a "FREE" MLANPBPC insured member, in good standing (DUES MUST BE PAID IN FULL), raffle where you can win up to a \$2000.00 credit on your policy 7/1/24 – 6/30/25. There is no cash value on this raffle and if your policy is less than \$2000.00 it will be paid in full just for coming to the AW24 and filling out a "FREE" raffle. Please stop by the Fishermen Services Booth # 45 and talk to Donna about all things marine insurance and to fill out your raffle ticket.

There will be over 50 vendors at this year's event and we hope that you will stop by every booth to learn about what they are doing in your world of lobster, marine insurance, new technology,

new gear, health & safety, ocean sciences, NOAA, marine patrol, MADMF, legal support, offshore wind developers & mitigation applications, and the MLA booth to get your MLA gear and more.

This year the seminar schedule is full of ALL things lobster and lobstermen related. We are kicking this off with a MA Division of Marine Fisheries Public Hearing on Friday at 8:30am in the Centerville room to relaxing with Brian Robbins in the MLAs infamous Hospitality Suite. The full Public Hearing Notice is in this newspaper, and we hope that you will come participate in your fishery as the outcome will have an impact on your business.

To add even more excitement to this year's festivities, the entertainment on Friday and Saturday evening following dinner will have you singing along. On Friday evening following dinner you will be engaged with a full slate of trivia and Singo with lots of great prizes to be won. Who will be the first person to call out "SINGO" will it be you! On Saturday evening there be a whole lot of shaking going on around here with our Elvis impersonator. Sit back and enjoy the show, who knows maybe you will



feel the urge to get ups and shake your.....?

Lastly, we do not do this for ourselves, we do this for you as it takes an army of people to pull the MLA Annual Weekend & Industry Trade Show together. If you are looking for a great getaway with the family this event is for you. We look forward to seeing everyone there as this draws people from all around the world, Australia, England, Canada and, all around the Northeast. Stop by the MLA booth and say hello and let us know what more we can do to help you and your industry. See you there!

Safe on the water,
Beth Casoni
Executive Director



New England Marine Engineering & Supply, Inc.

Marine • Industrial • Commercial • Refrigeration

10 TON ELECTRIC TITANIUM RSW
INTEGRATED MARINE SYSTEMS

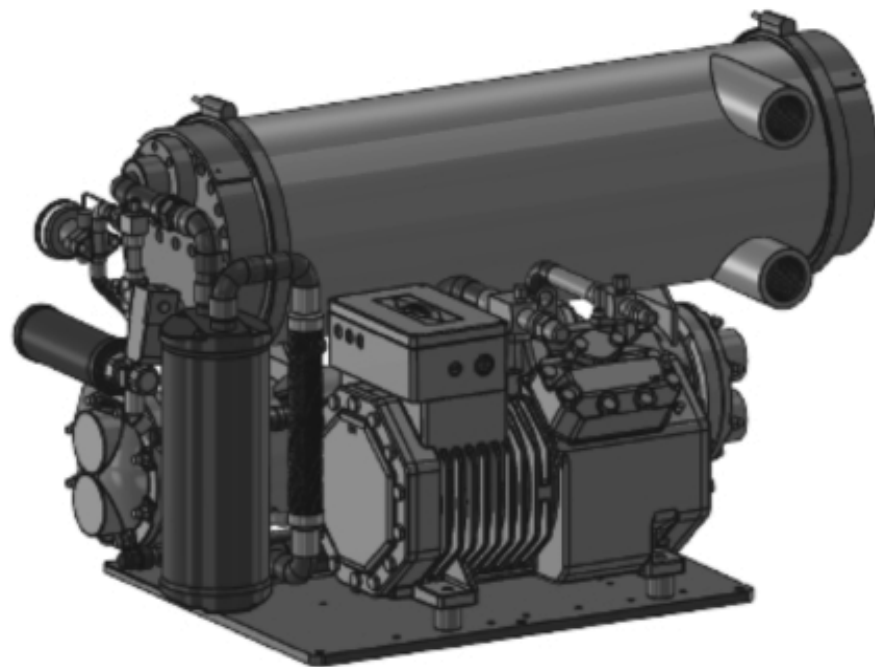

"New England Marine Engineering & Supply, Inc & Integrated Marine Systems, Inc is proud to announce & debut the new IMS 10 Ton Titanium Electric RSW at the 2018 Seafood Processing North America Show on March 11-13 Booth 1875. Come see us and be the first to view the latest IMS system to be introduced to the industry for the fishing vessels ranging from 40' - 80'.

It's going to be the talk of the show."

133 North Front Street, New Bedford, MA. 02740

www.nemesinc.com 1.800.540.8893

NOAA Closes the Wedge Permanently



On February 2, 2024, NOAA finalized the rule to make permanent the addition of the Massachusetts Restricted Area Wedge into the larger Massachusetts Restricted Area (MRA) annually, from February 1 to April 30. The wedge will now be closed to commercial trap/pot fisheries during this time in order to reduce the immediate high level of risk of incidental mortality and serious injury to North Atlantic right whales in this area as part of the Atlantic Large Whale Take Reduction Plan.

In 2024, this restricted area will go into effect 30 days after publication to provide fishermen notice to remove their gear. **This closure to persistent buoy lines will begin on Friday, March 8, 2024.** In 2025, the larger MRA will go into effect on February 1.

This rule permanently addresses the risk created by this open wedge when large numbers of right whales are using and transiting through the area while trap/pot gear is actively being fished or stored in preparation for the May 1 opening of federal waters within the Massachusetts Restricted Area.

This closure to buoy lines was requested by the Massachusetts Division of Marine Fisheries, which expressed concern about the high density of gear and whales in this area based on previous years' observations. The area was closed through emergency action in 2022 and 2023. This rule permanently address-

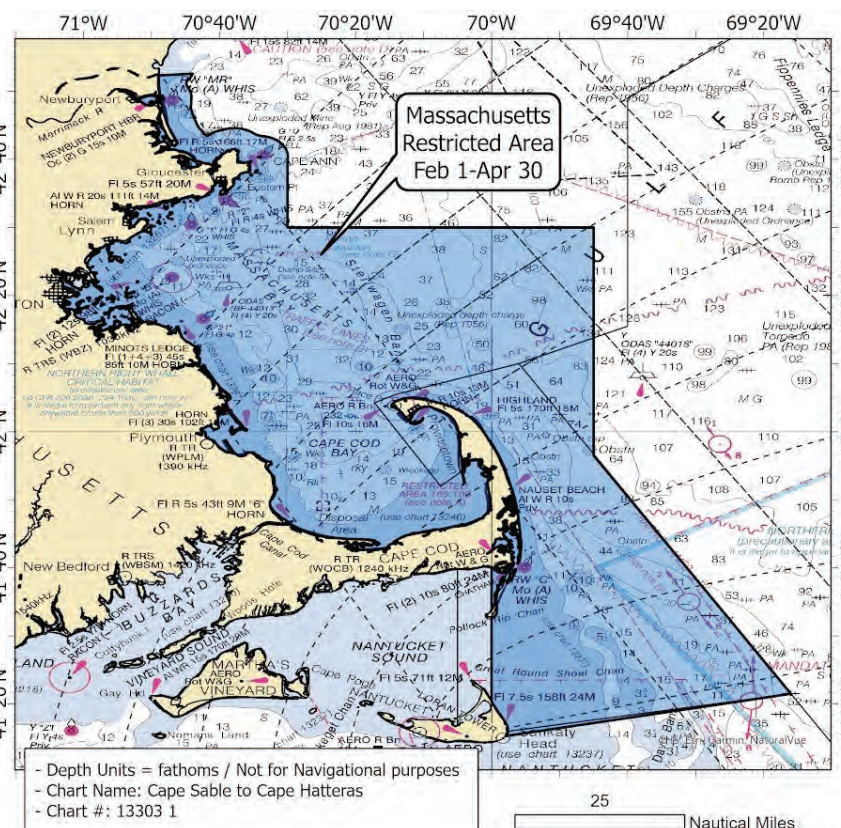

es the risk created by this open wedge when large numbers of right whales are using and transiting through the area while trap/pot gear is actively being fished or stored in preparation for the May 1 opening of federal waters within the Massachusetts Restricted Area. For more information on this closure and the Atlantic Large Whale Take Reduction Plan, visit our website: <https://www.fisheries.noaa.gov/new-england-mid-atlantic/marine-mammal-protection/atlantic-large-whale-take-reduction-plan>

Reducing the risk of entanglement of commercial fishing gear on the North Atlantic Right Whale is one of the overarching goals of NOAA Fisheries' North Atlantic Right Whale Road to Recovery:

<https://www.fisheries.noaa.gov/species/north-atlantic-right-whale/road-recovery>
The Road to Recovery framework is built on the foundation of the statutory requirements that NOAA Fisheries is charged with implementing under the Endangered Species Act and the Marine Mammal Protection Act. It describes our ongoing efforts to halt the North Atlantic right whale decline and encapsulates all of our ongoing work across the agency in collaboration with our partners and stakeholders to conserve and rebuild the population.

Jennifer S. Goebel
Marine Mammal Policy Analyst &
Regional Take Reduction Team Coordinator
Marine Mammal/Sea Turtle Branch
Protected Resources Division
Greater Atlantic Regional Fisheries Office
Gloucester, MA

MRA Wedge Area Coordinates		
Point	N Lat.	W Long.
MRA1	42°52.32'	-70°48.98'
MRA2	42°52.58'	-70°43.94'
MRA3	42°39.77'	-70°30'
MRA4	42°30'	-70°30'
MRA5	42°30'	-69°45'
MRA6	41°56.5'	-69°45'
MRA7	41°21.5'	-69°16'
MRA8	41°15.3'	-69°57.9'
MRA9	41°20.3'	-70°00'
MRA10	41°40.2'	-70°00'

Stellwagen Bank Advisory Committee Meeting #70

The Stellwagen Bank Advisory Committee (SAC) held its 70th meeting. The complexity of these meetings is robust and includes topics that are of simple, passing interest to some, to critical components of the future of our industry. The topics range from commercially viable seafood products to Maritime Heritage to offshore wind and much more. There is a fascinating array of individuals who donate their time and effort to these meetings, to the ideals of the sanctuary and to the successful operation thereof.

Those components with direct impact on our fishery include Offshore Wind, the North Atlantic Right Whale (NARW), forage species, specifically herring, the Wedge area, as well as other fisheries and interactions with those fisheries. Other important topics are educational outreach and mapping the Sanctuary. Maritime Heritage is fascinating yet doesn't have as much of an impact on fixed gear as it does on mobile gear.

Offshore wind and the NARW are the most ominous topics. We have seen the proposed lease areas for the wind projects. Although these proposed lease sites will be well to the east of the Sanctuary, the likely route for the transmission cables will likely pass through Stellwagen Bank Marine Sanctuary (SBNMS). There is an interesting overlap between Maritime Heritage here. The Maritime Heritage team is currently in the process of side-scan sonar, mapping as much of the Sanctuary as possible. This comes at an opportune time. The mapping program will be utilized in the decision-making process of locating potential corridors for these transmission lines.

There continues to be lots of talk about partnering with Bureau of Energy Management, (BOEM) for information purposes. The SAC is considering the prospect of offering a non-voting seat to BOEM for this purpose. This would be beneficial in terms of the process of locating transmission lines as well as streamlining information flow between the SAC & BOEM. Information is critical here. It was noted from the Mobile Gear Seat, Mark Gustafson, that there was a decision to not run a cable through Coxes Ledge because of its critical habitat status. This decision was rescinded and the process of running that cable through Coxes Ledge is now underway.

The SAC will actively coordinate with BOEM on a multitude of issues: permitting in the Sanctuary, routing, traffic management, on the national level, to include Offshore Wind transmission lines. It was noted that the companies responsible for the construction of Offshore Wind projects want nothing to do with the Sanctuary and its rules, as far as can be avoided.

Regarding NARW, we continue to be given the back seat based on the erroneous narrative on the subject. SBNMS supports increasing the closure to include the Wedge Area and to extend the closure north to the New Hampshire border and east to Area 3. It is my understanding, this extension of the closure would be in contravention to the Consolidated Appropriations Act, signed into law by President Biden in 2022, that stated, basically, no new rules or regulations for the Lobster and Jonah Crab fisheries until, at least, 2028. No one seems to have any concerns about this inconvenient fact. Some of the basic, exculpatory facts as to why WE are not to blame, were mentioned, as a note, but the recommendation had already been made by the SBNMS.

SBNMS has started a program that utilizes AIS to broadcast real-time data as to the location of NAWRs. As of now, there is only one AIS tower that has the additional equipment necessary for this "product". Superintendent, Peter DeCola, expressed high confidence in this product, noting that it would be an expensive rollout but could be utilized along the entire east coast. There's some interesting potential here as well as some potential downside for the fleet. I will do my best to keep you informed as I learn more.

As for the unfortunate NARW that ended up on Martha's Vineyard, the propaganda machine is fully engaged. We know it isn't us, but the public does not. Again, it was noted that it is unlikely that Massachusetts, or for that matter, any of the lobster fleet had anything to do with this entanglement. Kelly Whitmore of the Division of Marine Fisheries noted that the line did not have the color marking scheme used for Massachusetts and was not line that would be likely used in our fishery. She also noted the rollout of the Massachusetts specific, 1,700 lb., break-away, red line with the Massachusetts tracer ribbon embedded in it.

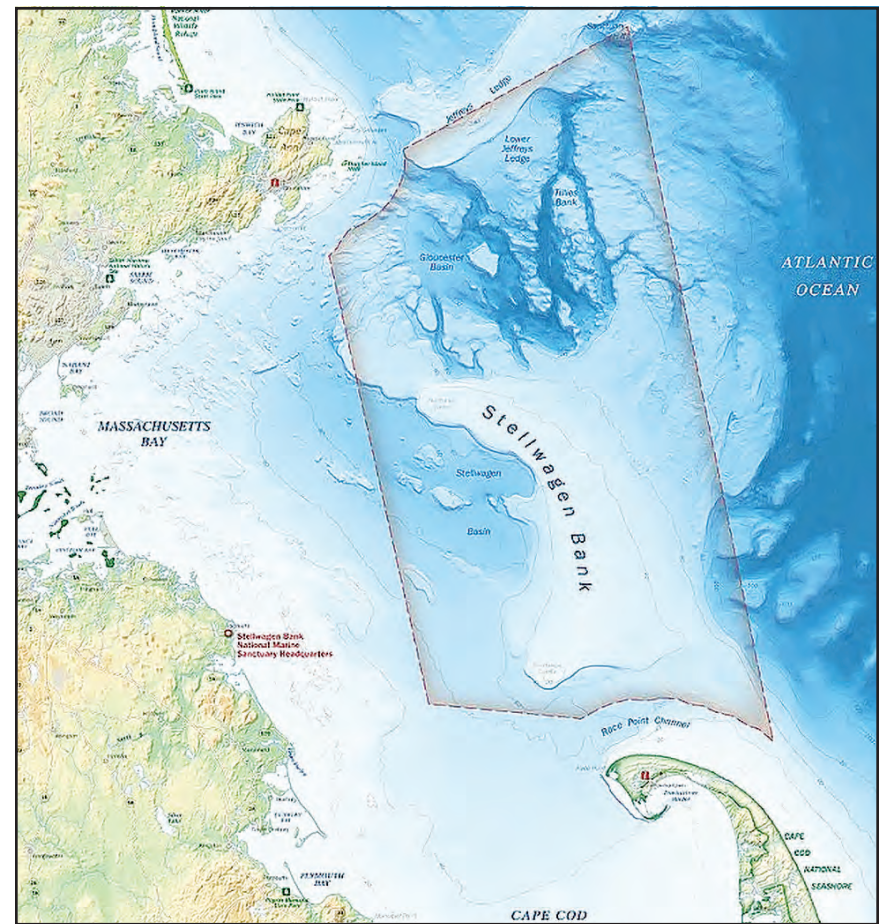

Forage species were discussed to a limited extent: Herring and sand lance. The concern for sand lance revolved around the scallop fishery and its destructive impact on the sandy habitat required by the sand lance for reproductive purposes. There have not been any decisions, rules, or regulations on this matter. For now, it is only a discussion as the "experts" try to determine the overall impact of the sand lance as a forage species. Amendment X is on the table regarding spatial and temporal management. There will be a panel discussion on the herring amendment at the Maine Fishermen's Forum at the beginning of March.

Maritime Heritage is wound fully throughout the fabric of SBNMS. The history of the sinking of the Portland is going to be presented in the upcoming months in Portland, ME. The discussion will include the wreck itself and the timeline as well as the overall impact on the community of Portland. Probably the most famous wreck on the Bank, the Portland has been photographed and studied quite extensively. With the data the Sanctuary scientists have retrieved, they have been able to build a 3D model of the ship. It

is wildly impressive. The location of the vessel has remained tightly guarded to keep folks away from it. What I can say is that it has some nets on it and is relatively very deep. I, for one, am very interested in seeing the final presentation of the Portland wreck.

The educational and outreach initiatives of the Sanctuary are quite extensive. The biggest push in years is the upcoming construction of a facility in Provincetown. This should be a huge win in terms of bringing further awareness to Stellwagen and the amazing biodiversity that thrives there.

Two final notes: Deputy Superintendent, Ben Haskell will be leaving in July. Ben has dedicated 31 years of his life protecting Maritime Heritage and fighting to preserve nature! There is a vacancy for the Fixed Gear Alternate seat at the SAC. If anyone is interested, please contact Eric Meschino, Beth Casoni, or SBNMS directly to inquire. The more we stay engaged, the better chance we will be able to move the needle in our favor.

Eric Meschino
SAC-Commercial Fixed Gear Rep

AQUAMESH®

AMERICAN MADE designed for the LONG HAUL

Since 1980 Aquamesh® has revolutionized the marine industry. It's designed to be weather and corrosion resistant to withstand the harshest marine conditions.

Designed and manufactured in Massachusetts with pride, by lobstermen who know the superiority of Aquamesh®

- Proven Quality and Durability
- Precision Engineered
- Fastest Fishing Mesh
- Unmatched Corrosion Resistance
- The Highliner's Top Choice

Rebekah,
3rd generation lobsterman.



Aquamesh® | Manufactured by Riverdale Mills
riverdale.com | sales@riverdale.com | 1.800.762.6374



RESEARCH FROM AMERICAN LOBSTER INITIATIVE

Juvenile Lobster **PREDATION**

By Simonne Dodge, Jennie Rheuban, & Stephanie Murphy | WHOI Sea Grant
March-April 2024

A research team asks: Who's eating young lobsters?

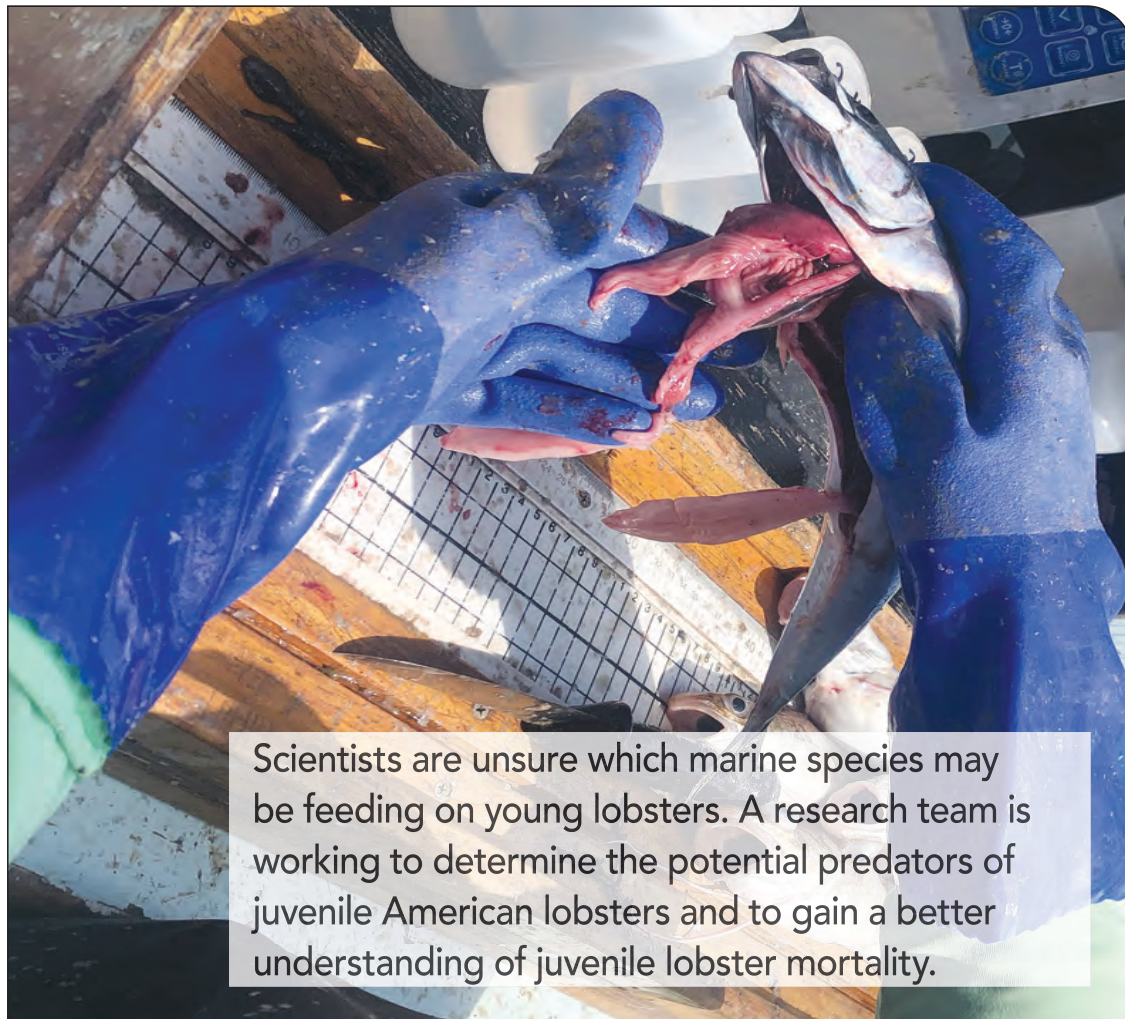

Scientists are unsure which marine species may be feeding on young lobsters. A research team is working to determine the potential predators of juvenile American lobsters and to gain a better understanding of juvenile lobster mortality.

The dissection of an Atlantic mackerel on a research vessel. Credit: Amalia Harrington, ME Sea Grant



Credit: Amalia Harrington, ME Sea Grant

Samples of marine organisms from a marine survey collection

EXPLORE the PROJECT

Atlantic cod, red hake, white hake, Atlantic halibut, and Atlantic mackerel have been documented eating juvenile lobsters in the Gulf of Maine, but the extent to which lobsters make up their diet is unknown.

The research team has been examining the stomach contents of these species to look for juvenile lobster remains and noting the developmental stage of any whole lobsters. Black sea bass and striped sea bass may now also pose a threat to juvenile lobsters, so the team samples their stomach contents when they are encountered.

To explore more research stories from American Lobster Initiative, visit our StoryMap collection:

<https://arcg.is/1CHT1j>



RESEARCH FROM AMERICAN LOBSTER INITIATIVE

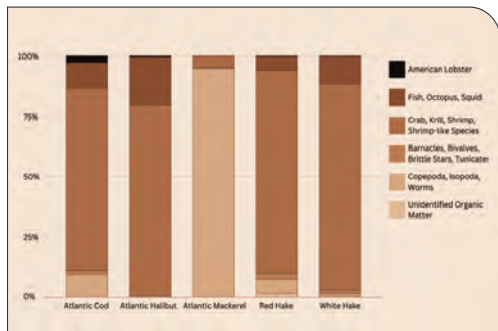

Prey found in predators' diets from fall 2021 to fall 2022

Data: R. Peters, MEDMR; Graph: S. Dodge



A juvenile lobster in an Atlantic cod's stomach during a dissection

Credit: Rebecca Peters, MEDMR



Credit: Rebecca Peters, MEDMR

READ the RESULTS

Preliminary results from fall 2021 through fall 2022 surveys found lobsters in the diets of Atlantic cod, Atlantic halibut, red hake, and white hake. However, they were in very low abundance in comparison to other prey items found in the fish stomachs.

This project is ongoing, and more results will be available once all survey data is collected and analyzed. (*These results are preliminary and subject to change with peer review.)

UNDERSTAND the IMPORTANCE

Little is known about the predators of American lobster in coastal Maine and New Hampshire waters, making it difficult to accurately estimate mortality of juvenile lobsters.

Not only will this study provide insight into the species that are feeding on lobster, but it will also expand our knowledge of the overall diets of the seven fish species involved in this study. All of this information can be used to obtain a better understanding of ecosystem dynamics in the inshore waters of the Gulf of Maine.

Rebecca Peters, MS PRINCIPAL INVESTIGATOR

Rebecca Peters is a marine resources scientist and inshore trawl survey supervisor at the Maine Department of Marine Resources.



We welcome your feedback.
Email us at lobster@whoi.edu

RESEARCHER HIGHLIGHT



Credit: Rebecca Peters, MEDMR

Rebecca Peters – Maine Department of Marine Resources

Yearly travel to the beaches of Delaware sparked Rebecca's early passion for marine science. As an undergrad, she focused on understanding the interconnections within ecosystems, and as a graduate student at the University of Maryland, she studied habitat use of black sea bass. During

a Knauss Fellowship with the NOAA Fisheries Office of Science and Technology, Rebecca became interested in how science informs policy & management. Rebecca currently leads the Maine-New Hampshire Inshore Trawl Survey in her position with Maine's Department of Marine Resources.

Bill Tackles Problem of Abandoned Fishing Gear

Tarr Takes Next Major Step to Protect North Atlantic Right Whales, Marine Environment, and Commercial Fisheries



BOSTON – Having successfully pursued significant measures over the last several years to protect endangered North Atlantic Right Whales in Massachusetts, State Senate Minority Leader Bruce Tarr (R-Gloucester), the Senate Chair of the legislature’s Coastal Caucus, is taking another major step, with other members of the caucus, to protect the whales, the marine environment, and the state’s commercial fisheries, by filing SD.3009, “*An Act Relative to Abandoned Fishing Gear*,” which would establish the legal framework for this chronic nemesis to be removed from the state’s waters through appropriate regulations promulgated by the Massachusetts Division of Marine Fisheries. This bi-partisan, bi-cameral legislation has garnered early co-sponsorship from Senator Patrick O’Connor (R-Weymouth) and Representatives Ann Margaret Ferrante (D-Gloucester) and Kathleen LaNatra (D-Kingston).

“Left unchecked, abandoned fishing gear poses several threats to our marine environment and ecosystems,” said Tarr. He added that, “It ‘ghost fishes,’ increasing mortality without any harvest benefit, it presents a major risk for entanglement for right whales and other species, it clutters and pollutes the ocean floor, and it presents ongoing problems for coastal communities that have

to deal with this form of pollution when it washes ashore and must be collected and disposed of before it does further damage.”

“Maintaining clean waterways, coastlines, and fishing areas is incredibly important for our oceans and the marine environment,” said O’Connor. “Our commercial fishing partners have been strong advocates for their industry and this legislation provides a solution to remove debris and gear that may wash ashore that has been difficult to remove in the past.”

“Our communities depend on a clean and unobstructed ocean. Abandoned and unused fishing gear threatens navigation of vessels, as well as the travel lanes of some of our marine species,” said Ferrante. “This bill allows for the removal of legitimately abandoned fishing gear, protects marine life, while maintaining the private property rights of our fishermen and lobstermen.”

“Abandoned fishing gear presents a clear threat to the health and safety of marine wildlife and our ocean ecosystem as a whole. Yet, current statute prevents us from cleaning up our oceans and being proper stewards of our most important and vital resource,” said LaNatra. “I am proud to co-sponsor this legislation to ensure that our oceans and waterways are not being cluttered by gear that is no longer providing any economic benefits to the Commonwealth, and only adds to the threats that our marine ecosystems face today.”

Currently, because Massachusetts law treats abandoned gear as private property even when it is unclaimed and no owner can be identified, state regulators at the Division of Marine Fisheries (DMF) cannot effectively develop and implement regulations to facilitate the systemic removal of the gear from state waters despite the clear and multiple environmental threats it poses on a continuing basis. SD.3009, “*An Act Relative to*

Abandoned Fishing Gear” would reframe and restructure relevant portions of state law to allow the agency to engage the public process of creating new regulatory measures to allow the gear to be responsibly removed while respecting private property considerations.

“Derelict fishing gear has no place in our environment. Over 9% of fishing gear is lost or abandoned annually, but outdated state laws prevent efforts to recover it. This is a persistent problem—abandoned gear is a threat to endangered right whales, a safety hazard for mariners, a nuisance on our beaches, and a costly burden for municipalities to clean up,” said Department of Fish and Game Commissioner Tom O’Shea. “Thank you to Senator Bruce Tarr for leading this effort to modernize state law and streamline our department’s efforts to recover derelict gear.”

The filing of the bill comes following months of research on the subject by the DMF, and collaboration with Tarr and other legislators, with a focus on prioritizing the protection of right whales while recognizing the high price currently being paid by those in the commercial lobster fishery to protect this endangered species through the extreme economic sacrifice of enduring fishery closures that last for months and prevent harvesters and others from being able to earn a living.

“Abandoned and lost fishing gear can persist for many years on the ocean floor, in the water column, and on our beaches,” said Massachusetts Division of Marine Fisheries Director Daniel J. McKiernan. “We are grateful to the lobster industry leaders and conservation community leaders who came together with us to devise strategies to dispense of this marine debris and minimize the ecological impacts that it could create.”

“The Massachusetts Lobstermen’s Association (MLA) is proud to sup-

port the Abandoned Gear Bill that will help modernize the law to help local communities with their beach cleanup efforts,” said Executive Director of the MLA, Beth Casoni. “The commercial lobster industry also helps with many of these cleanup efforts to maintain clean beaches for everyone to enjoy. We look forward to seeing this bill through to the end.”

The filing of the bill follows several other initiatives spearheaded by Tarr, with the overwhelming support of the legislature, to protect right whales and support the state’s commercial fishing industry over the past several years.

They include:

FUNDING FOR DIRECTED PATROLS BY THE MASSACHUSETTS ENVIRONMENTAL POLICE (MEP) OF AREAS CLOSED TO FISHING DUE TO THE POTENTIAL FOR RIGHT WHALE PRESENCE

Tarr secured \$250,000 in Fiscal Year 2022, and again in Fiscal Year 2024 for these targeted efforts to prevent harm to right whales during the peak times for their presence in Massachusetts waters. These efforts came at the request of the Massachusetts Lobstermen’s Association, because of the organization’s concern that injuries not related to active fishing could occur even as lobster harvesters were making the significant economic sacrifices caused by state waters being closed to lobstering.

The funding from this program has been highly effective in protecting right whales through several measures, including:

PREVENTION OF ILLEGAL ACTIVITIES:

Increased patrols act as a deterrent to illegal activities in closed areas. These areas are designated to protect right whales during critical times, such as calving and feeding. Patrolling helps enforce regulations and prevents unauthorized fishing activities, reducing the risk of en-

tanglement and collisions between whales and fishing gear.

REDUCTION OF ENTANGLEMENT RISKS:

Closed areas are often established to minimize the risk of entanglement, a significant threat to right whales. Fishing gear, such as lines and traps, can pose a danger to whales if they become entangled. Patrolling closed areas ensures that fishing activities comply with regulations, reducing the likelihood of abandoned or improperly managed gear that could entangle right whales.

ENHANCED RESPONSE TO GEAR DEBRIS:

Increased patrols enable authorities to respond promptly to any fishing gear debris found in closed areas. Abandoned or lost gear, known as fishing gear debris, can continue to pose risks to marine life. Patrols help identify and remove such debris, preventing potential harm to right whales and other marine species.

PROTECTION OF CRITICAL HABITATS:

Closed areas are often designated in important habitats for right whales, such as calving grounds and feeding areas. Patrolling ensures that these critical habitats remain free from disturbances that could disrupt

the natural behavior of the whales. Protecting these areas contributes to the overall well-being and reproductive success of the right whale population.

RESEARCH AND MONITORING OPPORTUNITIES:

Patrolling closed areas provides opportunities for research and monitoring efforts. Observations made during patrols contribute valuable data on the behavior, health, and distribution of right whales. This information is essential for implementing effective conservation measures and adapting strategies to better protect the species.

FUNDING FOR GEAR DESIGNED TO PROTECT RIGHT WHALES

In Fiscal Year 2023, Tarr authored successful legislation to create a program for grants to lobster harvesters for replacement gear required for the protection of right whales. The grant program, funded at \$500,000, provided the funds needed for harvesters to be able to afford the substantial cost of such essential fishing gear as “weak rope,” constructed to break in the event of high stress due to a whale entanglement.

DMF awarded approximately

\$475,000 to 162 Massachusetts lobster fishers to purchase whale safe rope and gear marking supplies. The awards ranged from \$1,000 to \$3,025.

ENDANGERED SPECIES: NORTH ATLANTIC RIGHT WHALES

The North Atlantic right whale is recognized for their massive size, distinctive callosities on their heads, and broad, deeply notched tails. These marine giants once thrived in the waters along the eastern coast of North America; however, their population has dwindled to critically low numbers, making them one of the rarest large whale species on the planet.

One of the defining features of North Atlantic right whales is their annual migration in which they embark on a seasonal pilgrimage, covering vast distances from their feeding grounds in chilly northern waters to their calving areas in the warmer, southern regions. The North Atlantic right whale’s migration typically occurs in late fall and early winter when they travel southward to give birth and nurture their calves in the subtropical waters off the southeastern United States.

During the spring (March to

June), North Atlantic right whales can be spotted in the waters of New England as they migrate northward. This period coincides with their return journey from their calving grounds in the warmer southern waters. As the waters in New England begin to warm up, these whales travel along the Atlantic coast, feeding on plankton-rich areas.

It is important to note that the exact timing of their arrival and departure may vary each year, influenced by factors such as oceanographic conditions and the availability of their primary food sources. Understanding the intricacies of their migration patterns and addressing the threats they encounter during these journeys are critical steps in the conservation efforts, which aim to track and protect these whales during their migrations, especially given the various threats they face in their journey, such as vessel strikes and entanglement in fishing gear.

Additional Resources:

malegislature.gov/bills

www.mass.gov/orgs/division-of-marine-fisheries

lobstermen.com

www.fisheries.noaa.gov/species/north-atlantic-right-whale



Encore Hartco Tools & Clips
Stanley Spenax Tools & C-Rings
Wematic Tools & D-Rings
Simonds Pneumatic Wire Cutters
Spotnail Staplers & Staples



(781) 826-2522
Fax (781) 826 5252
www.fisherairfasteners.com
chris@fisherairfasteners.com

Complete Parts Inventory
Tool Repair Service

Lawsuit

FROM PAGE 1

litigation. Let it be clear: litigation is not our preferred course of action, particularly as a self-funded fishing organization with limited resources. Nonetheless, we refuse to stand by while NOAA unlawfully jeopardizes our livelihoods. We have reached a breaking point, and we will not tolerate any further unjust attacks on our industry. Enough is enough!

MASSACHUSETTS NARW CONSERVATION TIMELINE

- 1935 - International ban on hunting whales goes into effect
- 1970 - North Atlantic Right Whales listed as endangered
- 1996 - NOAA implements the Large Whale Take Reduction Plan
- 1997 - MA requirement for "break-away" features in gillnets and trap/pot buoy lines Seasonal ban in Cape Cod Bay for gillnets and on use of floating rope between traps
- 1997 - Dedicated aerial surveys begin in Cape Cod Bay
- 2004 - Year-round ban on floating

rope between traps in Cape Cod Bay

- 2007 - Year-round ban on use of floating rope between traps statewide
- 2014 - MA Restricted Area is created a 3-month closure Feb-April to 3,071 sq. miles
- 2015 - 3-month (Feb/Apr) closure to all pots/traps in the MA Restricted Area
- 2016 - 3 months (Feb/Apr) closure to all pots/traps in the MA Restricted Area
- 2017 - 3-month (Feb/Apr) closure to all pots/traps in the MA Restricted Area PLUS 4-day extension of the gear closure in Cape Cod Bay
- 2018 - 3-month (Feb/Apr) closure to all pots/traps in the MA Restricted Area PLUS a 15-day extension of the gear closure and speed restriction (10 mph) for small vessels in Cape Cod Bay
- 2019 - 3-month (Feb/Apr) closure to all pots/traps in the MA Restricted Area
- 2020 - 3-month (Feb/Apr) closure to all pots/traps in the MA Restricted Area
- 2021 - ALL traps set in Massachu-

setts' waters are subject to a maximum buoy line diameter. The maximum buoy line diameter for commercial trap gear is 3/8-inch, whereas it is 5/16-inch for recreational lobster and crab trap gear.

- 2021 - South Island Restricted Area is implemented closing over 5,500 sq. miles

The Massachusetts Lobstermen's Association was established in 1963 by the fishermen, for the fishermen, and is presently one of the oldest leading commercial fishing industry associations in New England. On behalf of the 1,800 members, the MLA works to maintain both the industry and the resource. The MLA strives to be proactive on issues affecting the lobster industry and is active in the management process at both the state and federal levels. The MLA communicates with its members through a monthly newspaper, weekly email, Facebook, and attendance at industry meetings. For the past 61 years, the MLA has become a trustworthy voice for the industry on important issues and is looked to by both the fishing industry and the management community for leadership and guidance.

The MLA remains steadfast in its commitment to safeguarding the livelihoods of the 650 responsible commercial lobstermen remaining in the Commonwealth. That's precisely why we are contesting the legality of the Wedge closure. We understand the critical importance of the approximately 250 square miles Wedge area for these lobstermen, particularly during these challenging economic times and amidst historically low (indeed, zero) North Atlantic Right Whale sightings. Our belief in the necessity of this area is not unique to the MLA alone; Congress itself prohibited NOAA from closing the Wedge through the Consolidated Appropriations Act of 2023. NOAA cannot disregard the will of Congress and target our lobstermen without facing a response from us.

The Massachusetts Lobstermen's Association is a member-driven organization that accepts and supports the interdependence of species conservation and the members' collective economic interests. We will continue to fight for reasonable, sensible, and legal measures to protect the NARW. The Wedge Closure is not reasonable, sensible, or legal.

Are you thinking of buying or selling?

Boats | State and Federal Permits | Complete Businesses

ATHEARN MARINE AGENCY, INC.



SERVING FISHERMEN SINCE 1946

Tel: (508) 999-4505
 Email: sales@athearnmarine.com
 www.athearnmarine.com

10 Union Wharf, Fairhaven, MA 02719



YOUR COMPLETE EVENT GUIDE INSIDE!

See pages 17 - 28 for this year's full slate of fun offerings & informative activities



2024 Annual Weekend & Industry Trade Show

March 21-24, 2024

(Vendor setup is on the 21st)

AT THE EMERALD RESORT & CONFERENCE CENTER

35 Scudder Avenue, Hyannis, MA 02601 | www.theemeraldresort.com



EXHIBITOR LAYOUT / HOTEL MAPS

Second Floor Meeting Rooms

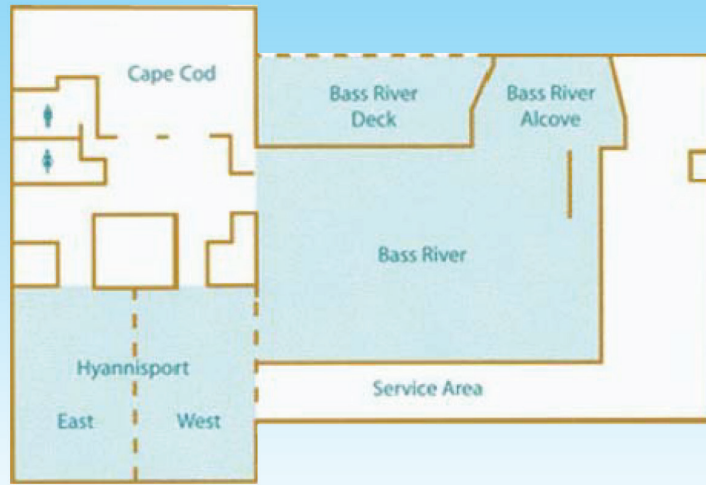

Conference Center Meeting Rooms

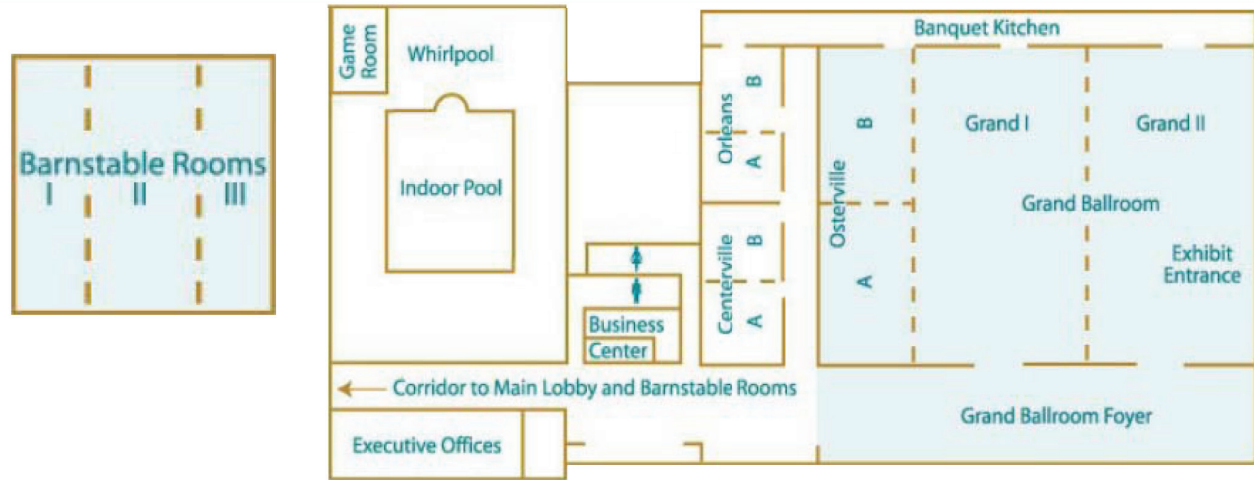

Grand Ballroom Detail - Vendor Booth Assignments

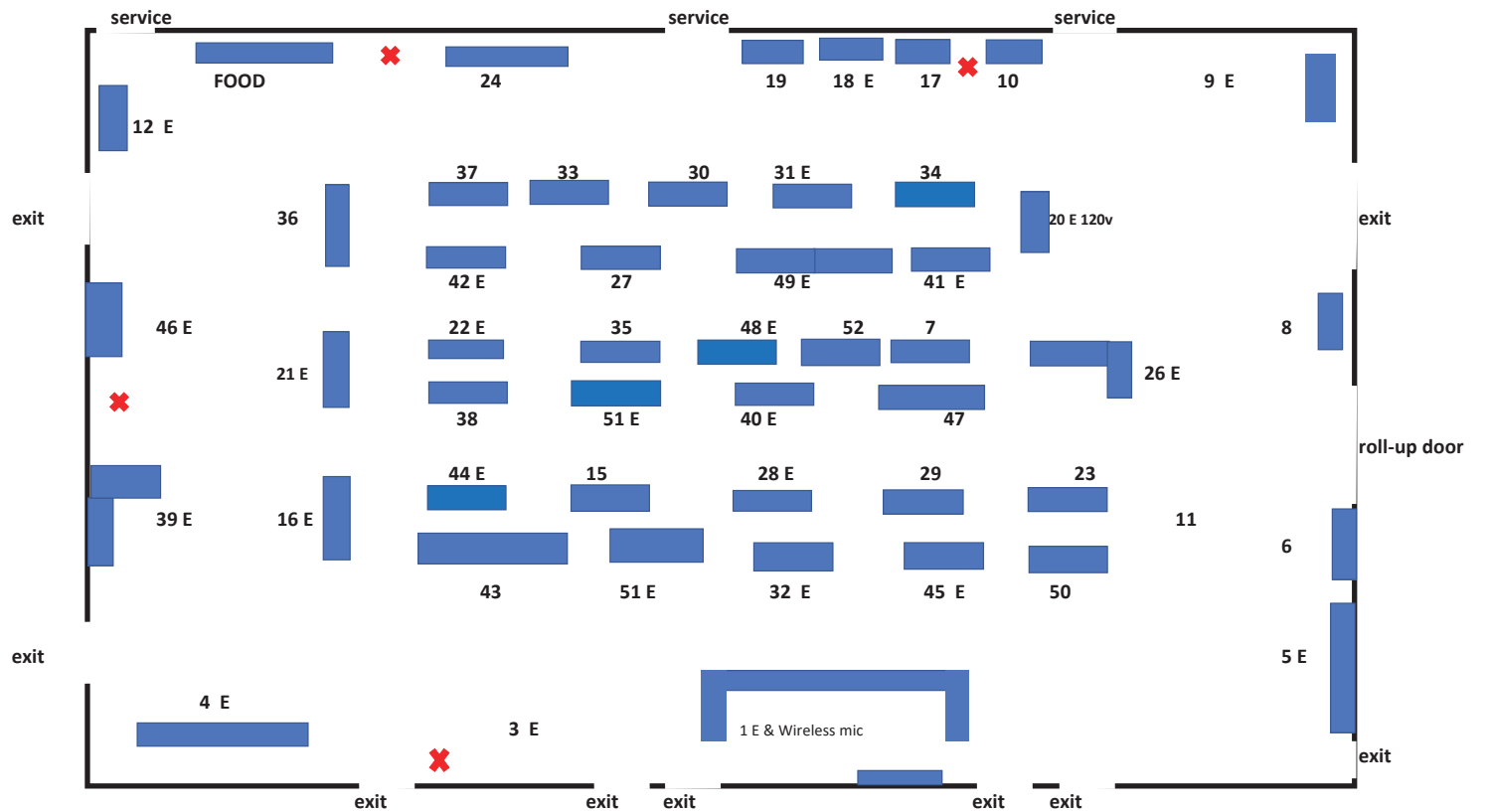



FULL LIST OF 2024 EXHIBITORS

<i>Company Name</i>	<i>Types of Items on Display</i>	<i>Booth Number</i>
Athearn Marine Agency Inc.	Commercial Vessel & Permit Brokerage	3
Avangrid	Offshore Wind Developer	27
Bluehome	Coastal Artificial Reefs.....	49
Brooks Trap Mill	Lobster Traps & Marine Supplies.....	4
Center for Coastal Studies	Marine Debris-Marine Fisheries-rescue.....	33
Chris Electronics	Marine Electronics.....	16
Com. Fisheries Research Foundation	Collaborative Research	29
Commercial Fisheries News	Commercial Fishing Publication	34
Deckhand Electronic Logbook	Electronic Logbooks	39
Eckland & Blando LLP	Legal Services.....	50
Fishery Friendly Climate Action	Climate Action	35
Fishing Partnership Support Service	Health Services & Safety Training.....	5
Friendship Trap Co.	Lobster Traps & Marine Supplies.....	9
Gulf of Maine Lobster Foundation	Lobster Research.....	30
Hercules SLR US Inc.	Marine Supply & Safety	36
Ithaca Clean Energy	Water Front Mobile App.....	51
Ketcham Traps	Lobster Traps & Marine Supplies.....	11
Lobster Foundation of Massachusetts	Educational and Scientific Research & Outreach.....	1
Lobster Institute	Lobster Research.....	7
MA Division of Marine Fisheries	Fisheries Management.....	18, 17, 10
MA Environmental Police	Law Enforcement.....	19
MA Lobstermen's Association	Commercial Fishing Organization	1
Mack Boring & Parts Co.	Diesel Engines & Parts	24
Milton CAT	Marine Engine	8
MLA Fishermen Services	Commercial Marine Insurance	45
N.E. Center of Occupational Safety	Commercial Fishing Safety.....	6
N.E. Fishermen Stewardship Assoc.	Fishing Organization	12
Navroc Marine Electronics	Marine Electronics.....	26
NE Young Fishermens Alliance	Advocacy for Commercial Fishing.....	38
Neptune	Decommisioning of Neptune LNG.....	34
NERACOOS	Ocean Data.....	31
Net Your Problem LLC.	Fishing Gear Recycling Service	37
New England Marine Engineering	Marine Industrial Equipment.....	20
New England Propeller	Boat Propellers & Accessories.....	32
NOAA Greater Atlantic Regional	Information & Outreach Material	41
NOAA N.E. Fisheries Science Center	NOAA Fisheries Outreach	42
Northeastern University	Marine & Environmental Sciences Research.....	44
Orsted US	Offshore Wind Developer	34
Patsy Kane Nautical	Nautical Jewelry	23
Power Products	Volvo Penta Engines & Parts.....	46
Responsible Offshore Development Alliance	Offshore Wind Commercial Fishing Organization	15
Riverdale Mills	Aquamesh Marine Wire	22
Saeplast Americas Inc.	Insulated Containers.....	47
Southcoast Wind	Offshore Wind Developer	48
Superior Lobster	Lobster Dealer	43
The Shaw Fund for Mariners' Children	Fund to Support New England Fishermen and Others Who Work at Sea	52
U.S. Coast Guard	Fishing Vessel Safety.....	21
Vineyard Wind	Offshore Wind Developer	28
WHOI Sea Grant	Oceanographic/Coastal Research/Education/Outreach.....	40



New England Marine & Industrial
www.newenglandmarine.com

Lobster Bands



We carry:
Sheddar
Standard
Cold Water Sheddar
Jumbo

Buy them by the 1 pound bag, by the case or by the pallet. We also offer wholesale and volume discounts. Call and ask to speak to a salesman.



Dayglo &
Flexabar
Buoy Paint



Buoys:
Sea Alex
Polyform
Sea Master

Riverdale/Aquamesh Trap Wire

- Large inventory of trap wire in store
- Variety of sizes and colors available
 - Some trap kits in stock
- Order any size trap kits you may need

200 Spaulding Tpke
Portsmouth, NH
603-436-2836

294 Ocean St
Brant Rock, MA
781-834-9301

86 Cemetary Rd
Stonington, ME
207-367-2692



SINGO & TRIVIA / GRAND BUFFET

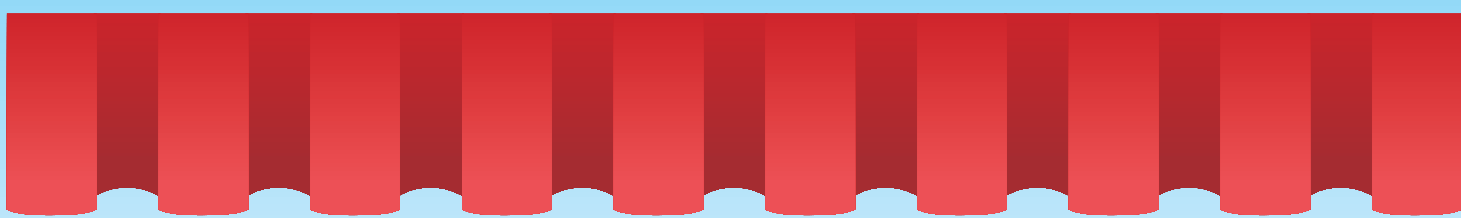

GRAND BUFFET & "SINGO"



**Bass River Room
Friday, 6:30 PM
March 22, 2024**

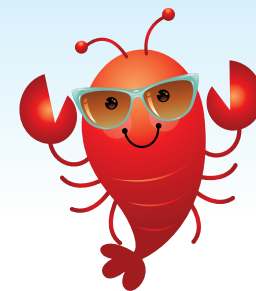

DO NOT miss your chance to win one of the cash prizes! *
DONT FORGET to bring your Pre-paid dinner tickets with you!

** - You must be present to win.*



"Singo" is Bingo in music form!

Each player has a "Singo" card with song titles on it. Steve plays the songs and if you are the first person to have all the song titles on your "singo card" you win the game and receive a prize!

Be ready to show off your knowledge of fun facts and play some trivia following Friday evening's Grand Buffet!

Prepare yourself for lots of laughter and loads of fun playing

"SINGO" & TRIVIA WITH STEVE MONTMAGNY!



Steve has been in the entertainment industry for many years hosting all types of venues on the South Shore and beyond.





2024 PROGRAM EVENTS & SEMINARS

Friday, March 22, 2024

**MLA Industry Trade Show Hours
9:00am-4:00pm**

Massachusetts Division of Marine Fisheries Public Hearing

Friday 8:30am; Room: Centerville
*Presented by: Massachusetts Division of
Marine Fisheries*

DMF is holding a public hearing to take comment on: (1) new rules affecting minimum and maximum carapace sizes, possession standards for v-notched lobsters, trap tag issuance, and escape vent sizes relevant to the January 1, 2025 implementation of Addendum XXVII to the Atlantic States Marine Fisheries Commission's Fishery Management Plan for American Lobster; (2) the use of fully-formed red weak rope with a visible "MASS LOBSTER" tracer throughout the buoy line as means of complying with both buoy line marking and breaking strength requirements; and (3) housekeeping edits to remove outdated provisions affecting DMF's black sea bass pot season and protected species regulations.

Cooking Demo

Friday 10:45am; Room: Bass River

Come see and taste what the Emerald Resort and Conference Center's Master Chef will create for you this year. You can't miss this so get there early and get ready to be dazzled. Please check the Show Program for the final menu.

A Regional Framework for Financial Compensation from Offshore Wind Impacts

Friday 11:00am; Room: Centerville
*Presented by: Kris Ohleth, Director of
Special Initiative on Offshore Wind*

Moving towards coexistence between the fishing community and offshore wind requires a variety of creative solutions. Once the options of avoiding, minimizing, and other mitigation strategies have been exhausted, a tool that can and has been applied is financial

mitigation to compensate fishermen for losses. 11 Atlantic Coast states are working together to develop a regional framework for financial compensation, which will be discussed in depth during this session.

New England Young Fishermen's Alliance

Friday 1:30pm; Room: Centerville
Presented by: Andrea Tomlinson

The New England Young Fishermen's Alliance strives to empower the next generation in our local commercial fishing industry by providing critical networking, training, and resources. Through value-based initiatives, we plan to preserve, protect, and promote the future of our small boat fishing businesses in northern New England. We currently offer an annual Deckhand to Captain training program for northern Massachusetts, NH and southern Maine commercial fishermen and women who are dedicated to becoming Owner-Operators. Our nine-month course offers intensive training in business management, budget development, public speaking, permitting and licensing, collaborative marketing, advocacy, and cooperative research opportunities. Come listen and learn more about our unique program!

B-I-N-G-O

Friday 2:00pm; Room: Barnstable III
*Presented by: The MLA and
Therese Sauvageau*

Come join us for a few rounds of B-I-N-G-O and win some prizes!

**YOU MUST BE 18 YEARS OR
OLDER TO PLAY!**

Friday 3:30pm-6:30pm MLA's Infamous Hospitality Suite Barnstable I

**Come take a break in the
Bait Shed!**

Friday 4:00pm; Room: Barnstable II
(Next to MLA Hospitality Suite)

Presented by: Brian Robbins

Need to decompress, kick back, and have a few laughs? Come hang out in the Bait Cooler with *Commercial*

Fisheries News' Brian Robbins. Brian (who considers coming down from Maine to Hyannis "going South for the winter") might share some memories from growing up in Stonington, ME or from his offshore lobstering days; he'll no doubt have stories from his travels along the New England coast for CFN; maybe he'll play a tune or two on the guitar ... who knows? The only thing for sure is, it'll be a laid-back, good time that will set you up for the evening with a big grin.

Grand Buffett Dinner & Singo & Trivia

Friday 6:30pm; Room: Bass River

Don't Forget to bring your Pre-paid dinner tickets with you!

MLA's Super Silent Auction

will be held during the Grand Buffett Dinner and will end before Singo & Trivia start. This is to benefit the MLAs Scholarship Fund. Don't forget your checkbooks!

Singo & Trivia

**Friday 7:45pm after Grand Buffett
Dinner; Room: Bass River**

Presented by: Steve Montmagny!

Prepare yourself for lots of laughter and loads of fun playing along with Steve who has been in the entertainment industry for many years hosting all types of venues on the South Shore and beyond. **Singo is bingo in music form!** Each player has a "singo" card with song titles on it. Steve plays the songs and if you are the first person to have all the song titles on your 'singo card' you win the game and receive a prize! Be ready to show off your knowledge of fun facts and play some trivia, too!

Friday 9:00pm-12:00am MLA's Infamous Hospitality Suite Barnstable I

Saturday, March 23, 2024

**MLA Industry Trade Show Hours
9:00am-4:00pm**

Make a Sea Glass Lobster Shadow Box Craft

Saturday 9:30am;
Room: Barnstable III

Presented by: Katie Finocchiaro



Come have fun with Katie as she helps you build a Sea Glass Lobster Shadow Box. Space is limited so you must sign up at the MLA Booth.

Examining the Lobster Boom and Potential Threats through Collaborative Research with the Lobster Fishery

Saturday 9:30am; Room: Centerville

Presented by: Jon Grabowski, Northeastern University, Professor, Department of Marine and Environmental Sciences, Associate Director, Marine Science Center

New England is home to some of the oldest and most iconic fisheries species in the U.S., such as the American lobster. Lobster populations and landings in coastal Maine have been consistently high over the past couple of decades, yet the fishery faces a multitude of threats currently. Several mechanisms have been proposed behind this increase in lobsters, including release from cod and other predators in coastal waters as well as bottom-up augmentation from herring bait. Yet new potential predators have emerged, such as black seabass and other potential predators of juvenile lobsters expanding into the Gulf of Maine. This talk will discuss two decades of collaborative research with the lobster industry examining hypotheses of why lobster populations boomed over the past several decades as well as the industry's observations of and potential impacts from these newcomers. Finally, we will introduce a new project partnering with the Massachusetts Lobster Association examining impacts to and the adaptive capacity of the lobster fishery.

Let's Talk about Offshore Wind, Larval Habitats and Life as a Lobsterman

Saturday 11:00am; Room: Centerville

Presented by: WHOI Sea Grant, Jennie Rheuban and Stephanie Murphy

The Sea Grant American Lobster Initiative, funded by the National Oceanic and Atmospheric Administration's National Sea Grant College Program, is addressing critical knowledge gaps about American lobster and its iconic fishery in a dynamic

and changing environment. The initiative, which began in 2019, supports both scientific research and a regional Sea Grant extension program in the Northeast U.S. Together, the research and extension components of this initiative will develop and share new knowledge and understanding with industry stakeholders and resource managers from Maine to New York. This session will feature three newly funded research projects that address issues that are directly relevant to the lobster industry. We will provide snacks and coffee to promote attendance and a more informal feel to the session. The session will be an opportunity for the research teams to share their upcoming plans for their research projects. We hope to host an open discussion about the projects to hear input from fishermen and managers on what products might be useful around each of the research topics. Projects highlighted will include: 1) the acoustic impacts of offshore wind development on lobsters, 2) stress, social disruption, trust, and adaptive capacity of the lobster industry, and 3) surface convergences as a widely undersampled microhabitat for American lobster larvae.

MA Division of Marine Fisheries & MA Environmental Police Roundtable

Saturday 1:30pm; Room: Centerville

Presented by: MA Division of Marine Fisheries and MA Environmental Police

The Massachusetts Division of Marine Fisheries (DMF) is responsible for the conservation of marine fisheries resources. This includes managing both recreational and commercial harvesting of saltwater finfish, shellfish, and crustaceans like lobster and crab. The DMF oversees policy which promotes sustainability while balancing the requirements of a complex coastal fishing industry. State officials will be on hand to present new information on lobster stock status, fishery trends, whales, and discuss other issues of concern to the industry. The Massachusetts Environmental Police protect the environment and natural resources through enforcement, education, and public outreach. The "U.S. marine resource laws exist to ensure sustainable fish populations; protect threatened marine species and the habitats they live in and to ensure these resources are around for future generations to enjoy. When people cheat and willfully violate fishery management regulations it puts those who comply with the rules at a significant disadvantage.

Friday 3:30pm-6:30pm MLA's Infamous Hospitality Suite Barnstable I

MLA Grand Banquet & MLA Awards Ceremony

Saturday 6:30pm; Room: Bass River

Don't forget to bring your Pre-paid dinner tickets with you.

Come join us for our Grand Banquet and MLA Awards Ceremony as we recognize several individuals for all their hard work and dedication to the MLA and commercial lobster industry!

We will also be giving away 3 Merry Weekend Getaways at the Emerald Resort & Conference Center! These will be drawn at the Banquet and **You must be present to win.**

Elvis is in the Building!

Immediately following the MLA Awards Presentation come join us for an evening with Mike Slater as he moves, sings, and sounds like Elvis Presley, the greatest entertainer of all time, so put on your "Blue Suede Shoes" and prepare yourself for a tribute to the "King of Rock 'n' Roll"!



Mike has been paying tribute to "The King" for over 26 years throughout the United States and Canada! Get up, dance, and sing along to the beloved songs of Elvis Presley!

Saturday 9:00pm-12:00am MLA's Infamous Hospitality Suite Barnstable I

Sunday, March 24, 2024

MLA Industry Trade Show Hours
8:00am-10:00am

Come join us as we wrap up another successful Annual Weekend & Industry Trade Show! We will be drawing all the raffles.

Don't forget to come get your **FREE Rise and Shine for the MLA's Attendees Raffle** ticket. After your coffee make your way down to the Exhibit Hall to pick up your Ticket for a chance to win cash prizes. Tickets will be given out at the MLA booth on Sunday between 8:30am & 9:30am only and drawn at 10:00am! **YOU MUST BE PRESENT TO WIN**

Let's send off our vendors with a great big show of appreciation.



LDF RAFFLE / SHADOW BOX CRAFT

Craft your stress away!



Join **KATIE FINOCCHIARO**
from
Sunshine Daydream Productions
and make a

SEA-GLASS LOBSTER SHADOW BOX!

Saturday morning at 9:30 AM
in the Barnstable III room

— Sign up at the MLA booth —



LEGAL DEFENSE FUND RAFFLE



\$1,000.00 CASH PRIZE & SCRATCH TICKETS \$255.00 VALUE



Spend
\$100.00,
get a
**LEGAL
DEFENSE
T-SHIRT**
while
supplies last!!



Ketcham Supply

2024 MLA'S ANNUAL WEEKEND SPECIALS

good through April 30, 2024

Bait Bag – 1600 ft Rolls



Victronox Knives

\$100 case of 20 serrated 3.1" blades

Proflex Rope



5% off 5 coils }
10% off 10 coils } Mix and Match

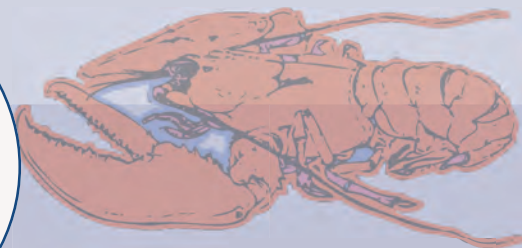

Hog Ring Pliers w/ 1lb of Rings
\$15



111 Myrtle Street
New Bedford, MA 02740
508.997.4787



www.ketchamsupply.com
info@ketchamsupply.com
@ketchamtraps



Cape Seafoods Bait Shop Kicking off the Season!

THE LARGEST BAIT VARIETY IN THE ATLANTIC NORTHEAST

In operation since 2001 and still going strong!

Trust Us for Your Fresh, Salted & Frozen Bait Needs

From (1) Carton to a Full Truck Load.

**Herring, Mackerel, Pogies, Redfish, Rockfish, Tuna, Monkfish, Sardines,
Plaice, Squid, Sea Robin, Halibut, & Silversides.**

We've got you covered!

Great News...We now buy Lobster, too!

Open Year Round (Serving clients 7 Days a Week from Mid-June To Mid-October)

Monday-Friday 5AM-3PM, Saturday 6AM-12PM & Sunday 6AM-10AM

Main Phone Line: 978.283.8522

Bait Shop Phone Line : 978.479.4642

If we don't have it... Please ask and we'll find it!





RAFFLE / ELVIS / GRAND BANQUET

MLA GRAND BANQUET & MLA AWARDS CEREMONY



**Bass River Room
Saturday Evening
6:00 PM**



DONT FORGET to bring your Pre-paid dinner tickets with you!

MERRY WEEKEND GETAWAYS at the Emerald Resort and Conference Center at Hyannis to be drawn at the Banquet. You must be present to win.

SATURDAY EVENING FOLLOWING THE MLA AWARDS BANQUET:



Elvis Presley was the greatest entertainer of all time, so put on your "Blue Suede Shoes" and prepare yourself for a tribute to the "King of Rock 'n' Roll" starring

MIKE SLATER!

Mike has been paying tribute to "The King" for over 26 years throughout the United States and Canada! Get up, dance, and sing along to *the beloved songs of Elvis Presley!*

FREE MEMBERS RAFFLE & GIFT FOR DUES PAYING MEMBERS!

ENTER TO WIN!



- All current insured members of the **MLA-NPBPC, LTD** can enter to **WIN UP TO A \$2,000 CREDIT** on your policy period 7/1/24-6/30/25. *Note: There is no cash value.*
- All membership dues & insurance premium must be paid in full in order to enter the raffle.
- All members of the MLA can also enter a separate drawing for a chance to **WIN ONE OF FIVE \$100 CASH PRIZES!**
- **FREE MEMBER GIFT!** Pick one while supplies last: MLA baseball hat, MLA Gear, a MLA pocket knife and more.
- You do not have to be present to win; we will notify you after.



MIND, BODY & VESSEL / ENGIE



ENGIE is excited to be participating in the 2024 Massachusetts Lobstermen's Annual Weekend for the first time in company history. Please come by and visit us at our booth to learn about the Neptune LNG LLC Deepwater Port Decommissioning Project. We are excited to be a part of the MLA Weekend, to being a Scholarship Fund Sponsor, and look forward to sharing and discussing our proposed decommissioning plan with you during the event.

Training for the Industrial Athlete: **MIND, BODY AND VESSEL**

Stop by the **Northeast Center for Occupational Health and Safety booth #8** during the MLAs Annual Weekend & Industry Trade Show to learn more on working safely and supporting the health and wellbeing of captains and crew members is an important part of fishing fleet sustainability. In the coming years, industry fluctuations and increasing regulation have the potential to negatively impact fishing safety and fishermen's mental and physical health. This session will focus on providing simple, practical health and safety tips to help fishermen stay as productive as possible in the 2024 fishing season. Instead of a presentation, we propose to set up six "Quick Tip" stations that fishermen can rotate through at their own pace. Each station will focus on a specific topic and will offer give-aways, info sheets and apps to help fishermen implement suggestions on their vessels.



WE DELIVER FRESH LOBSTER BAIT

INCLUDING:

HERRING

POGIES

MACKEREL

RED FISH

SKINS

BLUEFISH

CHUM

SALMON
HEADS



FRESH, SALTED, AND QUICK FROZEN BAIT

Barrel Head Bait

WE SELL SALT!

For More Information:

To Place An Order:

Mark Flight
mark@barrelheadbait.com

The Bait Line:
857-200-2129
Or Fax:
617-561-8471



NEW ENGLAND PROPELLER, INC.

Distributor of Michigan Propellers

Inboard • Outboard

Next Generation 3D Computerized Propeller Analyzer
Computerized Dynamic Balancing



Marine Fuel Tanks

Custom Fabricated & Tested to U.S.C.G Specifications
By Capeway Welding

- Marine Propeller Sales & Repairs - ***4000 Props in Stock***
 - Sierra Engine Parts for All Outboards & IOs
 - CDI Electronics • Camp & Godfrey Zincs
 - NGK Spark Plugs
 - Duramax Cutless Bearings • Spurs Line Cutters
 - PSS Dripless Shaft Seals
 - Buck Algonquin - Struts, Rudders & Stuffing Boxes
 - S/S Shafting • Drive Savers • Globe Impellers



9 Apollo Eleven Rd., Plymouth, MA 02360
Tel: 508-747-6666 800-635-9504 - neprop.com



Mandatory Electronic Vessel Trip Reporting for American Lobster Permit Holders

— Starts April 1, 2024 —

NOAA Fisheries is implementing electronic Vessel Trip Reporting (eVTR), including five additional lobster-specific data elements, for all Federal lobster permit holders using a Great Atlantic Regional Fisheries Office (GARFO) approved eVTR application. Implementation of eVTRs will begin on April 1, 2024, with the requirement that all eVTRs must be completed through the effort section of the reporting app prior to landing and submitted to GARFO within 48 hours of the conclusion of a fishing trip.

Vessel operators will be able to submit their catch reports on multiple reporting platforms (see below). We recommend lobster vessel operators download one of the apps as soon as possible so they can become familiar with entering their catch information. The current NOAA

Fish Online (FOL) iOS app does not support lobster reporting. Vessel operators who are currently submitting eVTR's through the iOS app will need to download and install the Fish Online Web app through their FOL account.

NOAA Fish Online: eVTR Web App
Bluefin Data's: VESL App
HarborLights Software: eTRIPS App

A FEW REMINDERS FOR VESSEL OPERATORS AND FEDERAL SEAFOOD DEALERS

Anyone submitting eVTR's on any of the available apps will also need to have a valid GARFO vessel operator permit. If a vessel operator does not have an operator permit, they can apply for a permit using their FishOnline account. If they need assistance with this, they can reach out to a Port Agent

(<https://www.fisheries.noaa.gov/contact/port-agents-greater-atlantic-region>) or contact our permit office by email NMFS.GAR.Permits@noaa.gov or by calling (978) 282-8438.

The reporting device is required to be on board the vessel while fishing, and all trip reports must be completed through the effort and catch portion of the eVTR before they enter port. All trips must be submitted to GARFO within 48 hours of landing.

Vessel operators are responsible for giving the dealer(s) the 14 digit eVTR number created on their reporting app.

Federal dealers are required to report that eVTR number on all federal dealer reports. The eVTR number is how GARFO matches the trip report to the corresponding dealer report.

WHERE CAN I FIND MORE INFORMATION?

For more information on vessel trip reporting, reporting requirements, reporting options, and detailed "how-to" instructions and videos by reporting app, please visit: <https://www.fisheries.noaa.gov/new-england-mid-atlantic/resources-fishing/vessel-trip-reporting-greater-atlantic-region>

GARFO Port Agents are available to assist with the Fish Online app and to answer any fisheries reporting requirement questions. We will be available in person to assist vessel operators at the Maine Fishermen's Forum and the Massachusetts Lobstermen's Association Annual Weekend in March. You can also call the vessel reporting helpdesk at 978-281-9188 with any reporting questions you may have.

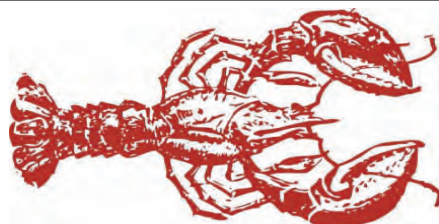

"Specializing in the sale & delivery of LOBSTER BAIT for over 30 years"

FRESH FROZEN AND SALTED BAIT AVAILABLE

**SKATES ~ HERRING ~ POGIES ~ HADDOCK ~ COD FISH ~ POLLOCK
FLAT FISH ~ FISH SKINS ~ RED FISH ~ DOG FISH HEADS ~ SALMON**



C & P BAIT
33 Wright St
New Bedford, MA 02740

Contact:
Danny Costa 508-951-9818
Carlos Pereira 508-951-9819



VINEYARD WIND

2023 Offshore Construction Update

SUCCESSFUL INSTALLATION OF FIRST TURBINE FOR VINEYARD WIND 1

In October, Vineyard Wind announced the successful installation of the first GE Haliade-X wind turbine for the Vineyard Wind 1 project, the nation's first commercial-scale offshore wind project. The completed turbine is comprised of one tower, three blades, and one nacelle. The fully assembled 13-megawatt machine represents the largest installed turbine in the Western Hemisphere and can power more than 6,000 homes and businesses in Massachusetts. The turbines being installed for Vineyard Wind 1 are spaced 1 nautical mile apart, a distance that is greater than the spacing used in any other operating wind project globally.

VINEYARD WIND 1 DELIVERS POWER TO MASSACHUSETTS GRID

As part of the initial commissioning process, at 11:52 PM on Tuesday, January 2, 2024, the first turbine delivered approximately five megawatts of power to the grid. Additional testing is planned for both on and offshore in the coming weeks. Five turbines are expected to be operating at full capacity early in 2024. (Source: [VineyardWind.com](https://www.vineyardwind.com))

2023 CABLE INSTALLATION UPDATE

In the summer of 2023, the installation of the Vineyard Wind 1 offshore export cables were completed. These cables are 35 miles in length and travel from Covell's Beach in Barnstable to the offshore substation in Lease Area OCS-A 0501.

The Vineyard Wind 1 inter-array cables have been partially installed with two strings (18 cables) completed to date. Inter-array cable installation will continue in summer 2024.

2023 FISHERIES SCIENCE UPDATE

In 2023, Vineyard Wind completed a number of scientific fisheries surveys during construction. The surveys were conducted on local fishing vessels by the University of Massachusetts, School of Marine Science & Technology.



Vineyard Wind completed two drop camera surveys (May and September), three trawl surveys (May, August, and November), a ventless trap and larval survey (May through October), and a Highly Migratory Species survey (May through September). Three years of pre-construction surveys have been completed with an additional year of surveys during construction. Post-construction surveys are planned to begin in 2025 and continue for three years to complete the Before-After-Control-Impact (BACI) analysis.

ELECTRONIC SERVICE PLATFORM (OFFSHORE SUBSTATION) 2023 CONSTRUCTION UPDATE

As of January 24, 2024:

- 47 Monopiles installed with 15 remaining for installation in 2024
- 8 completed wind turbines installed
- 22 monopiles with a transition piece
- 17 monopiles

Over 40 local fishing vessels have worked on the Vineyard Wind 1 project thus far. Wind turbine installation activities will continue through the winter with monopile installation beginning again in spring 2024.

US Coast Guard approved lighting pieces have been attached to each of the installed monopiles in Lease Area OCS-A 0501 to increase their visibility. Safety vessels will be monitoring the Wind Development Area 24/7, standing by on VHF channel 16.

VINEYARD WIND

Vineyard Wind 1 Fisheries Compensatory Mitigation Program

Vineyard Wind 1 LLC (Vineyard Wind) is constructing an 800 MW off-shore wind project located in Lease Area OCS-A-0501 approximately 15 miles south of Martha's Vineyard. The lease area (also referred to as the Wind Development Area or WDA) is approximately 63,000 acres and where 62 wind energy turbines and one electrical platform will be installed in a grid pattern spaced one nautical mile apart in a north/south/east/west direction.

Vineyard Wind has created a fisheries compensatory mitigation program with a primary objective to provide fair, equitable compensation to commercial fishermen for economic losses attributable to Vineyard Wind 1's construction, operations, and decommissioning activities.

Three escrow funds have been established to compensate affected fishermen in Massachusetts, Rhode Island, and Other States (Connecticut, New Jersey, and New York). Compensation may also be available to shoreside businesses in Massachusetts.

For commercial fishermen, the first phase of the program will be the eligibility phase, which will require commercial fishing vessel owners to qualify for compensation payments based on defined eligibility criteria. Once qualified, a commercial vessel owner may elect to participate in either an expedited claims process or an individual claims process, both of which are based on a commercial fishing vessel owner's historic revenue dependence on the WDA but require different levels of proof. Fishermen will not need to demonstrate economic impacts from Vineyard Wind 1 to qualify for the program or receive compensation payments.

The Vineyard Wind 1 Fisheries Compensatory Mitigation Program is scheduled to be launched on March 4, 2024. Information about the program, including how to apply, will be

available on the program's website: www.vw1fisheriescomp.com. Once the program launches, commercial fishermen will be able to apply to the program to establish eligibility. The program's eligibility criteria for commercial fishing vessel owners are provided on the following page.

Open house and tabling events will be hosted in March to help fishermen apply for the program. Currently scheduled events include the following:

- March 20: Superior Trawl, 55 State Street, Point Judith, Rhode Island (9 AM – 1 PM)
- March 21: New Bedford Port Authority, 123 MacArthur Drive, New Bedford, Massachusetts (9 AM – 1 PM)
- March 22: Massachusetts Lobstermen's Association Annual Meeting, 35 Scudder Ave Hyannis, Massachusetts, Emerald Resort Conference Center (9 AM – 4 PM)

The latest information about these events will be posted on www.vw1fisheriescomp.com after the program is launched.

ELIGIBILITY CRITERIA FOR COMMERCIAL FISHERMEN

- Commercial fishing vessel owners/operators homeported in Massachusetts, Rhode Island, Connecticut, New Jersey, or New York
- Valid 2023 commercial fishing permit from NOAA Fisheries
- Current government-issued vessel registration showing ownership, or a vessel lease agreement
- Documented fishing activities within the WDA in at least three of seven years during the baseline period (2016-2022). Fishing activities can be established by submitting information that includes, but is not limited to, the following:
 - Vessel Trip Reports
 - Vessel Monitoring System information

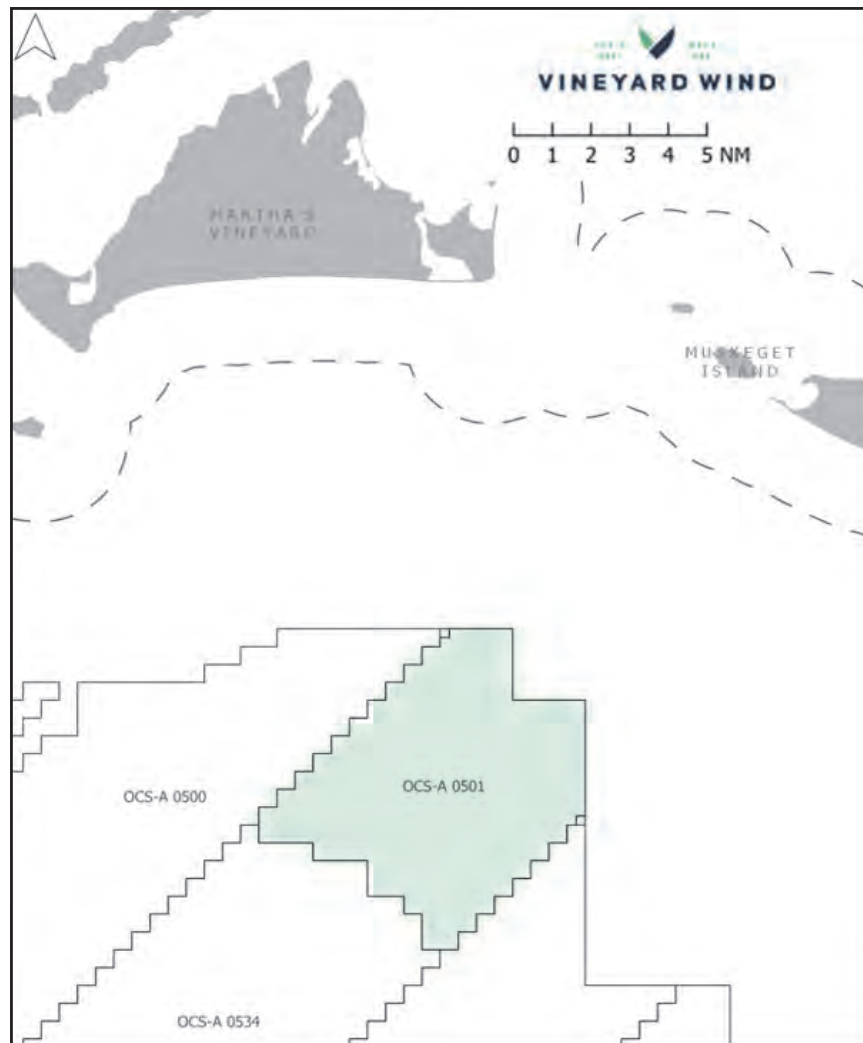

Vineyard Wind 1 WDA (green shaded area)

- AIS information
 - Fishery observer or At-Sea Monitor information
 - NOAA Cooperative Research Study Fleet information
 - Chart plotter data/images
 - Logbooks
 - Other trip-level reporting information that establishes fishing activity in the WDA
- A map of the WDA along with latitude / longitude coordinates and Loran C positions will be available for download on www.vw1fisheriescomp.com

- Documented annual revenue from fishing activities in the corresponding three years. Annual revenues can be established by submitting information that includes, but is not limited to, the following:
 - Internal Revenue Service Form 1099 and/or other tax documents that include reported income
 - Sales receipts
 - Dealer slips
 - Dealer compilation reports
 - Other income information that establishes income from fishing activities

RESEARCH FROM AMERICAN LOBSTER INITIATIVE

Exploring Larvae & Settler SURVIVAL

By Simonne Dodge, Jennie Rheuban, & Stephanie Murphy | WHOI Sea Grant
March - April 2024

Researchers work to understand the "recruitment bottleneck": why few lobsters reach adulthood in southern New England



The last two decades have seen a collapse of the lobster fishery in southern New England, with few lobsters surviving their early life stages to make it to adulthood. This research team wants to determine at what stage the lobsters are not surviving and why.

Lobster larva under a microscope. Credit: Jeremy Collie, URI



Credit: Jeremy Collie, URI

A neuston net towed behind a research team's boat

EXPLORE the PROJECT

To understand the collapse in southern New England, the team is measuring the abundance and distribution of lobster larvae and juveniles in Rhode Island waters. To collect samples of lobster larvae, the researchers are towing fine mesh neuston nets behind boats at six locations in Rhode Island. They are using two methods to sample juvenile lobsters settled on the seafloor: scuba divers using suction hoses to collect organisms from ocean sediment; and using shallow caged boxes filled with rocks mimicking lobster habitat to collect juveniles at depths beyond the reach of scuba divers.

To explore more research stories from American Lobster Initiative, visit our StoryMap collection:

<https://arcg.is/1CHT1j>



RESEARCH FROM AMERICAN LOBSTER INITIATIVE



Credit: Jeremy Collie, URI

Benthic collectors prepped for deployment



Credit: Amalia Harrington, ME Sea Grant

A postlarval lobster in the palm of a researcher's hand



Photo courtesy of the Collie Lab, URI

READ the RESULTS

From south of Cape Cod (MA) to Rhode Island Sound, the lobster population has rapidly and drastically decreased as fewer lobsters have survived to reach reproductive age – a phenomenon known as “recruitment bottleneck.” The data the team has collected will be used to test whether the recruitment bottleneck is occurring in the larval stage when lobsters are still floating higher in the water column or during the juvenile stage when lobsters are settling on the seafloor. This project is ongoing; researchers are collecting and analyzing the data.

UNDERSTAND the IMPORTANCE

A better understanding of the early life stages of the American lobster will provide insight into survival during this critical period of time. It is currently unknown why and how a recruitment bottleneck is occurring in southern New England's lobster stock.

Determining the factors impacting recruitment success and creating this bottleneck will be crucial for efforts to rebuild the lobster stock in southern New England.

Jeremy Collie - PhD PRINCIPAL INVESTIGATOR

Jeremy Collie is a professor in the Graduate School of Oceanography at the University of Rhode Island



We welcome your feedback.
Email us at lobster@whoi.edu

RESEARCHER HIGHLIGHT



Photo courtesy of Declan McCormick

Declan McCormick – University of Rhode Island

Declan is studying the state of larval and juvenile American lobster populations in southern New England as part of his master's work in Jeremy Collie's lab at the University of Rhode Island. His interest in marine science and the ocean stems from his upbringing in coastal

Maine, where he spent many hours exploring and working on the water. Lobster became an important part of his first few jobs, including work as a line cook in a seafood restaurant and helping his brother's commercial lobstering business.



THE Specialists
FROM BUOY TO TRAP

*Built the Best, Built to Last,
Built Your Way.*

PROVEN PERFORMERS! Rockbottom Runners



THEY MAKE
THE BEST
CRAB
TRAPS
TOO!!

Our precision formulation and process has been refined over the years to provide the optimum balance of strength and flexibility... – and the vise test shows it

Over **20 YEARS** of fishing;

Well over **HALF A MILLION** sold



Could you do this with any other concrete runner?



SOLID STEEL CORE - TOUGH POLYMER COATING



Over **6 YEARS** of fishing.

Over a **QUARTER MILLION** sold



OCEAN-TESTED for years... aircraft carrier decking and pilings in the marine borer intense Panama Canal Zone.



The toughest species of junglewood we've found ... and the only kind we sell.

**We are constantly listening to our customers:
Your feedback + continuous improvement
= proven reliability**

Here to serve you!

Jerry Wadsworth (207) 542-0842 jerryw@friendshiptrap.com
Jimmy Emerson (207) 483-6555 jemerson@friendshiptrap.com
Mike Wadsworth (207) 542-0841 mikew@friendshiptrap.com

Friendship Office: (800) 451-1200; (207) 354-2545
Columbia Falls Office: (800) 339-6558

Visit our website: www.friendshiptrap.com



FOR SALE:

50ft., Jersey boat 2-671 Detroit engines-twin disc transmissions-wiring needs to be finished, frame upbuild for lobstering.



30k or best offer.

For more info, call-text

Elaine 339-832-2493



The Massachusetts Lobstermen's Association (MLA) Legal Defense Fund (LDF) needs your support now more than ever. This dedicated fund is for the purpose of defending the Massachusetts commercial lobster fishermen from legal and fisheries management actions that could seriously impact our commercial lobstermen's ability to conduct their businesses and earn a living.

Currently, the MLA is actively engaged in three separate lawsuits that could have negative impacts on the commercial lobster industry and is working with our lawyers in Washington D.C. and here in the Commonwealth to fight for you and your industry.

UPDATE 2/16/2024 (Washington D.C.) Case 1:21-cv-02509-JEB - Maine Lobstermen's Association, et al. v. NMFS

Please recall our long saga fighting against NMFS' 2021 Biological Opinion has finally resulted in a win, and what a win it was! On June 16, 2023, the D.C. Circuit Court issued its ruling, unanimously finding that Judge Boasberg was wrong to uphold the Biological Opinion and ruling against NMFS on every ground raised by us. This is an excellently written opinion that not only finally understands the stakes faced by our members, but fully holds NMFS to account for its illegal attempts to destroy our industry.

While the decision in the case is now the law of the land, on November 29, 2023, we filed a Motion to recover the MLA's legal fees and costs expended in fighting against the United States Government pursuant to the Equal Access to Justice Act, which provides in pertinent part that "a court shall award to a prevailing party other than the United States fees and other expenses...incurred by that party in any civil action...., unless the court finds that the position of the United States was substantially justified

or that special circumstances make an award unjust." Here, we rightly argue that the MLA was a prevailing party, the Government's position (in the litigation and at the agency level) was not substantially justified, and consequently the MLA is entitled to recover its legal fees and costs incurred in the matter.

While the Motion is still pending before the Court, the Government asked us to stay that Motion so we could try to negotiate a settlement. We are actively negotiating with the Government and expect to have more news in the next couple months.

UPDATE 02/16/2024 (Washington D.C.) Case 1:18-cv-00112-JEB - CENTER FOR BIOLOGICAL DIVERSITY et al v. ROSS et al.

This case is finally coming to a close, as Judge Boasberg granted ours and the government's motion to dismiss the NGOs case. He also vacated most of his old opinions, leaving in place some minor ones that do not affect us going forward.

We have no doubt that the NGOs will bring a similar lawsuit after 2028 when the next Biological Opinion comes out, so having this case dismissed and the old rulings vacated sets us up well for continued success.

Overall, we are very pleased to have this case finished and for the NGOs' attempts to force NMFS to regulate our industry with even more draconian rules to have been put firmly to bed.

UPDATE 2/16/2024 (District of Massachusetts Case) Case No. 1:24-cv-10332-WGY; MLA v. NMFS et al

Last year NMFS illegally extended the 2022 Wedge Closure to close the Wedge from February through April 2023. We challenged this decision in Court and the Court agreed we were right on the law, but ultimately decided not to stop it because we could not show irreparable harm.

NMFS is now at it again, attempting to convert its illegal 2023 Wedge

Legal Defense Fund Updates

Closure into a Permanent Final Rule. We submitted a robust comment to the proposed final regulation explaining to NMFS why its proposed final rule is illegal.

Despite this, NMFS proceeded with the illegal wedge closure, ignoring Congress' clear mandate not to further regulate the lobster industry and relying on the same illegal science that the D.C. Circuit struck down.

We moved for a preliminary injunction to stop this before it could go into effect this season. NMFS has until February 23, 2024 to file its opposition brief. The Court will set a hearing for the following week.

MS has attempted to intervene in the matter, and we intend to strongly oppose this and make the Court aware of MS's long history of adversarial actions.

The commercial lobstermen's businesses are at stake as well as the thousands of jobs and shore side businesses that depend upon the continued success of the commercial lobster industry. The commercial lobstermen in Massachusetts are NOT to the problem and have done everything asked of them by National Marine Fisheries Service and have been working under the strictest conservation rules for the right whales anywhere in the world since 2014. Yet here we are, still fighting these lawsuits to keep the Massachusetts commercial lobstermen fishing.

The Massachusetts Lobstermen's Association has been actively involved in these lawsuits since 2018 and we need your generous support today to continue our fight to keep the commercial lobstermen fishing. As we all know, any legal action costs lots of money and over the last 5 years the Massachusetts Lobstermen's Association Legal Defense Fund has spent over \$300,000 fighting these legal battles. These are real threats to the historic and iconic commercial lobster industry, and we are doing everything to keep Mas-

sachusetts commercial lobstermen fishing.

WHERE TO MAKE DONATIONS

Any contribution to the Legal Defense Fund is greatly appreciated.

Donate by mail:

MLA LDF
8 Otis Place, Scituate, MA 02066

Donate online:

www.lobstermen.com

- In the Members section, select Dues/Donate.

Thank you for your continued support!



DONATE TODAY!

to the Massachusetts Lobstermen's Association

LEGAL DEFENSE FUND

MAR 2024 SUPPORTERS

David Cataldo
John Clay
Robert Coyne
Eric Lorentzen
James Moleti
Damian Parkington
Therese Sauvageau
Peter Wallace



Donate to the MLA Legal Defense Fund to
“Band the Bite” TODAY!

Help us fill the lobster crate and help relieve
the “PINCH” of defending commercial lobstermen!

Let's fill the lobster crate TODAY!

Every \$25 dollars donated puts another lobster in the lobster crate!!

There are several ways to make a donation

MLA website: www.lobstermen.com Legal Defense Fund Donation

Paypal: Legal Defense Fund Donation

Mail or drop off a check:

MLA, 8 Otis Place, Scituate, MA 02066

Call the MLA : 781-545-6984 xt2

Use your camera on your phone to Scan the QR Code

***THANK YOU for YOUR
CONTINUED SUPPORT!***



HERCULES
SLR (US) Inc.
MARINE • FISHING GEAR • SAFETY

44 South Street, New Bedford, MA 02740
Phone: 508-993-0010 Fax: 508-993-9005
Securing - Lifting - Rigging
82 MacArthur Dr. New Bedford, MA 02740
Phone: 508-992-9519 Fax: 508-992-9419



www.Hercules-SLR-US.com

JohnReardon@Hercules-SLR-US.com

USCG Safety Inspection Station #327

Commercial Fishing-Marine Safety-Rigging

- ❖ Marine Hardware
- ❖ Cotesi - Netting, Leaded/Sink Rope
- ❖ Stormline & Climate Technical-Foul Weather Gear
- ❖ Buoys & Floats
- ❖ Lobster Bands
- ❖ PFD's, Vests, Float Coats
- ❖ Fish Totes
- ❖ Insulated Tubs
- ❖ Cordage & Twine
- ❖ Mooring Equipment
- ❖ Boarding Ladders
- ❖ Polysteel Rope- Esterpro Sinking, Hydropro
- ❖ Leadline
- ❖ Wire Rope - FC Galv, IWRC, Dyform
- ❖ HiFlyers 12', 14' & 15' XHD
- ❖ Golf & Batting Cage Netting



Inflatable PFD's



Life Raft Sales

- ❖ Revere
 - ❖ Elliot
 - ❖ Survitec
 - ❖ Switlik
- All brands accepted for service



ACR Electronics
Sales & Service
for your E.P.I.R.B.



Fenders & Buoys-All Colors



Boots from
Honeywell Safety

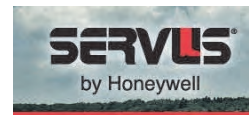

On-Board Vessel Inspections & Safety Drills

Call our USCG Certified Drill Conductors:

Rodney Avila 508-889-0401

Ted Williams 508-264-5779



Imperial
Survival Suits
Sales & Annual
Inspections
Done in house

MASSACHUSETTS LOBSTERMEN'S ASSOCIATION, INC. 2024 EDUCATIONAL GRANT APPLICATION

This application should contain accurate and detailed information and be accompanied by a copy of your official high school transcript that is signed and sealed.

Name: _____

Home Address _____

City/Town: _____ State _____ Zip _____

Father, Mother and/or Guardian's Name: _____

Occupation _____

Are they a current member of the Massachusetts Lobstermen's Association? [] Yes [] No

Are both parents living? [] Yes [] No

Number and ages of siblings living at home: _____

Do you have anyone financially dependent upon you? [] Yes [] No

If yes, please explain: _____

How much financial aid is expected in your first year of college/trade school: _____

Name of High School and year of graduation: _____

Name of college or trade school you expect to enter: _____

Have you been accepted: _____ What is your anticipated tuition: _____

Have you received any other scholarships - If yes, state amount(s): _____

What business or profession do you expect to prepare for: _____

What extra-curricular activities have you participated in: _____

REFERENCES: **Please enclose any letters of recommendation** and **at least two** from the following choices: School Principal, Guidance Counselor, Instructor in your major, Pastor or Minister.

Please write a short paragraph explaining why you are interested in your field of endeavor:

Educational grants are awarded at the discretion of the committee and all decisions are final.

SIGNATURE: _____ DATE: _____

-- THIS APPLICATION MUST BE RETURNED BY APRIL 15, 2024 --

Mail or drop off applications to:
Massachusetts Lobstermen's Association Scholarship Committee, 8 Otis Place, Scituate, MA 02066

MLA Classifieds

Classified ads are a free benefit to MLA Members and Non-members are a flat \$25.00. Ads run for 5 months & will be automatically deleted unless you call the MLA office to renew. **781-545-6984** or email ads to: tracey.abboud@lobstermen.com
*All ads are subject to review prior to placement

AD#1 (9/23) **FOR SALE** – Trap Trailer 6x12 can hold approx. 50-3 footers. Good shape. \$1,200.00 Call Ben 978-578-8882

AD#2 (10/23) **FOR SALE** – Hydraulic Components, parts, and service. Pumps, Motors, Valves and Accessories. Hydraulic Hoses are made while you wait. Great Prices–Same day service (in many cases)-Wide selection of in-stock items. Rebuilt items are occasionally available. ROSE MARINE, Gloucester, MA 877-283-3334

AD#3 (10/23) **FOR SALE** – KC Trap & Mesh–Traps-Heads-Finished Kits. Call for more information. 774-280-6638

AD#4 (10/23) **FOR SALE** – 1981 50 Ft., Jersey Boat- Twin disc 507- Detroit 671- Needs wiring & electronics. BRO \$25,000.00 Call for more info-781-834-6733

AD#5 (10/23) **FOR SALE** – Bruce Atkinson Novi 38ft 1984. Rebuilt John Deere 6081 375 hp/1500 hrs. by Downeast Diesel. 2 steering stations, 14" ss pot hauler, ss davit, 295 Furuno color machine & tons more. Very well-maintained boat. Available in Gloucester. Reach out with ANY question. Chris 781-424-6946

AD#6 (10/23) **FOR SALE** – In Boston. 60 new yellow cavatorta wire 43.5 x 22.5 x15 lobster traps. Kitchen haul, double parlor hand knit head in rear, 10 gauges ends, bridges & front corner braces. 12-gauge body, side brace, skid plate & side chaffing pieces. Has plastic coated steel runners, plastic corners & plastic runner bumpers. These are quality made traps that you will absolutely love to haul! \$182 each. Call Ed 617-680 -4096

AD#7 (12/23) **FOR SALE** – 500+ lobster traps w/line & buoys 3ft. \$20.00- 4ft.\$35.00, located in Scituate. Can use yard where the traps are stored to get traps ready for use no charge for compressed air or electricity. Call 978-815-1734

AD#8 (10/23) **FOR SALE** – Turnkey Outer Cape Lobster Business: 1981 31ft. BHM Volvo 63P–370 HP, 2 1/2:1Twin Disc, spare wheels, many spare engine parts. OC State permit w/270 tags+ 10%, many endorsements, 400+ traps, ground lines, end lines, flags, Go-Deeps, 200 totes, lids,+ trap building tools & equipment. Boat also setup for Dogfish & Mackerel w/ all gear, 8x16 traot trailer, 5'x7' walk in bait cooler, 6000#mooring in Chatham Harbor, fiberglass skiff with 10HP Suzuki 4 stroke & trailer. \$200k Or BRO Steve 978-257-1062

AD#9 (10/23) **FOR SALE** – 31 ft., BHM Lobster boat. 300 hp- John Deere, 2-VHF radios, chart plotter, Furuno fish finder, built in live tank, radar, 3 swivel rod holders. \$65,000.00 Call 508-280-3038

AD#10 (1/24) **FOR SALE** – Wooden conch pots, wood repair stock made to order, call 774-201-0712

AD#11 (1/24) **FOR SALE** – 1980 Bob Rich 40 wooden lobster boat. 471 Detroit diesel, twin disc gear, hydro-slave pot hauler w/diverter valve for other fisheries. Two 75-gal fuel tanks (fiberglass) under deck, full cabin, GPS, Furuno

depth sounder, VHF radio, MA coastal Area 1 lobster permit, 800 trap. Federal Area 1 lobster permit w/endorsements (ground-fish/dogfish) 800 pot limit. 140 wire lobster traps, some never used (brand new) 60-70 buoy's, extra ropes, safety equipment, sea anchor, 12 fiberglass skiff misc; lobster related equipment, spare propeller (never used) trap related repair equipment. \$65,000. firm. Bill @ 781-834-7418

AD#12 (12/23) **FOR SALE** – 33 ft. lobster boat 1987 Novi/Scott 150 Ford engine. 600 trap N.H. lobster license 100+ traps, dingy, trap trailer, ropes & buoys. Boat has been out of the water for 3-years. Also, a mooring at Pierce Island. \$54,900.00 Call Douglas @ 603-566-3654

AD#13 (12/23) **FOR SALE** – 22' Sisu Lobster Boat W/150 HP Evinrude OB needs work. Has 12' Hydraulic hauler. Runs off Honda Hydraulics. Power Pack needs work. Comes W/ bunk trailer. Asking \$8000. or B.O. Call Robert@ 5:00 p.m. 617-846-3714 or 617-650-3842

AD#14 (10/23) **FOR SALE** – Federal Area 1 Permit: Offers over \$35,000 will be considered. lhsea@aol.com 781-639-0001

AD#15 (10/23) **FOR SALE** – Airseep- air-cleaner 5" \$100.00 Joel @781-581-0324 or E-mail joel.w.marie@gmail.com

AD#16 (10/23) **FOR SALE** – 5" Superior hauling block-Aluminum construction with stainless sheave \$250. Joel @ 781-581- 0324 or E-mail joel.w.marie@gmail.com

AD#17 (10/23) **FOR SALE** – Spare new stainless sheave for 5" Superior block-\$150. Call Joel at 781-581-0324-E-mail joel.w.marie@gmail.com

AD#18 (1/24) **FOR SALE** – 1990 42 ft PEI lobster boat in excellent condition. Cummins 8.3L -6 CTA w/ ZF gear. 1700 hours on each. Electronics, safety gear, very well equipped.700 Brooks Trap Mill custom traps. 3/8 Everson ground line, & whale safe compliant end lines, Hi flyers & tide balls. State & federal licenses. As of June 1st, all gear in the water. Baited, tagged & fishing. Buy today & fish tomorrow Complete package \$290,000. Will separate Boat \$210,000, traps \$75,000. state license \$30,000. & fed license \$40,000. Call 978-745-6182, leave message. Serious inquiries only – Pictures available

AD#19 (10/23) **FOR SALE** – In Boston. 60 new black cavatorta wire 43.5 x 22.5 x 15 lobster traps. Parlor haul, double parlor, shrimp mesh,10-gauge ends, bridges & front corner braces. 12-gauge body, side brace, kitchen brace, skid plate & side chaffing pieces. Has plastic coated steel runners, plastic corners & plastic runner bumpers. These are quality made traps that you will absolutely love to haul! \$180 each. Call Ed 617-680-4096

AD#20 (10/23) **REDUCED-FOR SALE** – Complete lobster business. Area 1 MA State license 800 trap allocation with long history. Dog & shellfish endorsement. 1987 Gummond 31' w/12' beam enclosed cabin w/ "bus" heater 12kts cruise w/20+top end Cummings re-manufactured "Diamond" version 370 HP

with 3500 hours. 300+ traps w/ ropes & buoys. 14ft tender w/ 3yr old Suzuki 4s 15 hp w/electric start. GPS/bottom sounder, life jackets, fish totes, etc. Would like to sell it as a package but will accept separate offers on boat, license & fishing gear. \$70,000. OBRO Call Bob- 508-224-1664 or e-mail @ roalward@comcast.net Pictures available.

AD#21 (9/23) **FOR SALE** – 1 24X24 Freeman Hatch. Used. In good condition. \$500.00 1 36 foot shear \$300.00 1 4' by 8' trailer \$200.00 Call Ted 401-842-8165.

AD#22 (10/23) **FOR SALE** – Lobster business peripherals: OCLMA permit for 645 tags, dingy, tank, freezer, mixture of wood & wire traps in excellent condition, totes, etc. Serious inquiries only: 774-313-6287 or joneSeven@aol.com

AD#23 (10/23) **FOR SALE** – Hook gear 5 totes 125 hooks per tote all brand new.5 totes used gear. Brand new Danforth anchor included. \$1000. Call 781-831-1609

AD#24 (1/24) **FOR SALE** – Lobster Business- 28.2ft boat, built in 1976 engine cat 3208, 265HP trans 2.1 twin disk fiberglass JC hull. Area 1 Coastal lobster permit 800 trap allocation, 700 3ft lobster traps with rope and buoys. 80,000. Joe at 978-239-5927

AD#25 (1/24)**FOR SALE – Price Reduction** -36.5' Wayne Beal Lobster Boat. 3208 CAT 375 hp Turbo w/7600hrs. Motor was completely overhauled prior to 2022 fishing season. Furuno chart plotter, depth, radar & radio. 2nd Simrad below. Switlik life raft, survival suits & Epirb. Small galley w/sink, insulated icebox & 2500-watt inverter for coffee. 4 bunks w/mattresses. Working head. Pacer pump & separate wash-down pump. Redundant spare equipment (all new in box), Inc. Pacer pump w/hydraulic hoses, belts, starter motor. 2 alternators. windshield wiper arms & motors, bilge pumps, deck hoses, etc. The boat is clean & in excellent, fishable condition. \$190,000.00 Traps & Permits available. Ben 978-578-8882

AD#26 (11/23) **FOR SALE** – 2-506 twin disc transmissions 4k for both- priced to sell. Call/text Elaine 339-832-2493

AD#27 (1/24) **FOR SALE** – American Lobster Federal Permit- Area 2-420 trap allocation. \$35,000.00 Call 631-903-2063

AD#28 (9/23) **FOR SALE** – Gill Nets (10 assorted, some new or recent rehangs (Hercules). Gill net reel, 48" diameter, 42" width. Holds average 4 + panels (1200'). Excellent condition, chain drive, full hydraulics. Complete tub trawl system equipped with 10" hydraulic hauler for retrieving Tub Trawls mounted on net reel. "Jamestown" / Chatham gravity baiter (3-bushel size). Four totes set up with stainless magazine hook storage 125 hooks (500 total), 300 additional hooks storage system (four totes), fast and simple to use. Over half mile, set up for Cod, blue fish, Spiny Dog fish, or what have you. Loads of extra clips, gangions, boxes of Brand-new Mustad E-Z Baiter hooks. Two survival suits (like new 3 years

old). Still mounted on boat, can demonstrate until mid-September. Located in Freeport, Long Island, New York. Hoping to get \$1500.00 – 2000.00. We can talk. Call or text Captain Rich Hunter. 347-836-5382, I will most likely get back to you after 6:00 pm that evening. Be glad to answer any questions.

AD#29(2/24) **FOR SALE** – Slide in insulated refrigerated body for a pickup truck. Ted 843-267-3473 or mrfish@mrfish.com

AD#30 (10/23) **FOR SALE** – 50ft., Jersey boat 2-671 Detroit engines-twin disc transmissions-wiring needs to be finished, frame upbuild for lobstering. 30k or best offer. For more info, call-text Elaine 339-832-2493

AD#31(12/23) **FOR SALE** – Area 1 Coastal lobster permit \$25,000.00 Call Pete @ 508-364-5980

AD32 (1/24) **FOR SALE** – Wooden conch pots, wood repair stock made to order, call- 774-201-0712

AD#34 (12/23) **FOR SALE** – Lobster traps & rope Approx. 150 – 48" & about 25 – 36" lobster traps for sale some free. Most need some work. Some are just cages. \$20 for the best...free for the rest. Extra doors, new headsets, runners, window weights, 20 pot trawls of 7/16" ground lines, & miscellaneous also available. Prefer the traps go in minimum lots of 50 traps. Will crush & scrap what is left. Must clean out-Pickup in Hull -Email jnak388@hotmail.com for more info.

AD#35 (1/24) **FOR SALE** – 200 45" Friendship lobster traps 8-6 years old \$25.00 each Call 508-510-7792

AD#36 (1/24) **FOR SALE** – 32" – 4 blade Dyna Quad Prop-2 1/2" bore, left hand \$2,500.00 Call 508-510-7792

AD#37 (1/24) **FOR SALE** – 1-34" Hytorg prop 2 1/2" bore, left hand \$1,000.00 Call 508-510-7792

AD#38 (8/23) **FOR SALE** – 1985 25ft., Privateer Lobster Boat. Fresh water cooled Mercruiser v8 engine-260 hp. Runs great-spare re-built engine. A IO spare re-built prop-hydraulics steering new in box. Re-built 4-wheel trailer. Gantry system to lift boats off trailer. Garmen chart plotter GPS Map Garmen depth sounder-fish finder. VHF radio. The engine has stainless steel heat exchanger. Stainless steel exhaust risers. 50-30"lobster pots ready to fish. 100 spare buoys 2- coils rope-440 gal refrigerator lobster tank-platform scale for weighing. Ice chipper. 3- 28" scallop drags-system is ready to fish. X-actic polar box 48x44x36- 5-boat stands. 8' Pram- Many other items- Call between 4-7 p.m. \$20,000.00 508-979-0568

AD#40 (12/23) **FOR SALE** – Traps- 50 3ft yellow shrimp mesh brand new, ergos, composite runners skid plate, all corners reinforced, stainless bait spike, seal proof door latches,4 corner bumpers & plastic edging all around extra clips built to last \$ 120 each. 50 -3 ft shrimp- Call 978-774-4074

CAT[®] Marine Power – C18

Available for new boat installations and repowers.



Ask us about our Customer Value Agreements (CVA)

C18 RATINGS

470/600@1800rpm A Rating

670/715@1800-2100rpm B/C rating

803@2100rpm D Rating

1015/1150@2300rpm - T4 Exempt ratings for light commercial

For Marine Engine Sales, contact Nick Fawle, Marine Market Manager.
603-484-5248 Nick_Fawle@miltoncat.com

AUTHORIZED MARINE DEALERS

Billings Diesel & Marine Service
Stonington, ME

Dennis' Welding & Marine
Beals, ME

Front Street Shipyard
Belfast, ME

Lyman Morse at Wafarer Marine Corporation
Camden, ME

Journey's End
Rockland, ME

Fairhaven Shipyard & Marina, Inc.
Fairhaven, MA

Guy Crudele Repair
Gloucester, MA

Sacchetti Marine and Industrial, LLC
Plymouth, MA

Windward Power Systems
Fairhaven, MA

DePaul Diesel Services, Inc.
Portsmouth, RI

Hinckley Yacht Service
Portsmouth, RI

Rhode Island Engine Company, Inc.
Narragansett, RI

Milton 

miltoncat.com

Massachusetts Lobstermen's Association
8 Otis Place
Scituate, MA 02066

PRSR STD
U.S. POSTAGE
PAID
Permit 137
New England Newspapers, Inc.



Stock and Custom-Built Traps
Lobster and Specialty Traps
Aquaculture Supplies
Huge Inventory of Commercial
Fishing Supplies
Four Locations in Maine



BROOKSTRAPMILL.COM
(800) 426-4526