



MASSACHUSETTS LOBSTERMEN'S ASSOCIATION

A LEADING Commercial Fishing Industry Association in New England



JOIN TODAY and show your support

DECEMBER 2023 NEWSPAPER • WWW.LOBSTERMEN.COM

On Demand Gear Continues to Gain Momentum

MLAs Director, Beth Casoni and Secretary-Treasurer, Dave Casoni, recently attended the 2023 Annual Ropeless Consortium meeting held in Halifax, Nova Scotia. The meeting was attended by over 200 people from around the world all looking to learn more about what is happening in the on-demand gear realm. There were also 8-10 engineers of the on-demand gear on hand to present their updates on their gear.

The concept of on demand gear has been kicked around for several years now and the hurdles they still are facing are as real as they were when they started. The gear still does not talk to each other making identification of the gear impossible and the lack of mobile gear involvement is clear that this on demand gear is still in its embryonic stage.

To this day, the cost of on-demand gear has not come down as some developers boasted in the beginning. One until 8 years ago was \$3300 and today it is \$8000. This disclosure blew holes in the notion that the cost would go down as demand increased. Clearly demand has not increased.

While, the MLA Director and Secretary-Treasurer was there, they were able to talk with commercial lobstermen from Australia who clarified a lot of questions. The biggest questions they clarified was that WHY, the individual commercial lobstermen in Australia were using the on-demand gear which was, gear loss. Not whales, not theft, and not because they liked it. The bottom-line is that these individuals were losing tens of thousands

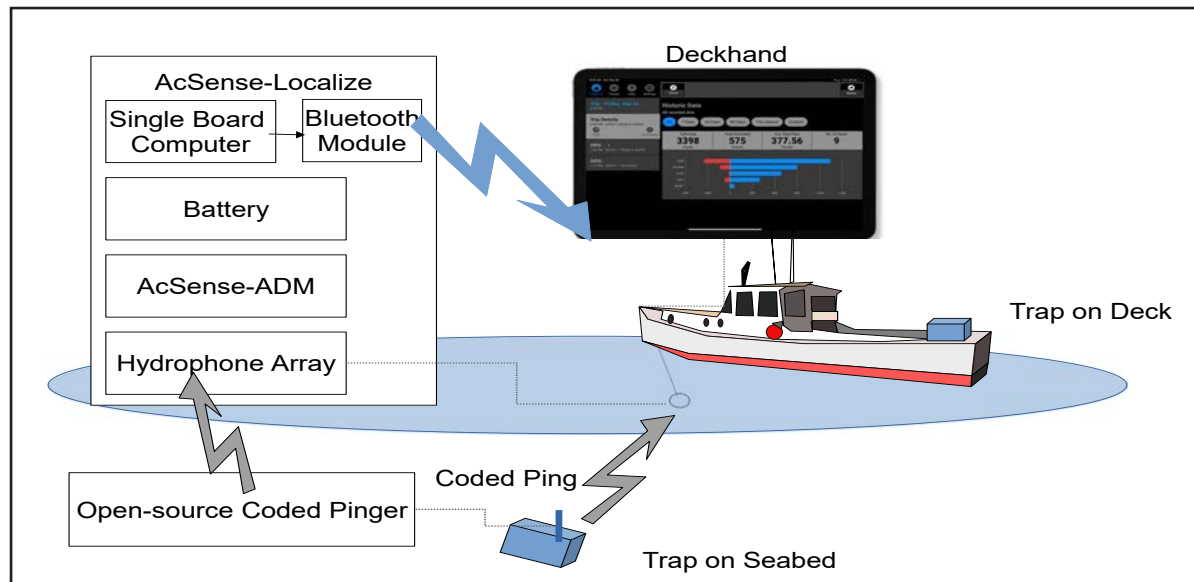

of dollars in gear, and this was a solution.

The presentations that were given covered updates on the on-demand gear testing and all the reasons why on-demand gear is the “ONLY” solution on the table to save the North Atlantic right whale. The most surreal comment was from one of the environmental groups that stated, “We still have groundlines in the water” leaving this open ended and even more altruistic. Unrealistic is an understatement.

While these developers and environmental groups have their dreams of grandeur, the commercial lobstermen are watching and waiting with bated breath as this conversation swirls around them all the while they are at the center of this storm. The wait is over, as the Lobster Foundation of Massachusetts (LFoM)

was recently awarded a National Fish and Wildlife Foundation grant to develop a pinger to geo-locate the traps on the bottom that will be grappled up during the closed season.

While this concept is not supported by much of the fleet, the commercial lobstermen in Southern New England are truly losing their businesses due to the 5,500 square mile seasonal closure that coincides with their fishing season. The MLA and LFoM must do something the develop a cost-effective solution and not leave it to the \$3000-\$8000 per unit engineers. We are hopeful these pingers will cost about \$300-\$500 (TBD) when completed.

For more info on how to get involved in the “Grappling with Technology” project please email info@lobsterfoundationofma.org



Cape Seafoods Bait Shop Kicking off the Season!

THE LARGEST BAIT VARIETY IN THE ATLANTIC NORTHEAST

In operation since 2001 and still going strong!

Trust Us for Your Fresh, Salted & Frozen Bait Needs

From (1) Carton to a Full Truck Load.

**Herring, Mackerel, Pogies, Redfish, Rockfish, Tuna, Monkfish, Sardines,
Plaice, Squid, Sea Robin, Halibut, & Silversides.**

We've got you covered!

Great News...We now buy Lobster, too!

Open Year Round (Serving clients 7 Days a Week from Mid-June To Mid-October)

Monday-Friday 5AM-3PM, Saturday 6AM-12PM & Sunday 6AM-10AM

Main Phone Line: 978.283.8522

Bait Shop Phone Line : 978.479.4642

If we don't have it... Please ask and we'll find it!

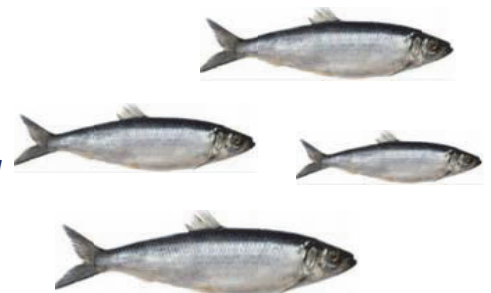

MLA Sponsors

The following companies are proud supporting MLA members. We encourage our members to patronize them. If your company is not listed and you would like it to be, contact Tracey Abboud at 781-545-6984, ext. 2

**ALIVE & KICKING
LOBSTER**
LOUIS MASTRANGELO
CAMBRIDGE, MA
617.876.0451

BOSTON LOBSTER FEAST
JEFF HAZELL
ORLANDO, FL
407.832.7322

BOSTON SWORD & TUNA
STEPHEN SCOLA
BOSTON, MA
617.946.9850

BROOKS TRAP MILL
STEPHEN BROOKS
THOMASTON, ME
207.354.8763
stephen@brookstrapmill.com

**CAPE ANN MARINE
SALES & SERVICE**
978.283.0806
capeannmarina.com

**CAPE SEAFOODS
BAIT DEALER**
GERRY O'NEIL
GLOUCESTER, MA
978.479.4642

**CAPE FISHERMEN
SUPPLY**
DAVE LIBBY
CHATHAM, MA
508.945.3501

CAPE TIP SEAFOODS
CHRIS KING
PROVINCETOWN/ORLEANS
508.487.0259 | 508.225.7221

**CAPTAIN MARDEN'S
SEAFOODS**
KIM MARDEN
WELLESLEY, MA
781.329.7007 | 781.329.0792
captainmardens.com

CHERRY ST. FISH MARKET
DARRYL PARKER
DANVERS, MA
978.777.3449

**CHRIS ELECTRONICS
CORP.**
FAIRHAVEN, MA
508.994.8257

EAST COAST SEAFOOD
SPIROS TOURKAKIS
LYNN, MA
781.593.1737

ECKLAND & BLANDO
SAM BLATCHLEY
BOSTON, MA 02110
617.217.6936
www.ecklandblando.com

ELECTRA-DYNE CO INC.
JUDY MACCAFERRI
PLYMOUTH, MA
508.746.3270

FARM CREDIT EAST
MIDDLEBORO, MA
508.946.4455

FISHER AIR FASTENERS
ED & CHRIS FISHER
PEMBROKE, MA
781.826.2522

FISHERMEN SERVICES
DONNA CHEPREN
781.545.5073 Ext. 16
fishermenservices.com

**FLEET PROPELLER
SERVICE**
MIKE VALM
FAIRHAVEN, MA
508.979.8000

FRIENDSHIP TRAP CO.
FRIENDSHIP, ME
800.451.1200

HAMILTON MARINE INC.
56 US ROUTE 1 BYPASS
KITTERY, ME 03904
207.439.1133
hamiltonmarine.com

HARBOR FUELS
info@harborfuels.com
617.720.3835

HERCULES
JOHN REARDON
NEW BEDFORD, MA
508.993.0010

JAMES HOOK & CO.
ED HOOK JR.
BOSTON, MA
617.423.5500

KETCHAM TRAPS
HEATHER KETCHAM
NEW BEDFORD, MA
508.997.4787

KINGFISHER TRAP
CARL HOWARD
DENNIS, MA
508.385.5968

KING LOBSTERS
D.J. KING
BRANFORD, CT
203.488.6926

KING MARINE LLC
CAPT. GEORDIE KING
MARINE SURVEYOR
207.337.8706
kinggeordie@comcast.net

LOBSTER CRUISES
PAUL QUINTAL
PLYMOUTH, MA
508.746.5342

**LOBSTER TRAP
FISH MARKET**
MONUMET BEACH, MA
508.759.6400
lobstertrap.com

LOBSTER TRAP CO.
MAC HAY
BOURNE, MA
508.214.3290 Ext. 101
lobstertrap.com

**MARINE HYDRAULIC
ENGINEERING**
ROBERT CROWE
ROCKLAND, ME
207.594.9525 | 800.747.7550

**MILTON CAT
POWER SYSTEMS**
MILFORD, MA
508.207.8542

**MORTILLARO LOBSTER,
INC.**
VINCE MORTILLARO
GLOUCESTER, MA
798.281.0959

NAPA-CAPE COD
BILL DRINAN
FALMOUTH, MA
508-457-1734

**NAVROC MARINE
ELECTRONICS**
JASON PHILBROOK
ROCKLAND, ME
207.596.7803

**N.E. MARINE &
INDUSTRIAL INC.**
MIKE RICHARDSON (NH)
603.436.2836 | 781.834.9301
info@newenglandmarine.com

**NEW ENGLAND
PROPELLER**
DOUG PECK
PLYMOUTH, MA
800.635.9504
neprop@aol.com

**NORTH ATLANTIC
POWER-TWIN DISC**
SAM PROFIO
EXETER, NH
sprofio@glpower.com
603.418.0470

RFP LOBSTER BAIT
DICK PERENTZ
774.248.0292

**RIVERDALE MILLS
CORPORATION**
NORTHBRIDGE MA
508.234.8715
riverdale.com

ROSES MARINE
GLOUCESTER, MA
877.283.3334
rosesmarine.com

SEA CLIFF LOBSTER
MANOMET, MA
508.224.5700

**SPURS MARINE
MANUFACTURING**
PABLO SOSA
FORT LAUDERDALE, FL
800.824.5372

SUPERIOR LOBSTER
MARSHFIELD-SANDWICH
774.773.5048
www.superiorlobster.com

**TWO COUSINS
FISH MARKET**
BRIAN O'DONOHUE
FREEPORT, NY
516.379.5065

**WINDWARD POWER
SYSTEMS**
FAIRHAVEN, MA
774.992.0059
windwardpower.com

WOOD'S SEAFOOD
JAY KIMBALL
PLYMOUTH, MA
508.746.0261
www.woodseafood.com



IN MEMORIAL



Arthur "Sonny" Mallowes

It is with heavy heart that we must tell you that one of the MLAs earliest member, Arthur "Sonny" Mallowes 95, passed away at home, surrounded by family and his 4-legged buddies. He was the genuine article; a true Chathamite. Born at Cape Cod Hospital, son of Edward and Cecilia Mabel Mallowes, he lived a solidly good and simple life. He entered the Coast Guard after High School and was stationed on the Handkerchief Shoal Lightship, serving his country on the water and then went on to serve his family as a fisherman. Sonny met his future wife, Thelma Morrell, on a blind date arranged by her cousin. They married 6 months later. They are both survived by two sons, Edward and David Mallowes, their wives, and families. He was particularly proud of son Edward being the Captain of a New Bedford scalloper and of David being a lobsterman. He was a lifelong Chatham fisherman, well into his eighties. If you knew Sonny, you knew he had nine lives. Two of them involved falling overboard, once in his youth from the Lightship, and once in his senior years while quahogging locally.

A man of his generation, he was rooted in verbal relay of information, the sanctity of books and the handwritten word. He spoke easily to strangers, loved his family, treasured his friends, and adored his dogs. Best known for his storytelling and expansive knowledge of town history, he shared generously to all who would listen. We believe his physical body just ran out of space; it was so full of so many stories. In more recent years, he'd be found sitting outside in a chair in his neighborhood with a dog or two at his side as he busied himself with tasks that supported Dave's lobstering business. He loved his neighbors, and they loved him. He'll be remembered for his kindness, his humor and humility.

May he sail on calms seas with fare winds!



THE *Specialists*
FROM BUOY TO TRAP

**Built the Best, Built to Last,
Built Your Way.**

PROVEN PERFORMERS! Rockbottom Runners



Our precision formulation and process has been refined over the years to provide the optimum balance of strength and flexibility... – and the wise test shows it

Over **20 YEARS**
of fishing;

Well over **HALF
A MILLION** sold



*Could you do this with
any other concrete runner?*



Over **6 YEARS**
of fishing.

Over a **QUARTER
MILLION** sold



OCEAN-TESTED for years...
aircraft carrier decking and
pilings in the marine borer
intense Panama
Canal Zone.

*The toughest species
of junglewood we've found
... and the only kind we sell.*

**We are constantly listening to our customers:
Your feedback + continuous improvement
= proven reliability**

Here to serve you!

Jerry Wadsworth (207) 542-0842 jerryw@friendshiptrap.com

Jimmy Emerson (207) 483-6555 jemerson@friendshiptrap.com

Mike Wadsworth (207) 542-0841 mikew@friendshiptrap.com

Friendship Office: (800) 451-1200; (207) 354-2545

Columbia Falls Office: (800) 339-6558

Visit our website: www.friendshiptrap.com





New England Marine Engineering & Supply, Inc.

Marine • Industrial • Commercial • Refrigeration

10 TON ELECTRIC TITANIUM RSW
INTEGRATED MARINE SYSTEMS

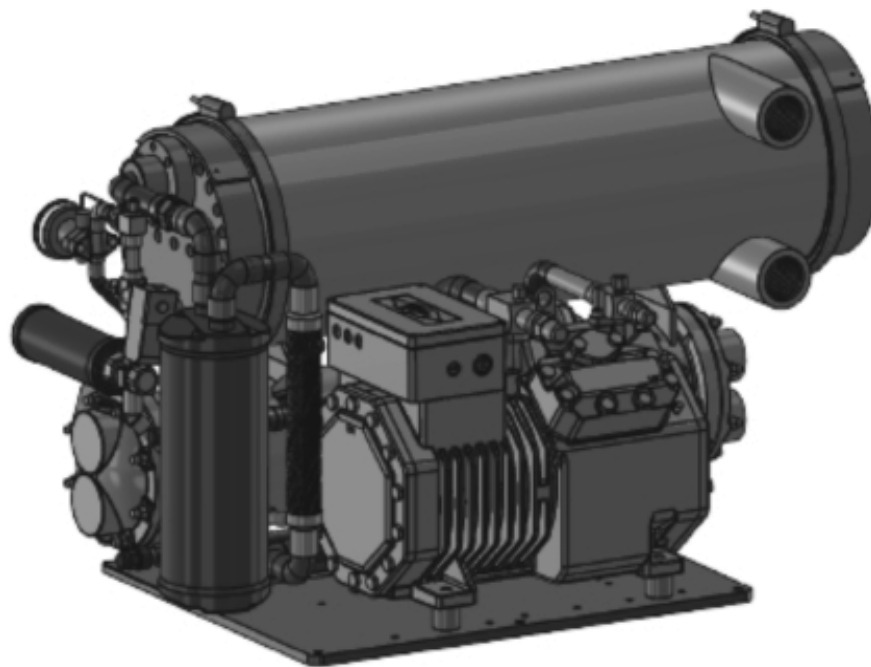

"New England Marine Engineering & Supply, Inc & Integrated Marine Systems, Inc is proud to announce & debut the new IMS 10 Ton Titanium Electric RSW at the 2018 Seafood Processing North America Show on March 11-13 Booth 1875. Come see us and be the first to view the latest IMS system to be introduced to the industry for the fishing vessels ranging from 40' - 80'.

It's going to be the talk of the show."

133 North Front Street, New Bedford, MA. 02740

www.nemesinc.com 1.800.540.8893



Service Provider for MLA Non-Profit Boat Protection Cooperative Ltd.

MLA's #1 Commercial Boating Insurance Provider

Agreed Hull Value – Protection & Indemnity

Crew Coverage – Extended Policy Limits – Chartering

Marina Floaters – Multiple Fisheries & Deductibles

Call 781-545-5073 for a free quote

or

request a quote online at fishermenservices.com



The Massachusetts Lobstermen's Association

would like to welcome the following new members to the Association.

Your Association will continue its efforts on your behalf to conserve the resource, protect your livelihood, keep you informed, promote the industry and provide you with increasing benefits as they are developed. MLA stands ready to help you in anyway, at anytime — just let us know how!

Safe on the water and good fishing!

NEW MLA MEMBER:

PETER WALLACE

Port: Pahrump, Nevada



Published by the Massachusetts Lobstermen's Association, Inc.
8 Otis Place, Scituate, MA 02066

— Published monthly —

Mailed to all paid members of the Massachusetts Lobstermen's Association

Newsletter Departments

Editor, Industry News, Notice Section,
Editorial, Blog, Industry News,
Promotions, Layout, Advertising:
Beth Casoni — Executive Director

Buy Sell Swap: Tracey Abboud

Newsletter Advertising Rates

The MLA Newsletter is published monthly
(Please note that all pre-paid ads
for last year will be honored)

\$50 — ¼ Page Ad

\$80 — ½ Page Ad

\$110 — Full Page Ad

Color Ads — + \$50 per ad

As the HAULER TURNS

As we say goodbye to 2023 and hello to 2024, this year has been one full of ups and downs in the fishery and hopefully 2024 will level out. The feedback I have been getting from all of you, is that the catch this year is all over the board and when the dust settles, let's hope there is black ink on your bottom-line.

This year there has been a lot of efforts put forth by the MLA and the state to educate consumers and promote the American Lobster. Earlier this fall, the Massachusetts Division of Marine Fisheries Director, Dan McKiernan, starred in a video to educate and promote the consumers on all the conservation efforts put forth by the commercial lobster industry here in the Commonwealth. This video can be found on YouTube here: <https://www.youtube.com/watch?v=O8FJLpeckKw>

With all these efforts to promote and educate consumers, there is still a gap in the cost at the dock vs. the plate. Consumers continually ask, "why do lobster costs so much in the res-

taurants and markets and lobstermen are being paid the same as they were 18 years ago"? What more can the MLA do, to help you, the commercial lobsterman get a better price? We are standing by waiting to hear from you as you know more than anyone about the unfair gap in pay rate.

Also, as the year comes to an end, the MLA is ramping up the preparations for the 2024 Annual Weekend and Industry Trade Show. This is the MLAs 61st event and we're still going strong. The Annual Weekend Committee is working hard to bring you the best vendors, educational seminars, and great entertainment.

Every year, the MLA Delegates vote to continue holding the MLAs Annual Weekend and Industry Trade Show for you. The amount of work it takes to pull this together is not an easy feat and your attendance is a simple way to say THANK YOU. If you have not attended this event, you are missing out as there are people that come from far and wide to catch up and have a laugh.



All the reservation forms are in this newspaper. Remember, this event is for YOU and the MLA needs you to show up and participate.

Lastly, this year for me has been a blur of wind, whales, safety, and marketing meetings along with a smattering of other meetings all of which have the commercial lobstermen in the center of it. I don't know why I am still astounded at how many individuals, groups, agencies, and organizations that are out there all to help you, the commercial lobstermen. There must be 25-30 individuals for each commercial fisherman standing by ready to help and these numbers keep growing.

Let's hope in 2024 the seas are calm, and the pots are full.

Safe on the water,

Beth Casoni

Executive Director
Massachusetts Lobstermen's
Association



HV MAINE
HAMILTON
MARINE
BOATERS' STORE!™

KITTERY
PORTLAND
ROCKLAND
SEARSPORT
SW HARBOR
JONESPORT

Shop our Holiday Flyer online or in-store and...
Save in waves.

Our flyer is filled to the brim with goodies for the boater in your family. From must have knives to stocking stuffers to cozy warm weather gear, there's something for everyone on your list!

I know these DEALS are
WICKED CRAZY but
I love the Holidays!

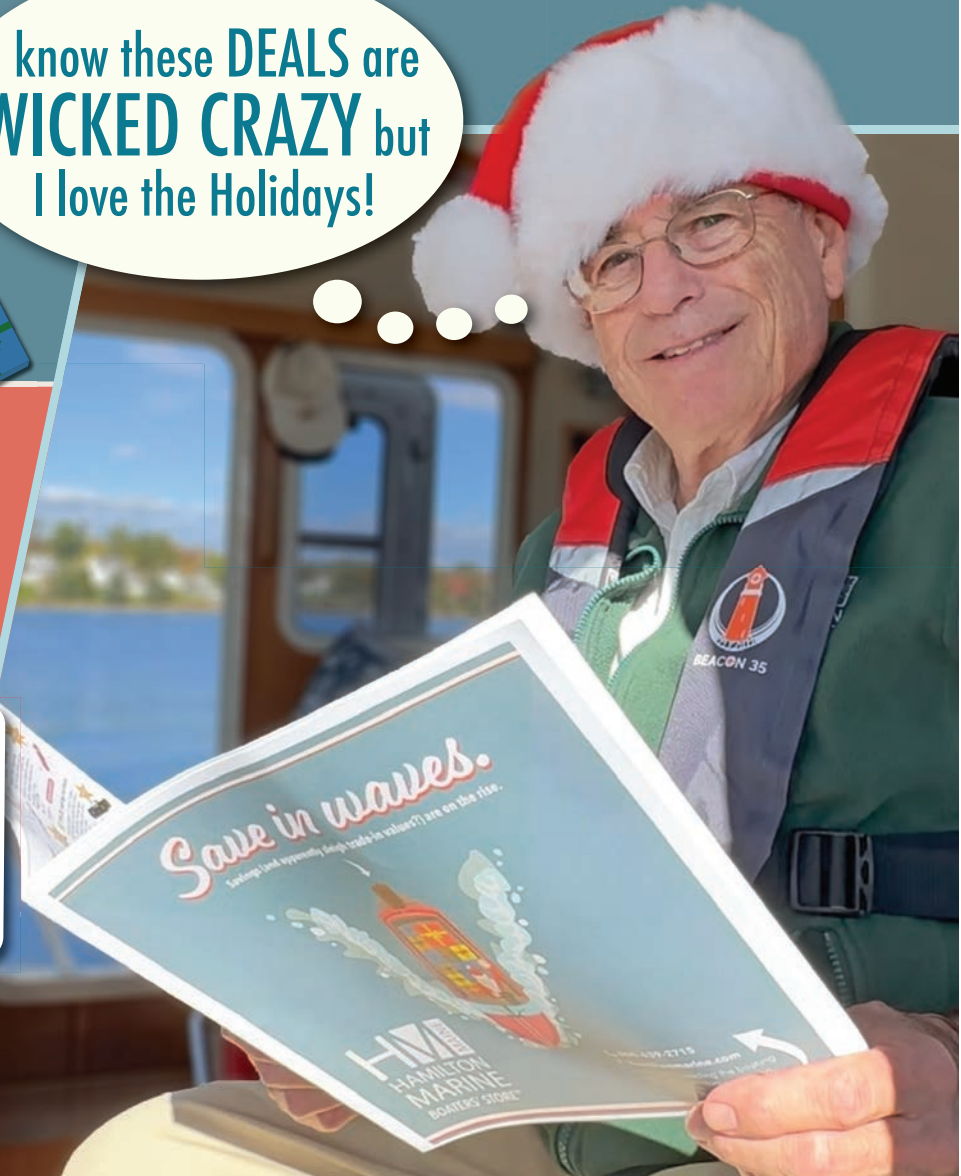

*Don't know what to get
the boater on your list?*

The one size fits all gift.

**Hamilton Marine
Gift Cards!**

Available in any
amount.

Order# GIFTCARD



800-639-2715



hamiltonmarine.com

Plus, keep an eye on social media! We're filling our sleigh with a selection of Super Specials that you don't want to miss out on!



The MLA's 60th Year in Review



As the Massachusetts Lobstermen's Association (MLA) 60th year ends this month, the MLA stands as a testament to the resilience and solidarity of the men and women who have made their livelihoods from the sea. Established to address the challenges faced by those in the lobster industry, the MLA has played a pivotal role in shaping policies, preserving traditions, and safeguarding the interests of Massachusetts lobstermen.

The roots of the MLA trace back to the mid-20th century when lobstermen faced a myriad of challenges, including fluctuating market prices, regulatory uncertainties, and envi-

ronmental concerns. Frustrated by the lack of representation, a group of lobstermen gathered to form an organization that would advocate for their interests and promote the sustainable management of the lobster fishery.

The MLA was officially established in 1963, bringing together lobstermen from various coastal communities across the state. In its early years, the association focused on fostering camaraderie among lobstermen, sharing knowledge about sustainable fishing practices, and advocating for fair and effective regulations to protect their livelihoods.

As the lobster industry grew, so did the challenges. The Massachusetts Lobstermen's Association became a powerful voice advocating for the interests of its members at both the state and federal levels. The organization engaged in discussions with regulatory bodies, fisheries management councils, and environmental agencies to ensure that policies were not only effective in conserving lobster stocks but also considerate of the economic well-being of those dependent on the industry.

One of the notable achievements of the MLA was its involvement in the development and implementation of measures to protect the North Atlantic right whale. Recognizing the importance of coexistence with marine life, the association worked collaboratively with researchers, conservationists, and policymakers to address concerns related to whale entanglements, demonstrating a commitment to responsible and sustainable fishing practices.

In addition to its advocacy work, the Massachusetts Lobstermen's Association has been instrumental in educating its members and the public about the lobster industry. The MLA organizes workshops, seminars, and outreach programs to promote best practices in lobstering, ensuring that generations of lobstermen are well-informed and equipped to adapt to evolving industry standards.

The MLA also plays a vital role in fostering a sense of community among lobstermen. Annual events, festivals, and gatherings organized by the association provide opportunities for lobstermen and their families

to come together, share experiences, and celebrate the heritage of their trade.

Over the years, the Massachusetts Lobstermen's Association has faced numerous challenges, including economic pressures, regulatory changes, and the impacts of climate change on lobster habitats. The association has consistently demonstrated its ability to adapt, evolving its strategies and initiatives to address the evolving needs of its members and the industry at large.

The Massachusetts Lobstermen's Association stands as a resilient and essential institution, safeguarding the interests of those who navigate the unpredictable waters of the lobster industry. From its humble beginnings to its current role as a powerful advocate for sustainable practices, the MLA continues to play a crucial role in preserving the livelihoods and traditions of Massachusetts lobstermen. As the association looks towards the future, it remains a beacon of strength and unity for the coastal communities that depend on the bounty of the sea.

OVER 20 YEARS EXPERIENCE ~ ALL MATERIALS & SIZES

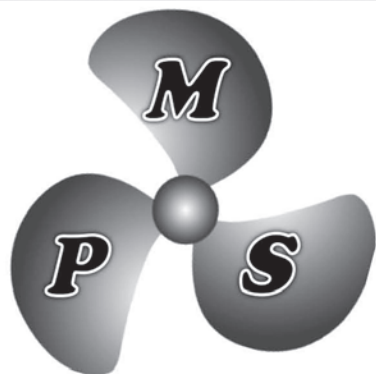

**FOR FAST SERVICE
CALL MIKE @
508.979.8000**

marine.propeller128@gmail.com

MARINE
PROPELLER SERVICE

REPAIRS &
RECONDITIONING
(Fast & Fully Insured)

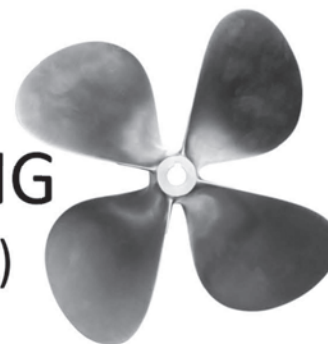

THE MOST RELIABLE PROPELLER SERVICE COMPANY ON THE SOUTHCOAST

74 MAIN STREET FAIRHAVEN MA 02719 508.979.8000 FAX 774.206.6449

2024 American Lobster Initiative Summit

ALI Regional Research & Outreach Summit

Registration for the second Regional Lobster Research & Outreach Summit for the Sea Grant American Lobster Initiative (ALI) is now open (register at 2024 ALI Summit - Maine Sea Grant (umaine.edu))! Maine Sea Grant will host the ALI Summit on **February 12-13, 2024**, at the [Portland Regency Hotel & Spa](#). The 2024 Summit will focus on building bridges across all groups harvesting, researching, and managing lobster to address and collaboratively develop solutions to new challenges the industry is facing.

We are still early in the planning process but envision this event as a way to bring the network together to share updates, receive feedback, and embark on new collaborative research and extension projects. Based

on input following our first in-person Summit and helpful suggestions from the ALI's Regional Steering Committee, we have developed the following plan for the 2024 Summit:

Day 1 (Monday, February 12):

- Morning plenary and panel discussion
- Lunch
- Afternoon topical area breakout sessions
- Evening social and poster session

Day 2 (Tuesday, February 13):

- Morning topical area breakout sessions
- Lunch

- Afternoon plenary and panel discussion

We plan to use the **plenary and panel discussion** portions of the meeting to focus on broad-scale issues relevant to all members of the ALI network, like how we can better engage our diverse partners in collaborative research to address emerging issues. We will then use the **topical area breakout sessions** to take a deeper dive into research topics through a combination of scientific presentations and facilitated discussion.

Since we are still working out the details for this event, we encourage you to fill out this form [American Lobster Initiative - Regional Lobster Research and Outreach Summit](#)

(<https://tinyurl.com/2b849cx3>) to help shape our agenda. We hope you will join us for this in-person event as we make connections across the many ALI-affiliated partners.

If you have any questions or concerns, please reach out to Amalia Harrington (amalia.harrington@umaine.edu).

Note: Room rates and booking information for the Regency are forthcoming and will be posted here once available.

Maine Sea Grant

5741 Libby Hall Suite 110
Orono ME 04469

Tel: 207.581.1435 Fax: 207.581.1426
Email: umseagrant@umaine.edu

Are you thinking of buying or selling?

Boats | State and Federal Permits | Complete Businesses

ATHEARN MARINE AGENCY, INC.



SERVING FISHERMEN SINCE 1946

Tel: (508) 999-4505

Email: sales@athearnmarine.com

www.athearnmarine.com

10 Union Wharf, Fairhaven, MA 02719





New England Marine & Industrial
www.newenglandmarine.com

Lobster Bands

We carry:

Sheddar

Standard

Cold Water Sheddar

Jumbo



Buy them by the 1 pound bag, by the case or by the pallet. We also offer wholesale and volume discounts. Call and ask to speak to a salesman.



Dayglo &
Flexabar
Buoy Paint

200 Spaulding Tpke
Portsmouth, NH
603-436-2836



Buoys:
Sea Alex
Polyform
Sea Master

Riverdale/Aquamesh Trap Wire

- Large inventory of trap wire in store
- Variety of sizes and colors available
 - Some trap kits in stock
- Order any size trap kits you may need

294 Ocean St
Brant Rock, MA
781-834-9301

86 Cemetary Rd
Stonington, ME
207-367-2692

RESEARCH FROM AMERICAN LOBSTER INITIATIVE

Life History Stage **HABITATS**

Simonne Dodge, Jennie Rheuban, and Stephanie Murphy | WHOI Sea Grant
December 2023

A team of scientists track influences on lobsters' journeys from egg to postlarvae

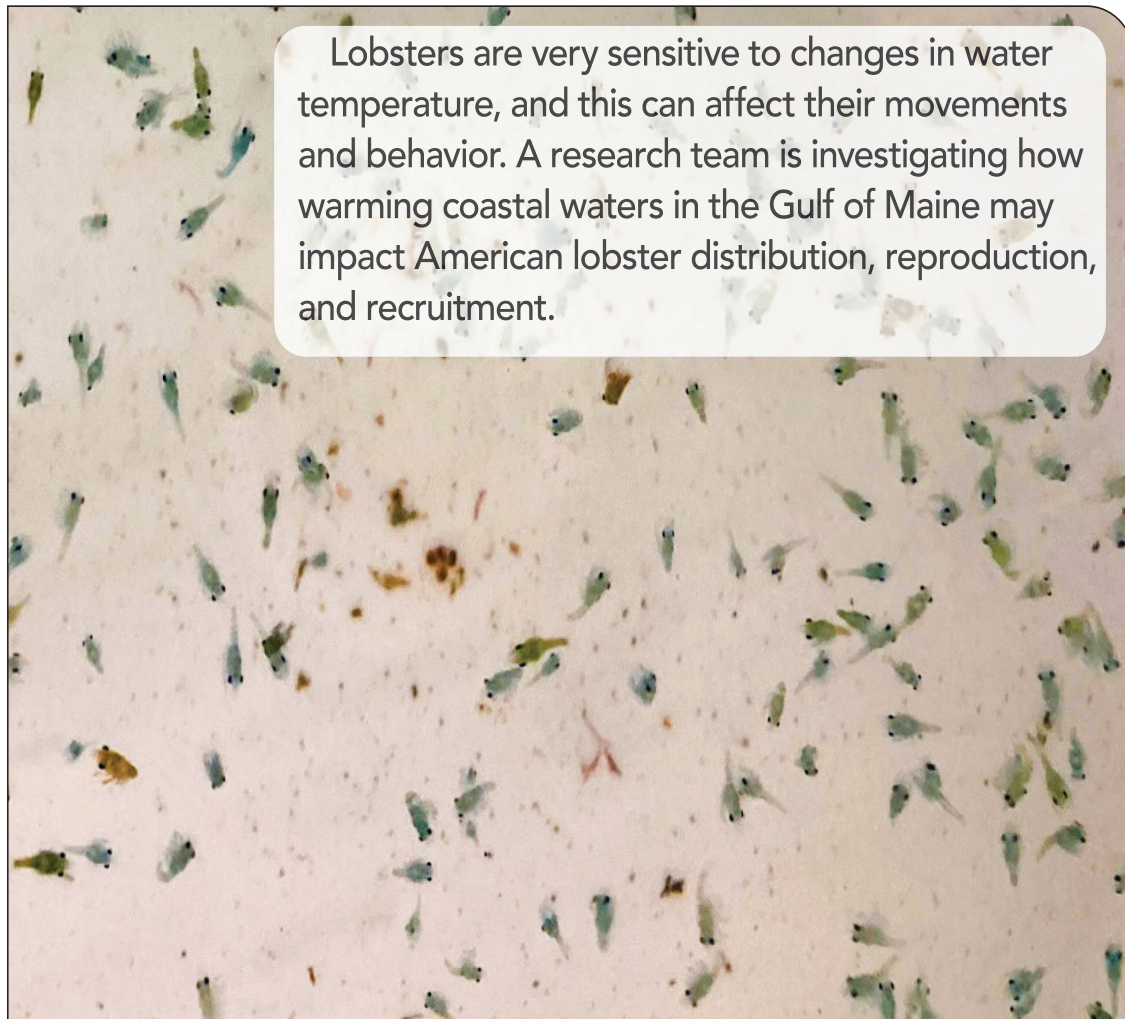

Lobsters are very sensitive to changes in water temperature, and this can affect their movements and behavior. A research team is investigating how warming coastal waters in the Gulf of Maine may impact American lobster distribution, reproduction, and recruitment.

Early stage lobster larvae. Photo: Jason Goldstein, Wells National Estuarine Research Reserve

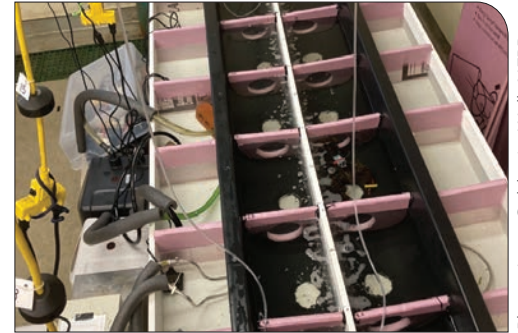

Photo: Jason Goldstein, Wells NERR

Tanks for measuring ovigerous lobsters' preferred water temperature.

EXPLORE the PROJECT

The research project has three distinct components. 1) the team is conducting lab experiments on reproductive females to determine which temperatures are preferred by mature female lobsters with or without eggs; 2) the team constructed ocean drifters (buoys with GPS units) to float on ocean currents to help predict the paths of drifting lobster larvae; 3) the researchers are examining the swimming capabilities of the post-larval stage in the lab and in the field to determine if their swimming duration changes under varying temperatures and currents.

To explore more research stories from American Lobster Initiative, visit our StoryMap collection:

<https://arcg.is/1CHT1j>



RESEARCH FROM AMERICAN LOBSTER INITIATIVE



Photo: Jason Goldstein, Wells NERR

Ocean drifters are prepped and ready to be released.



Photo: Abbey Sisti, VIMS

An adult American lobster.

READ the RESULTS

1) Female lobsters preferred warm waters in the summer and fall and cold waters during the winter and spring. In the summer, as the ovigerous lobsters' eggs neared hatching, these females opted for cooler waters than their non-ovigerous counterparts, becoming most active when their eggs began hatching. 2) In summers of 2020 and 2021, drifters were released to track the potential courses of lobster larvae in Gulf of Maine currents. 3) When faced with a continuous current, postlarvae in warm waters stopped swimming sooner than those in cold water.

UNDERSTAND the IMPORTANCE

Understanding the movements of reproductive lobsters is key for estimating where lobster larvae are beginning their drifting journeys once they hatch. Additionally, the ability to know where these larvae will likely settle on the seafloor will provide scientists with a better understanding of how the lobster population as a whole is distributed throughout the Gulf of Maine. This is an important piece of information for lobstermen and management alike.



Wells National Estuarine Research Reserve

Jason Goldstein, PhD PRINCIPAL INVESTIGATOR

Jason is the research director at the Wells National Estuarine Research Reserve, an adjunct assistant professor at York County Community College, and an affiliate research professor at UNH.



We welcome your feedback.
Email us at lobster@whoi.edu

RESEARCHER HIGHLIGHT



Wells National Estuarine Research Reserve

Jason Goldstein – Wells National Estuarine Research Reserve

Jason's career working with lobsters began after college with an internship at the New England Aquarium's Edgerton Research Lab, handling lobster eggs, larvae, and juveniles. He earned a PhD from the University of New Hampshire (UNH) and was awarded a U.S. Fulbright Post-Doctoral

Research Fellowship at the University of Haifa in Israel. He is now the research director at the Wells National Estuarine Research Reserve (ME), as well as an adjunct assistant professor at York County (ME) Community College and an affiliate research professor at UNH.



November 7, 2023

Last May, we communicated that Neptune LNG, LLC is evaluating the decommissioning of its offshore facility, the Neptune Deepwater Port (the Port). The Port is located in Massachusetts Bay, about twenty-two miles from Boston. As a reminder, the Port consists of two underwater buoys and a subsea pipeline designed for the importation of natural gas to the New England region. As a result of significant changes in natural gas supply in the U.S. and a focus on renewable energy in Massachusetts and New England, the Port has been inactive since its commissioning in 2010. The purpose of this communication is to update you on Neptune's decommissioning evaluation.

Neptune is developing a draft decommissioning plan (the Plan) and intends to submit it to the U.S. Department of Transportation, Maritime Administration and the U.S. Coast Guard in December of 2023. The Plan will include Neptune's preferred method of decommissioning as well as the potential environmental effects of the various alternatives. As part of preparing the Plan, Neptune conducted marine surveys of the Port from July to early November. In addition, we have been meeting regularly with both State and Federal agencies to ensure all regulatory require-

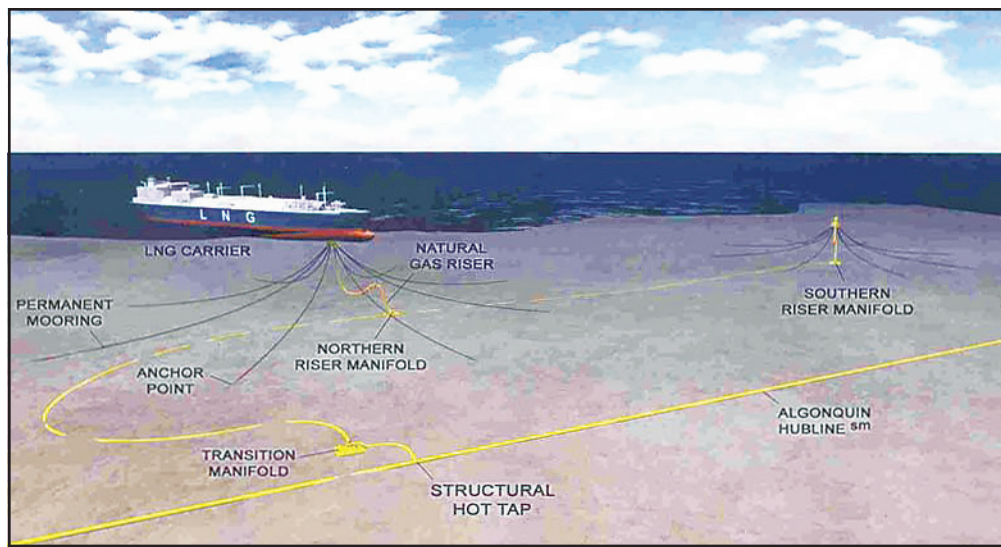

Illustration of the Neptune Deepwater Port

ments are met. We welcome the opportunity to discuss our plans with you as well as to maintain an open line of communication to understand and attempt to address issues that may be important to you.

We will continue to provide updates regarding this project as new or updated information be-

comes available. If at any time you have any questions or concerns or would like to meet in person, on the phone, or virtually, please do not hesitate to contact our Public Affairs colleague Julie Vitek at julie.vitek@engie.com or 617-593-2122.

*Sincerely,
The Neptune LNG Team*

ROPE RECYCLING AND SWAP

100 lbs = 3 coils of redrope or candy cane

midwater trawl, codend bottom trawl net, footrope, seine web (any color), chafing gear, purse line, float line (from pot gear), stripped gillnet web (no twine), weedline, sink line, and lead and cork line from gillnets

MLA OFFICE IN SCIUATE - 12/7 FROM 12-4PM
1/8/2024 in Gloucester - location to be determined

or
by appointment at
143 King Street New Bedford MA
 Contact Caitlin Townsend 774-316-0417
caitlin@netyourproblem.com

 **NET YOUR PROBLEM**

GIVE YOUR BRAIN

AS MUCH



ATTENTION

AS YOU  **GIVE YOUR**

DINGHY

THERAPY THE WAY A FISHERMAN DOES IT
MAN THERAPY.ORG



Rose Marine

www.rosesmarine.com

877-283-3334

Gloucester, Mass

Aqualoy Stainless Propeller Shafts & Accessories



WBM
WESTERN BRANCH METALS, LC

- Best Pricing
- Largest Inventory
- Fastest Turnaround

Call Peter Tetrault for a shafting quote

Hydraulic Valves in Stock



Commercial
DVA20 – 40 GPM
DVA35 – 60 GPM



Gresen25P W4
35 GPM – SS Spool



Cross SBA2
30 GPM - Replaces SPW4



Spiral Baffled
Mufflers



BelMar
Industries



Critical Grade,
In-Line Mufflers



Stainless Steel
In-Line Mufflers



Hydraulic Hoisting Winches

2850 lb & 10,000 lb
Hoisting Capacity
IN STOCK

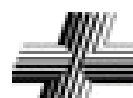

RIVERDALE

Trap Repair Wire
In Stock



6" - \$99
13" - \$159
16" - \$235

Prices based on current stock.

"TYTAN" 7/16" Sink Rope in Stock



\$169 per
1200' Coil

"Steel Haul" 3/8" Sink Rope in Stock



\$155 per
1200' Coil

Prices based on current stock.

TIPS & SUGGESTIONS FOR FISHERMEN

It is likely unrealistic for most fishermen to get a full 8 hours of sleep while fishing. However, there are other practical solutions that fishermen can utilize to offset the effects of sleep deprivation.

Diet and reducing inflammation

Focusing on your diet and eating anti-inflammatory foods can promote good health and combat the negative effects of sleep deprivation. In fighting inflammation, your diet is one of the most powerful tools that you have! Many major diseases like cancer, heart disease, diabetes, arthritis, depression and Alzheimer's have been linked to chronic inflammation.

“I feel a lot better when I am able to rest correctly and eat correctly.”

Increasing Hydration

Tie drinking more water into your routine! Every time you wake up, use the bathroom, eat a meal, take a break, etc., have some water. If you're not a fan of water, flavor it with powder or liquid water enhancers. Eating fruits and veggies with high water content is also helpful!

Signs of dehydration include fatigue, confusion and short term memory loss, headache, dizziness and/or lightheadedness, dry mouth, lips and eyes. It is important to note that dehydration has been linked to repetitive musculoskeletal injuries, a prevalent risk for fisheries workers given repetitive and strenuous work tasks.

Anti-inflammatory Foods



Tomatoes



Fruits

Strawberries, oranges, blueberries, cherries, etc



Nuts

Almonds, Walnuts, and other nuts



Olive Oil



Leafy Greens

Spinach, kale, collards, and more



Fatty Fish

Salmon, mackerel, tuna, and sardines

Inflammatory Foods



Fried Foods



Sodas



Refined Carbs



Lard



Processed Meats

Correct Hydration



TRANSPARENT

You're overhydrated. Hold off on the water for a bit.



LEMONADE

This is optimal hydration. Keep doin' what you're doin'.



LIGHT BEER

You're still hydrated and doin' great.



AMBER

No need to fret, but time to drink some water. You could be mildly dehydrated.



BURNT ORANGE

You're definitely dehydrated. Drink lots of water and electrolytes.

Serving Lobster for an Extraordinary Christmas Feast



As Christmas approaches, many households turn to traditional favorites like roast turkey or glazed ham for the festive feast. However, for those seeking to elevate their holiday celebration with a touch of indulgence and maritime flair, consider the luxurious option of serving lobster. Embracing lobster as the centerpiece of your Christmas table adds a decadent twist to the season's culinary traditions, creating a memorable and mouthwatering experience for family and friends.

Lobster has long been associated with special occasions and celebratory feasts. Historically considered a delicacy, lobster was often reserved for significant events, making it an ideal choice for a holiday as festive as Christmas. Its succulent, sweet meat and vibrant presentation add a touch of opulence to the table, transforming a regular meal into a luxurious dining experience.

Selecting high-quality lobsters is paramount for a successful Christmas feast. Freshness is key, so consider purchasing live lobsters from a reputable seafood market. The vibrant colors, lively movement, and firm shells are indicators of the lobster's freshness.

There are various ways to prepare lobster, each offering a unique flavor profile. Classic methods include boiling, steaming, grilling, or baking. For a truly indulgent experience, consider lobster thermidor or lobster Newberg, both rich and flavorful dishes that showcase the lobster's exquisite taste.

Complement the lobster with festive side dishes and pairings. Classic ac-

companiments include drawn butter, lemon wedges, and a selection of dipping sauces. Consider pairing lobster with champagne or a crisp white wine to enhance the dining experience.

Get creative with your lobster recipes to infuse a personalized touch into your Christmas feast. Lobster macaroni and cheese, lobster bisque, or lobster-stuffed mushrooms are delightful appetizers that set the tone for a lavish meal.

For a truly extravagant affair, incorporate lobster into multiple courses. Begin with a lobster salad or bisque as an appetizer, follow with a lobster main course, and conclude with a decadent lobster dessert or pastry. This ensures a consistent theme of luxury throughout the meal.

For households with diverse tastes, consider family-friendly lobster options. Lobster rolls, lobster pasta, or even lobster pot pie provide a more approachable way to introduce this exquisite ingredient to those who may be trying lobster for the first time.

Serving lobster at Christmas is a delightful departure from tradition, adding a touch of elegance and luxury to the holiday festivities. Whether you opt for classic preparations or get creative with unique lobster recipes, the rich and succulent flavors of lobster are sure to make your Christmas feast an unforgettable celebration. Embrace the spirit of the season with a decadent twist, creating lasting memories and establishing a new tradition that will have your loved ones looking forward to lobster on Christmas for years to come.



Connecting You to Massachusetts Health Insurance Year-Round

2024 Open Enrollment
November 1, 2023 - January 23, 2024

Fishing Partnership Navigators can help any MA resident under 65 access health insurance. We can help you understand your eligibility, make changes to your application, search for providers, and find a plan that best suits the health needs of you and your family.

New in 2024: individuals earning \$72,900 annually (or \$150,000 for a family of 4) may be eligible for lower premiums and subsidies towards their health plan.

Contact a Navigator anytime during the year to apply, renew your MassHealth, or make changes to your application.

Apply and make a payment by January 23rd to have coverage that begins February 1st.

New Bedford Office

398 County Street
New Bedford, MA 02740
508.991.3043

South Shore Office

139 Court Street
Plymouth, MA 02360
508.746.5400

Cape & Islands Office

894 Main Street
Chatham, MA 02633
774-840-9393

North Shore Office

2 Blackburn Center
Gloucester, MA 01930
978-282-4847



Scan to request
HEALTH INSURANCE Services
FISHINGPARTNERSHIP.ORG



Massachusetts maintains a mandate for all individuals to have health insurance. Uninsured residents could pay a state tax penalty. Don't risk it - call a Navigator & get covered today!

Fishery Management Actions

American Lobster

In October, the Commission's American Lobster Management Board modified the implementation date for measures under Addendum XXVII to Amendment 3 to the Interstate Fishery Management Plan for American Lobster to January 1, 2025 (see table for specific dates). Addendum XXVII was adopted in May 2023, and established a trigger mechanism to automatically implement management measures to provide additional protection of the Gulf of Maine/Georges Bank (GOM/GBK) spawning stock biomass.

Under Addendum XXVII, changes to gauge and escape vent sizes in Lobster Conservation Management Areas (LCMAs) 1 (Gulf of Maine), 3 (offshore federal waters) and Outer Cape Cod (OCC) would be initiated based on an observed decline in recruit abundance indices of 35% from the reference level (equal to the three-year average from 2016-2018). With the inclusion of recently released 2022 data in the time series, the trigger index has declined by 39%, surpassing the trigger point of a 35% decline. The measures triggered include two increases to the minimum gauge size in LCMA 1, a corresponding change in the LCMA 1 escape vent size, and a single decrease to the maximum gauge size in LCMA 3 and OCC.

"Because the trigger was tripped much more quickly than we anticipated, the delay in implementing the gauge size increase will provide the Gulf of Maine states the opportunity to coordinate with Canada regarding possible trade implications, and give the industry and gauge makers additional time to prepare for these changes," stated Pat Keliher from Maine.

Addendum XXVII also implements a standard v-notch definition of 1/8" with or without setal hairs in LCMA 3 and OCC, and a standard maximum gauge size of 6 3/4" for state and federal permit holders in LCMA 3 and OCC. Additionally, for LCMA 1 and 3 permit holders, states must limit the issuance of trap tags to equal the harvester trap tag allocations unless trap losses are documented. The implementation date for these measures is now January 1, 2025.

For more information, please contact Caitlin Starks, Senior Fishery Management Plan Coordinator, at cstarks@asmfc.org.

Horseshoe Crab

In October, the Commission's Horseshoe Crab Management Board approved harvest specifications for Delaware Bay-origin horseshoe crabs. Taking into consideration the output of the Adaptive Resource Management (ARM) Framework Revision, the Board set a harvest limit of 500,000 male and zero female Delaware Bay-origin horseshoe crabs for the 2024 season.

Timing of Management Changes for LCMAs 1 and 2, and Outer Cape Cod under Addendum XXVII as Modified

When change(s) will be implemented	What change will be implemented		
	LCMA 1	LCMA 3	Outer Cape Cod
January 1, 2025	Trap tags issuance limited to harvester allocation		v-notch definition: 1/8" with or without setal hairs; Maximum gauge size: 6 3/4"
January 1, 2025	Minimum gauge size: 3 5/16"		
January 1, 2027	Minimum gauge size: 3 3/8"		
January 1, 2028	Escape vent size: 2 x 5 3/4" rectangular; 2 5/8" circular		
January 1, 2029		Maximum gauge size: 6 1/2"	Maximum gauge size: 6 1/2"

"The Board stands behind the ARM Framework Revision as the best available tool to set harvest limits for horseshoe crabs of Delaware Bay-origin. As a result of its use, the Delaware Bay horseshoe crab population has been increasing, with abundance of both female and male horseshoe crabs in the Delaware region at an all-time high since 2003. Despite this positive finding, the Board elected to implement zero female horseshoe crab harvest for the 2024 season as a conservative measure, considering continued public concern about the status of the red knot population in the Delaware Bay," stated Board Chair John Clark of Delaware.

To make up for the lost harvest of larger female crabs, the Board agreed to increase Maryland and Virginia's male harvest quotas with an offset ratio of 2:1 males to females. Using the allocation methodology established in Addendum VIII, the following quotas

State	Delaware Bay-Origin Horseshoe Crab Quota (no. of crabs)	Total Quota**
	Male Only	Male Only
Delaware	173,014	173,014
New Jersey	173,014	173,014
Maryland	132,865	255,980
Virginia*	21,107	81,331

*Virginia harvest refers to harvest east of the COLREGS line only

**Total harvest quotas for Maryland and Virginia include crabs which are not of Delaware Bay-origin.

were set for New Jersey, Delaware, Maryland, and Virginia: For more information, please contact Caitlin Starks, Senior Fishery Management Plan Coordinator, at cstarks@asmfc.org.

Jonah Crab

The 2023 Jonah Crab Benchmark Stock Assessment and Peer Review Report indicates the range-wide population of Jonah crab remains above historic lows of the 1980s and 1990s. However, evidence of declining catch per unit effort (CPUE) in the fishery presents substantial concern and uncertainty for the status of the stock.

Based on life history and fishery characteristics, the assessment divided the population into four stocks: offshore Gulf of Maine (OGOM), inshore GOM (IGOM); offshore Southern New England

continued on next page

(OSNE) and inshore SNE (ISNE). According to the stock indicators, IGOM, OGOM, and OSNE recruit, exploitable, and spawning abundance conditions from 2019-2021 were neutral or positive relative to historical periods. Indicators generally agree across these stocks that abundance has not been depleted compared to the historic low abundance observed in the 1980s and 1990s. There are no reliable abundance indicators for the ISNE stock so no determination about the condition of this stock's abundance could be made at this time. Young-of-the-year settlement indicators generally show neutral conditions and do not indicate that recruitment in the GOM stocks will decline to historical lows in the near future. Settlement conditions are unknown for SNE stocks.

"As the first range-wide assessment of Jonah crab along the Atlantic coast, this assessment represents a significant advancement in our understanding of the species, its life history characteristics, and distinct fisheries by stock unit," stated Board Chair Jason McNamee of Rhode Island. "I commend the members of the Stock Assessment Subcommittee and Technical Committee for their successful completion of a challenging, data poor assessment."

According to the Peer Review Panel, "Despite the limited availability of current data, there is considerable urgency for the assessment due to a very steep, three-year decline in landings. Commercial landings have declined 51% in three years, after an unprecedented 30-fold rise in landings. Although the recent decline is not well-detected in fishery-independent stock indicators, there is some evidence of declining CPUE in the fishery, creating substantial concern and uncertainty for the status of the stock. Given the mixed signals, the status of the Jonah crab stock is highly uncertain."

Current conditions closely resemble early stages of the collapse of the Canada Jonah crab fishery in the early 2000s. In the first three years of the crash, Canada landings dropped 58%. Within five years, landings fell 97%, and stock biomass could no longer support a fishery. Fishery-independent trawl indicators had not fully captured the signals of a rapidly declining stock. However, declining fishery CPUE was observable preceding and during the landings crash.

Given the high level of uncertainty in the status of the Jonah crab stock, the Panel strongly recommends close monitoring of annual stock indicators in the next few years. Annual indicators can determine whether sharply declining recent landings are signaling the start of a 'bust' phase of a boom-and-bust arc, or are due to fishery and market-related factors uncoupled with Jonah crab abundance."

There are notable differences between the fisheries that operate in each of the stock areas. The vast majority of coastwide landings have come from the OSNE stock, accounting for 70-85% of annual coastwide landings from 2010-2021. The IGOM stock has supported the second largest fishery, accounting for 9-24% of annual coastwide landings from 2010-2021. Both the ISNE and OGOM have supported smaller fisheries, never accounting for more than 5% of annual coastwide landings from 2010-2021.

Jonah Crab Commercial Landings by Stock Area

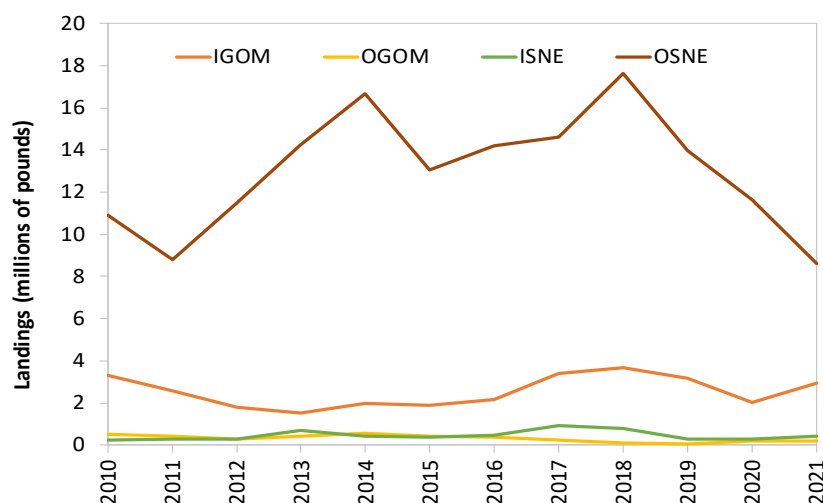

The high proportion of participants contributing to Jonah crab landings indicates a directed fishery in the OSNE stock that targets Jonah crab, yet only a small number of participants account for the large magnitude of landings from this stock. The other three stocks have fisheries that are characteristic of bycatch fisheries that are targeting American lobster. These fisheries have low proportions of participants that land Jonah crabs from pot/trap gears. In the case of the IGOM stock, there is a relatively high number of participants targeting lobsters and not landing Jonah crabs. This represents considerable capacity for growth in a Jonah crab fishery if these participants were to switch to targeting Jonah crab.

Landings have shown different trends across stocks, but the landings from OSNE declined steadily from the time series high in 2018 (17.6 million pounds) in the last three years of the time series (2019-2021). This trend is believed to be influenced by factors other than available abundance but should continue to be monitored closely. There was insufficient information to describe fishing mortality or exploitation with confidence and these population parameters remain major uncertainties.

In response to the assessment findings and peer review panel recommendations, the American Lobster Management Board accepted the Benchmark Stock Assessment and Peer Review Report for management use and tasked the Technical Committee with recommending possible measures or actions to address the concerns about stock status and recent fishery trends.

A stock assessment overview, which provides a more detailed description of assessment results, as well as the stock assessment and peer review report are available on the Commission's website at <https://asmfc.org/species/jonah-crab> under Stock Assessment Reports. For more information on the stock assessment, please contact Jeff Kipp, Senior Stock Assessment Scientist, at jkipp@asmfc.org; and for more information on Jonah crab management, please contact Caitlin Starks, Senior Fishery Management Plan Coordinator, at cstarks@asmfc.org.



NEW ENGLAND PROPELLER, INC.

Distributor of Michigan Propellers

Inboard • Outboard

Next Generation 3D Computerized Propeller Analyzer
Computerized Dynamic Balancing



Marine Fuel Tanks

Custom Fabricated & Tested to U.S.C.G Specifications
By Capeway Welding

- Marine Propeller Sales & Repairs - ***4000 Props in Stock***
 - Sierra Engine Parts for All Outboards & IOs
 - CDI Electronics • Camp & Godfrey Zincs
 - NGK Spark Plugs
 - Duramax Cutless Bearings • Spurs Line Cutters
 - PSS Dripless Shaft Seals
 - Buck Algonquin - Struts, Rudders & Stuffing Boxes
 - S/S Shafting • Drive Savers • Globe Impellers



9 Apollo Eleven Rd., Plymouth, MA 02360
Tel: 508-747-6666 800-635-9504 - neprop.com



Atlantic States Marine
Fisheries Commission
NEWS RELEASE

ASMFC Begins Preparations for American Lobster Benchmark Stock Assessment

Arlington, VA – The Atlantic States Marine Fisheries Commission has initiated a benchmark stock assessment for American lobster (*Homarus americanus*) to be completed in the summer of 2025. The goals of the assessment are to evaluate the health of stocks along the US Atlantic coast and inform management of this species. The Commission’s stock assessment process and meetings are open to the public, with the exception of discussions of confidential data*, when any meetings will be closed to the public.

The Commission welcomes the submission of data sets that will contribute to the goals of the assessment. This includes, but is not limited to, data on abundance (young

of year, recruits, adults), biological samples (sex, maturity, weight, carapace length), life history information (growth, natural mortality, shell disease, tagging data), catch (harvest, discards, fishing effort) and information regarding the environmental influence on lobster population dynamics. For data sets to be considered, the data must be sent in the required format, with accompanying description of methods, to the Commission by January 8, 2024.

The Data Workshop will be conducted in February 2024 (dates and location to be determined). This workshop will review available data sources for American lobster and identify data sets to be incorporated in the stock assessment. For those

interested in submitting data, please contact Jeff Kipp, Senior Stock Assessment Scientist, at jkipp@asmfc.org or 703.842.0740.

*Each state and federal agency is responsible for maintaining the confidentiality of its data and deciding who has access to its confidential data. In the case of our stock assessments and peer reviews, all analysts and, if necessary, reviewers, have been granted permission by the appropriate agency to use and view confidential data. When the assessment team needs to show and discuss these data, observers to our stock assessment process are asked to leave the room to preserve confidentiality. PR23-28



Encore Hartco Tools & Clips
Stanley Spenax Tools & C-Rings
Wematic Tools & D-Rings
Simonds Pneumatic Wire Cutters
Spotnail Staplers & Staples

Complete Parts Inventory
Tool Repair Service



(781) 826-2522
Fax (781) 826 5252
www.fisherairfasteners.com
chris@fisherairfasteners.com

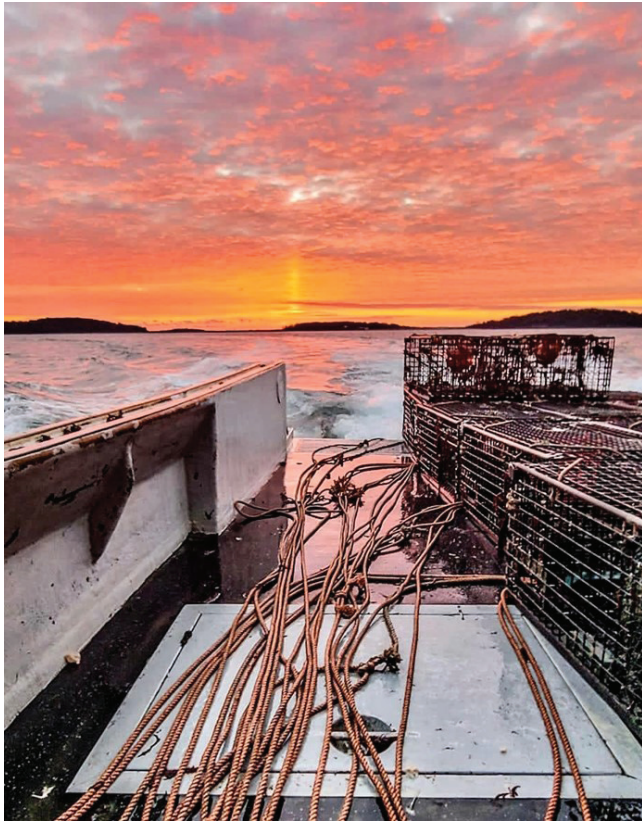



Simulating Climate Change IMPACTS

Simonne Dodge, Jennie Rheuban, and Stephanie Murphy | WHOI Sea Grant
December 2023

A research team works to fill critical knowledge gaps about how warming temperatures may affect aspects of lobster growth and development

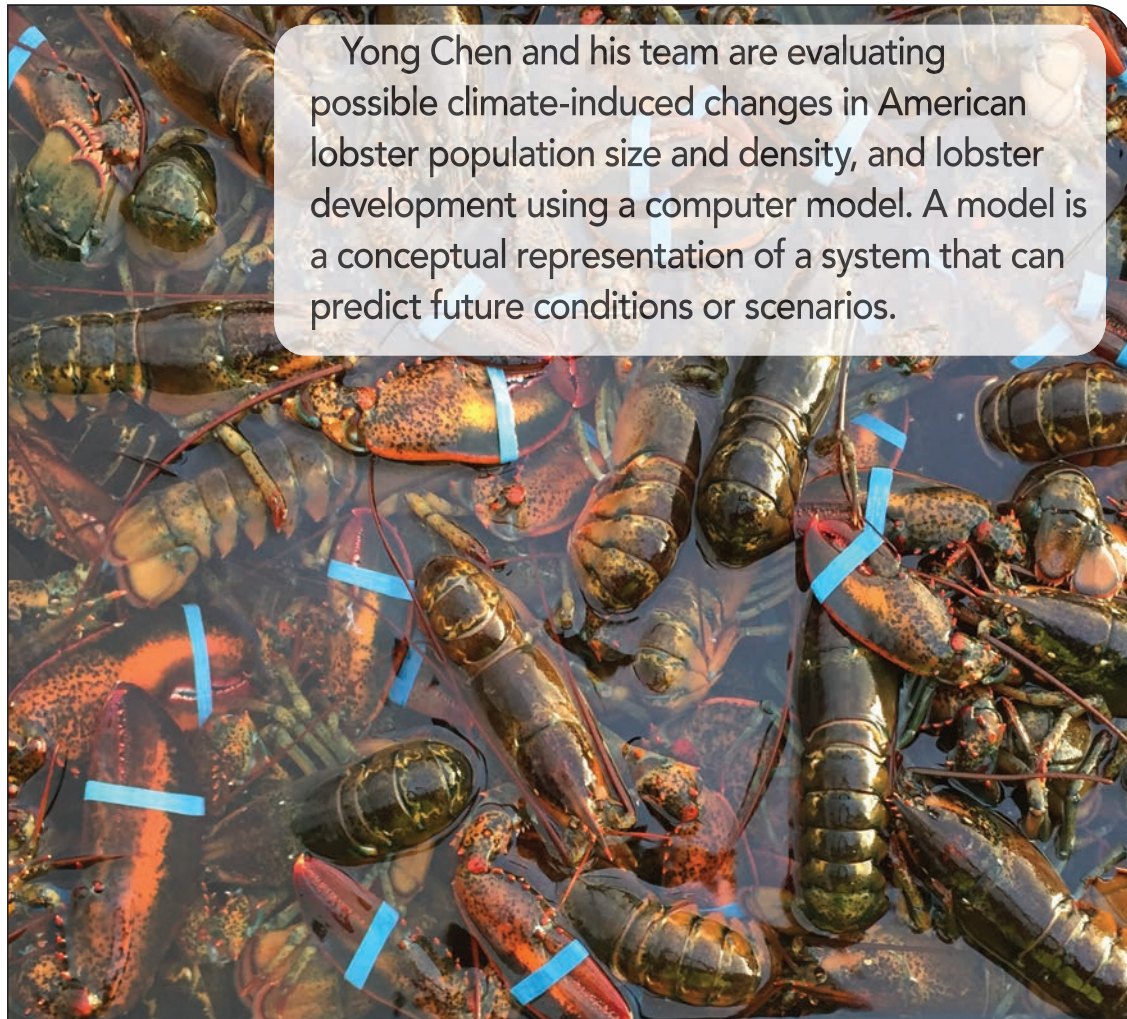

Yong Chen and his team are evaluating possible climate-induced changes in American lobster population size and density, and lobster development using a computer model. A model is a conceptual representation of a system that can predict future conditions or scenarios.

Photo: Chris Bartlett, Maine Sea Grant

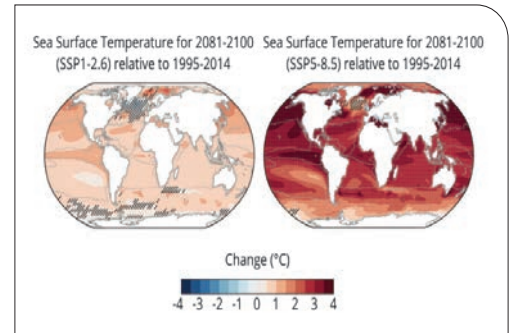

Projected sea surface temperature change in two scenarios.

Graphic: Gutiérrez, et al.

EXPLORE the PROJECT

The researchers are analyzing scientific papers to identify realistic ranges of change in the American lobster's molting times, growth rates, maturity levels, and mortality risks. The team is updating the Individual-Based Lobster Simulator (IBLS), a model developed by Chen and his colleagues in 2005, with temperature influences and recent population estimates to evaluate how lobsters will fare under various potential management strategies and environmental conditions. Their analysis also includes whether alternative management practices, e.g., changes to the minimum legal harvest size and other conservation measures, change the population's response to rising temperatures.

To explore more research stories from American Lobster Initiative, visit our StoryMap collection:

<https://arcg.is/1CHT1j>



RESEARCH FROM AMERICAN LOBSTER INITIATIVE



Photo: Amalia Harrington, MESG

A researcher uses a caliper to measure the length of a lobster.



Photo: Nathalie Straiger-Gutierrez, NOAA

A lobster molting after short-term lab exposure.

READ the RESULTS

Using available data from past long-term lab studies to test changes in growth rates and size at maturity in lobster population models, researchers found the modeled number of lobsters was not sensitive when these parameters changed one at a time. They found the lobster abundance did increase in a scenario when both lobster growth and size at maturity changed jointly under conditions that reflected end of century temperatures. The researchers suggested that additional research into these effects in the wild, or under short-term lab conditions is needed.

UNDERSTAND the IMPORTANCE

When predicting future population trends and making management decisions, it is valuable to be able to consider the effects of warming on lobster growth and development, as well as examine how the lobster population will respond to differing management practices. This project will add to a comprehensive understanding of the dynamics between lobsters and their environment, allowing fisheries management to be as robust as possible in the face of climate change.



Yong Chen, Stony Brook University

Yong Chen, PhD PRINCIPAL INVESTIGATOR

Chen is a professor in the School of Marine and Atmospheric Sciences at Stony Brook University.



We welcome your feedback.
Email us at lobster@whoi.edu

RESEARCHER HIGHLIGHT



Cameron Hodgson, Stony Brook University

Cameron Hodgson – Stony Brook University

Cameron was raised on the Maine coast. He grew up on lobster boats, listening to the captains tell stories and became fascinated with the dynamics of the ecosystem and how it was changing. Instead of becoming a fisherman like his father, he decided to study the ocean. He earned his undergraduate

degree at the University of New England and his PhD at the University of Maine. Today, he is a postdoctoral researcher in Chen's lab at Stony Brook University focusing on the American lobster fishery.

AQUAMESH®

AMERICAN MADE designed for the LONG HAUL

Since 1980 Aquamesh® has revolutionized the marine industry. It's designed to be weather and corrosion resistant to withstand the harshest marine conditions.

Designed and manufactured in Massachusetts with pride, by lobstermen who know the superiority of Aquamesh®

- Proven Quality and Durability
- Precision Engineered
- Fastest Fishing Mesh
- Unmatched Corrosion Resistance
- The Highliner's Top Choice



Rebekah,
3rd generation lobsterman.



Aquamesh® | Manufactured by Riverdale Mills
riverdale.com | sales@riverdale.com | 1.800.762.6374



**SAVE
THESE
DATES**



The Massachusetts Lobstermen's Association

**Annual Weekend
& Industry
Trade Show** 2024

March 21-24, 2024

(Vendor setup is on the 21st)

Emerald Resort & Conference Center at Hyannis, MA

*More information and reservation forms will be posted on the
MLA's website www.lobstermen.com*

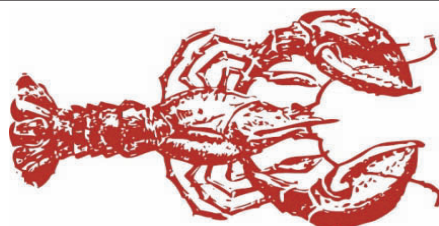

**“Specializing in the sale & delivery of
LOBSTER BAIT
for over 30 years”**

FRESH FROZEN AND SALTED BAIT AVAILABLE

**SKATES ~ HERRING ~ POGIES ~ HADDOCK ~ COD FISH ~ POLLOCK
FLAT FISH ~ FISH SKINS ~ RED FISH ~ DOG FISH HEADS ~ SALMON**



**C & P BAIT
33 Wright St
New Bedford, MA 02740**

**Contact:
Danny Costa 508-951-9818
Carlos Pereira 508-951-9819**



MEMBER/ATTENDEE INFO

Annual Weekend & Industry Trade Show 2024

March 21-24, 2024

Dear MLA member and Annual Weekend attendee,

In an effort to reduce our carbon footprint on the earth we are now going paperless and all the information and registration forms will be sent out in our weekly emails and are available on the MLA's website Annual weekend page www.lobstermen.com. If you would like the registration forms mailed to you directly, please call the MLA office and speak with Tracey at 781.545.6984 Ext.2.

The 2023 MLA Annual Weekend and Trade Show is scheduled for March 21-24, 2024 at the Emerald Resort, 35 Scudder Ave, Hyannis, MA 02601.
<https://theemeraldresort.com>

If you have not attended the Annual Weekend and Trade show in many years, well then this is the year you won't want to miss out on all the fun and camaraderie. There will be lots of giveaways, raffles, great entertainment and laughs with friends you may not have seen in years!

All rooms and booths are on a first come first serve basis. If you would like a specific room or booth location **DO NOT** delay in getting you reservations in early.

The last trade show was a great success thanks to the many MLA members, vendors and show attendees who are dedicated to the fishing industry. The Annual Weekend Committee continues to work hard to bring you new vendors to keep you up to date with all the newest gadgets and equipment in the industry.

If you are interested in helping at the show, please call the office and we will be more than happy to have your help. Let's make this 2024 Annual Weekend one to remember!

See you in March,
 Annual Weekend Committee



EXHIBITOR RESERVATION

Annual Weekend & Industry Trade Show 2024

March 21-24, 2024

Massachusetts Lobstermen's Association
 8 Otis Place, Scituate, MA 02066-1323
 Tel (781) 545-6984
 Tracey.Abboud@lobstermen.com

Annual Weekend & Trade Show 2024
 March 21 - March 24th 2024 (set up on March 21)
 Emerald Resort and Conference Center of Hyannis
 35 Scudder Ave, Hyannis, MA 02601

Exhibitor Booth Reservation-2024

Booth's include a 6' covered table & 2 chairs

- () 1 Booth \$750 _____
- () 2 Booths \$1050 _____
- () 3 Booths \$1350 _____
- () Electricity \$95 _____
- () Lift for Engine \$200 _____

Total Enclosed \$ _____

Set-up begins at 9:00 AM on Thursday (March 21) and must be completely removed by 1:00 PM on Sunday unless other arrangements have been made in advance.

ALL BOOTHS MUST REMAIN INTACT AND YOU MUST BE AT YOUR BOOTH BY 8:00 AM Sunday to qualify for the vendor raffle. 4 CASH PRIZES THE BOOTH MAY NOT BE DISMANTLED UNTIL 10:00 AM SUN. (March 24th)

Company Name: _____

Address: _____

City, State, Zip Code: _____

Daytime Tel: (_____) _____ Fax: (_____) _____

Person in Charge of Booth: _____ E-mail: _____

Primary Product or Service: _____

(If you are having an engine delivered PLEASE call and schedule a delivery time with Tracey Abboud 781-545-6984 xt. 2 —Thank you)

Special Requests or Needs: _____

Payment Info: () MasterCard () Visa () Check (Payable to MLA)

Name on card: _____

Card # _____

3 numbers on back of card: _____ Card Exp Date _____

(You may call this number in)

Signature: _____



EXTRA MEAL TICKETS

Annual Weekend & Industry Trade Show 2024

March 21-24, 2024

MLA Annual Weekend & Lobster Trade Show 2024
 EMERALD RESORT/IRISH VILLAGE, HYANNIS, MA

Order Form for Extra Meal Tickets

Day/Time	Description	Price Per Person	Number Requested	Total Price
3/22/24 Friday Evening Buffet 6:30 pm – 7:45 pm Entertainment TBD 7:45pm to 9:00pm	<u>Buffet Dinner</u> Roasted Tomato Soup Mixed Garden Greens 2 choices of dressings Roasted Chicken with Cornbread and Dried Fruit Stuffing Braised Beef Short Ribs Chefs Selection of Starch and Seasonal Vegetables White Chocolate Bread Pudding Coffee and Tea	\$50.00		
3/23/2024 Saturday Evening Dinner 6:30 pm Dinner Award Ceremony 8:00pm Entertainment TBD 9:00pm – 11:00pm Please choose Entrée	<u>Banquet Dinner</u> New England Clam Chowder Caesar Salad Choice of Seafood Medley consisting of Fish, Scallops & Shrimp or Prime Rib of Beef Warm Rolls Chef's choice of Starch, Vegetable, Dessert, Coffee and Tea (Please Choose Entrée) Seafood Medley consisting of Fish, Scallops & Shrimp - Prime Rib of Beef-	\$65.00		
Total Amount Enclosed: \$				

Name: _____ Tel : _____
 Address: _____

Visa Master Card Check payable to MLA

Name on Card _____
 Card Number: _____ Exp Date: _____
 Last 3 numbers on back of card: You may call this number in: _____
 Signature: _____ Today's Date: _____

Mail this form to:
 Massachusetts Lobstermen's Association
 8 Otis Place, Scituate, MA 02066
 Tel. (781) 545-6984



HOTEL RESERVATION FORM

Annual Weekend & Industry Trade Show 2024

March 21-24, 2024



EMERALD
RESORT

35 Scudder Avenue
Hyannis, MA 02601
Main Phone: 508-775-7775

**Massachusetts Lobstermen's Association
Annual Weekend and Trade Show 2024**

HOTEL RESERVATION FORM

Thursday, March 21, 2024 - Sunday, March 24, 2024

NAME(S) _____

ARRIVAL DATE: _____ DEPARTURE DATE: _____

ADDRESS: _____

CITY: _____ STATE: _____ ZIP CODE: _____

DAY TELEPHONE: _____ FAX: _____

E-MAIL ADDRESS (REQUIRED): _____

CREDIT CARD TYPE: _____ CREDIT CARD NUMBER: _____

EXPIRATION DATE: _____ SIGNATURE: _____

Hotel & Meal Package Options						
Check Choice	Package Type	Nights	Cost Per Package	Friday Evening Buffet	Saturday Evening Banquet Select One per Adult	
					Prime Rib	Seafood Medley consisting of Fish, Scallops & Shrimp
	1 Night Package, 1 Adult	Friday Only	\$160.89	Included	Not Included	Not Included
	1 Night Package, 2 Adults	Friday Only	\$199.90	Included	Not Included	Not Included
	1 Night Package, 3 Adults	Friday Only	\$250.35	Included	Not Included	Not Included
	1 Night Package, 1 Adult	Saturday Only	\$198.89	Not Included		
	1 Night Package, 2 Adults	Saturday Only	\$275.88	Not Included		
	1 Night Package, 3 Adults	Saturday Only	\$364.33	Not Included		
	2 Night Package, 1 Adult	Fri & Sat	\$359.78	Included		
	2 Night Package, 2 Adults	Fri & Sat	\$475.78	Included		
	2 Night Package, 3 Adults	Fri & Sat	\$614.68	Included		
	3 Night Package, 1 Adult	Thurs, Fri & Sat	\$481.68	Included		
	3 Night Package, 2 Adults	Thurs, Fri & Sat	\$597.69	Included		
	3 Night Package, 3 Adults	Thurs, Fri & Sat	\$748.05	Included		



HOTEL RESERVATION FORM

Annual Weekend & Industry Trade Show 2024

March 21-24, 2024

Package prices are inclusive of all taxes, gratuities and service fees.

Additional Hotel Options			
Check One	Additional Nights	Indicate Dates/Number of Adults	Cost
	Hotel Only. No meals included. Rate is per night for 1 or 2 adults. Rate is inclusive of tax.		\$135.05 Per Night

RESERVATION POLICIES

Cutoff Date: All reservations for guestrooms must be made by Thursday, March 7, 2024. After this date, we cannot guarantee the availability of guestrooms or the group rate.

Meal Tickets and Choices: All meal choices for the Saturday night banquet must be made prior to Thursday, March 7, 2024. If meal selection is not made by this date, we cannot guarantee your preferred meal choice. *Meal selections and number of guests in the package may not be adjusted within 10 days of arrival.*

Deposit: We require a deposit of \$100.00 at the time the reservation is made. If the deposit is by credit card, we will charge the deposit in advance when the Reservation Form is received.

Cancellation Policy: If an individual reservation is cancelled (7) seven days or more prior to arrival the deposit is refunded less a \$15.00 service charge. If an individual reservation is cancelled (6) six days or less or the guest does not arrive on the specified dates, the reservation is cancelled for all nights and the deposit will be forfeited. The remaining nights on the reservation will also be cancelled and are not automatically reinstated.

Confirmation: A confirmation email will be sent to you directly from the Emerald Resort/Irish Village.

CHECK-IN TIME AFTER 3:00 PM - CHECK-OUT TIME BY 11:00 AM

Please Fax, Email or Mail completed form to our Reservations Department (1 form per room)

Updated Fax Number: 508-778-6910

Email: stay@theemeraldresort.com

Mail: Emerald Resort / Irish Village 35 Scudder Avenue, Hyannis, MA 02601

Please make checks payable to the Emerald Resort

This form must be received prior to March 7, 2024. Phone or online reservations will not be accepted. Any changes to your reservation must be made by submitting a revised form. Please note change and mark form as "REVISED" to avoid duplicate reservations.

WE DELIVER FRESH LOBSTER BAIT

INCLUDING:

HERRING

POGIES

MACKEREL

RED FISH

SKINS

BLUEFISH

CHUM

SALMON
HEADS



FRESH, SALTED, AND QUICK FROZEN BAIT

Barrel Head Bait

WE SELL SALT!

For More Information: To Place An Order:

Mark Flight
mark@barrelheadbait.com

The Bait Line:
857-200-2129
Or Fax:
617-561-8471



MASSACHUSETTS DIVISION OF MARINE FISHERIES

2022 LOBSTER TABLES

TABLE 1. Permit Information for the Massachusetts lobster fishery, 2015-2022¹

	2015	2016	2017	2018	2019	2020	2021	2022
Coastal Permits								
Issued	1,139	1,116	1,088	1,081	1,066	1,047	1,031	1,011
Fished	704	704	714	712	698	661	663	654
Did Not Fish	350	317	308	309	315	319	296	283
Incomplete	14	15	8	10	11	11	16	9
Not Reporting	71	82	58	50	42	56	56	65
Offshore Permits								
Issued	159	154	171	156	150	137	133	131
Fished	63	66	66	73	70	65	59	52
Did Not Fish	10	8	9	7	7	6	9	9
Incomplete	1	2	1	0	2	2	2	0
Not Reporting	85	78	95	74	71	64	63	70
Offshore Non-Trap Permits								
Issued	235	242	236	236	242	246	231	237
Fished	90	90	83	75	70	80	74	72
Did Not Fish	9	13	10	8	8	8	6	6
Incomplete	2	0	3	3	1	1	0	0
Not Reporting	134	139	140	150	163	157	151	159
Seasonal (Student) Permits								
Issued	86	88	96	100	104	102	101	105
Fished	44	51	46	52	46	58	54	50
Did Not Fish	29	17	31	23	33	33	26	32
Incomplete	2	2	1	1	2	0	1	1
Not Reporting	11	18	18	24	23	11	20	22
Recreational Permits²								
Issued	7,046	6,535	6,427	6,118	6,481	6,244	5,771	5,555
Fished	4,086	3,782	3,599	3,412	3,353	3,343	3,026	2,844
Did Not Fish	1,203	1,125	1,099	1,107	1,032	1,104	n/a	n/a
Not Reporting	1,757	1,628	1,729	1,599	2,096	1,797	n/a	n/a

Data Sources: ¹ Trip-Level Reports (DMF and NMFS VTR data); ² Beginning in 2021, reporting methods for recreational harvest changed and it is no longer possible to differentiate between non-fishing activity, and non-reporting.

TABLE 3. Massachusetts Commercial Lobster Landings, Traps Fished and Estimated Value for 2016-2022

Total Landings	18,467,688	17,218,843	18,439,451	17,866,857	16,797,873	17,029,592	15,499,957
Total Estimated Value	\$82,366,920	\$81,170,506	\$88,821,161	\$95,491,339	\$78,307,441	\$125,383,208	\$83,030,006
Total Traps Fished	397,822	403,339	398,148	380,402	369,029	361,481	350,088
Average Price (\$) / Lb	\$4.46	\$4.71	\$4.82	\$5.54	\$4.66	\$7.36	\$5.36
Ave. Lbs. Trap-Haul	1.5340	1.4922	1.6931	1.4850	1.5697	1.6210	1.4037
Ave. Lbs. /Trap	44.44	40.57	44.35	44.59	43.29	44.57	44.27
Territorial (State Waters)							
Landings	11,083,697	10,226,598	10,753,269	10,271,565	9,039,659	9,573,878	8,303,038
Estimated Value	\$49,433,905	\$48,208,705	\$51,797,522	\$54,897,482	\$42,140,607	\$70,489,275	\$44,477,625
Trap Landings	10,980,152	10,125,850	10,630,391	10,167,760	8,997,134	9,521,291	8,279,102
Traps Fished	290,233	292,928	290,279	274,322	259,546	258,626	244,947
Non-Trap Landings	103,545	100,748	122,879	103,895	42,525	52,588	23,936
Non Territorial (Federal Waters)							
Landings	7,383,992	6,992,245	7,686,181	7,595,292	7,758,214	7,455,713	7,196,919
Estimated Value	\$32,933,015	\$32,961,801	\$37,023,639	\$40,593,857	\$36,166,834	\$54,893,933	\$38,552,381
Trap Landings	6,699,237	6,238,456	7,029,161	6,892,240	6,976,830	6,589,814	6,358,003
Traps Fished	107,589	110,411	107,869	106,080	109,483	102,855	105,141
Non-Trap Landings	684,755	753,789	657,020	703,052	781,384	865,899	838,916

Data Sources: Trip-Level Reports (DMF and NMFS VTR data), SAFIS Dealer Database

TABLE 4. Number of active commercial lobstermen and lobster landings, not including seasonal permits by homeport for 2022

Homeport data taken from vessel information on permit applications. In cases where no vessel or homeport was specified, the primary port of landing was used. Catch data encompasses all reported landings, regardless of gear type, while effort data represents only trap effort. Shaded areas denote towns which rank in the top 10 for either number of fishermen, total catch, or total effort. Some cities and towns are combined to protect the confidential nature of the data.

City / Town	Fishermen		Catch (Pounds)					Effort ¹		
	Number	Rank	Territorial	Non-Territorial	Total	Percent	Rank	Traps	Percent	Rank
Barnstable-Hyannis	7	21	35,005	0	35,005	0.23%	34	1,910	0.55%	34
Beverly	20	14	493,007	301,186	794,193	5.12%	6	11,865	3.39%	10
Boston	32	7	311,181	147,298	458,479	2.96%	11	9,688	2.77%	12
Chatham	27	9	125,603	385,779	511,382	3.30%	10	9,412	2.69%	13
Cohasset	23	12	237,127	80,682	317,809	2.05%	14	8,727	2.49%	14
Cuttyhunk-Falmouth ²	4	24	*	*	15,981	0.10%	37	522	0.15%	38
Danvers-Salem	10	20	*	*	209,596	1.35%	19	3,910	1.12%	23
Dartmouth-Westport	14	18	23,366	262,196	285,562	1.84%	15	6,060	1.73%	16
Dennis-Harwich	17	15	28,474	100,481	128,955	0.83%	24	5,451	1.56%	20
Duxbury-Kingston	5	23	27,118	0	27,118	0.17%	35	1,415	0.40%	36
Eastham	7	21	132,894	0	132,894	0.86%	22	2,263	0.65%	32
Essex	3	25	3,802	0	3,802	0.02%	40	268	0.08%	40
Fairhaven	10	20	*	*	73,218	0.47%	28	3,005	0.86%	26
Gloucester	130	1	1,220,447	2,234,406	3,454,853	22.29%	1	61,755	17.64%	1
Hingham	5	23	*	*	104,241	0.67%	26	2,870	0.82%	28
Hull	21	13	282,208	100,694	382,902	2.47%	13	10,322	2.95%	11
Ipswich	5	23	4,677	0	4,677	0.03%	39	417	0.12%	39
Islands ³	17	15	20,643	41,235	61,878	0.40%	32	2,949	0.84%	27
Manchester	17	15	*	*	137,051	0.88%	21	5,624	1.61%	18
Marblehead	43	4	614,799	87,897	702,696	4.53%	7	20,293	5.80%	4
Marion-Mattapoisett	7	21	*	*	37,224	0.24%	33	2,410	0.69%	29
Marshfield	48	3	628,929	366,800	995,729	6.42%	4	27,062	7.73%	2
Nahant	15	17	250,782	0	250,782	1.62%	18	5,579	1.59%	19
New Bedford	41	5	27,564	1,378,131	1,405,695	9.07%	2	18,658	5.33%	6
Newburyport	6	22	47,414	19,855	67,269	0.43%	29	2,267	0.65%	31
Orleans	5	23	62,115	0	62,115	0.40%	31	2,336	0.67%	30
Out of State	24	11	*	*	252,717	1.63%	17	5,318	1.52%	21
Plymouth	53	2	718,749	88,022	806,771	5.20%	5	26,668	7.62%	3
Provincetown	30	8	386,862	181,387	568,249	3.67%	8	16,084	4.59%	7
Quincy	3	25	10,680	0	10,680	0.07%	38	656	0.19%	37
Revere-Winthrop	10	20	83,447	0	83,447	0.54%	27	3,374	0.96%	25
Rockport	53	2	813,308	512,992	1,326,299	8.56%	3	20,199	5.77%	5
Salisbury	5	23	59,239	51,574	110,812	0.71%	25	1,738	0.50%	35
Sandwich	26	10	228,509	216,367	444,876	2.87%	12	13,155	3.76%	8
Saugus	11	19	*	*	131,929	0.85%	23	5,967	1.70%	17
Scituate	37	6	341,834	218,729	560,562	3.62%	9	12,363	3.53%	9
Swampscott	10	20	198,843	0	198,843	1.28%	20	4,861	1.39%	22
Truro-Wellfleet	16	16	188,380	68,459	256,839	1.66%	16	7,132	2.04%	15
Weymouth	6	22	*	*	65,983	0.43%	30	3,515	1.00%	24
Yarmouth	4	24	20,846	0	20,846	0.13%	36	2,020	0.58%	33

¹The number of "Traps" for each city/town represents the sum of each individual's maximum traps fished for the year; ²The village of Woods Hole is included in Falmouth ³The town of Chilmark, Edgartown, Menemsha, Nantucket, and Vineyard Haven are all included under "Islands"; *Confidential Data



HERCULES
SLR (US) Inc.
MARINE • FISHING GEAR • SAFETY

44 South Street, New Bedford, MA 02740
Phone: 508-993-0010 Fax: 508-993-9005
Securing - Lifting - Rigging
82 MacArthur Dr. New Bedford, MA 02740
Phone: 508-992-9519 Fax: 508-992-9419

JohnReardon@Hercules-SLR-US.com



www.Hercules-SLR-US.com

USCG Safety Inspection Station #327

Commercial Fishing-Marine Safety-Rigging

- ❖ Marine Hardware
- ❖ Cotesi - Netting, Leaded/Sink Rope
- ❖ Stormline & Climate Technical-Foul Weather Gear
- ❖ Buoys & Floats
- ❖ Lobster Bands
- ❖ PFD's, Vests, Float Coats
- ❖ Fish Totes
- ❖ Insulated Tubs
- ❖ Cordage & Twine
- ❖ Mooring Equipment
- ❖ Boarding Ladders
- ❖ Polysteel Rope- Esterpro Sinking, Hydropro
- ❖ Leadline
- ❖ Wire Rope - FC Galv, IWRC, Dyform
- ❖ HiFlyers 12', 14' & 15' XHD
- ❖ Golf & Batting Cage Netting



Inflatable PFD's



Life Raft Sales

- ❖ Revere
 - ❖ Elliot
 - ❖ Survitec
 - ❖ Switlik
- All brands accepted for service



ACR Electronics
Sales & Service
for your E.P.I.R.B.



Fenders & Buoys-All Colors



Boots from Honeywell Safety

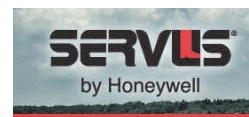

On-Board Vessel Inspections & Safety Drills

Call our USCG Certified Drill Conductors:

Rodney Avila 508-889-0401

Ted Williams 508-264-5779



Imperial Survival Suits
Sales & Annual Inspections
Done in house



Legal Defense Fund Updates

The Massachusetts Lobstermen's Association (MLA) Legal Defense Fund (LDF) needs your support now more than ever. This dedicated fund is for the purpose of defending the Massachusetts commercial lobster fishermen from legal and fisheries management actions that could seriously impact our commercial lobstermen's ability to conduct their businesses and earn a living.

Currently, the MLA is actively engaged in three separate lawsuits that could have negative impacts on the commercial lobster industry and is working with multiple lawyers in Washington D.C. and here in the Commonwealth to fight for you and your industry.

UPDATE 11/21/2023 (Washington D.C.) Case 1:18-cv-00112-JEB - CENTER FOR BIOLOGICAL DIVERSITY et al v. ROSS et al.

On May 16, 2023, NMFS moved to dismiss Judge Boasberg's Order requiring it to create a new Biological Opinion by the end of 2024 and dismissing the remainder of the NGOs claims. NMFS's basis for doing this was claiming that the Consolidated Appropriations Act doesn't require a new Biological Opinion until 2028, making the decision moot. This is an almost identical argument to the one NMFS raised to the D.C. Circuit, which has not yet ruled on the motion to dismiss.

Given this, we asked the Court to stay briefing on the motion to dismiss until the D. C. Circuit has ruled.

The Court granted out motion to stay, delaying briefing until after the D.C. Circuit ruled. However, in the ruling, the Court said its order requiring a new Biological Opinion by December 2024 was no longer operative, giving clear relief to the lobstermen.

Now that the D.C. Circuit has issued its mandate, briefing has resumed on the motion to dismiss. The NGOs have brought a motion asking the district court to delay enforcing the mandate.

To prevail on the motion to stay, the NGOs needed to not only convince the Court the moving party's need for a stay — that is, the harm to the moving party if a stay does not issue; and (3) whether a stay would promote efficient use of the Court's resources.

The Court was unsympathetic to any of these claims. First, it rightly noted that the NGOs mis-

cited case law (a nice way of saying lied) to show he could ignore the D.C. Circuit. He slapped that down and said he cannot ignore the D.C. Circuit, so the issue is done. But then he went further, addressing each stay element.

He decided that the government would be harmed by delays in implementing regulations, and the lobstermen would be harmed by delays in certainty. He determined that the NGOs do not need a stay because it won't affect their other claims. We disagree with that as we think this moots their claims but we don't read this as him saying he's not going to moot their claims, which we have also moved for. Finally, he determined it would not be efficient use of resources.

Overall, this was a pretty definitive rejection of the NGOs theories and to us shows that Judge Boasberg is rightly skeptical of the NGOs claims in light of the D.C. Circuit ruling.

Briefing on the motions to dismiss the NGOs claims based on mootness is ongoing and we do not anticipate a ruling before the end of the year.

UPDATE 11/21/2023 (N.D. California.) Case No. 5:23-cv-04994-BLF; Sawyer, et al. v. Monterey Bay Aquarium, et al.

In the ongoing fight against the Monterey Bay Aquarium and its defamatory statements, our case was recently transferred to the Northern District of California. Our case has since been assigned to Judge Beth Labson Freeman, and our case management conference, which will set the timeline for the remainder of the litigation, is currently set for February 29, 2024.

In the interim, the Aquarium has filed a motion to strike our Complaint. This would function essentially as a motion to dismiss, and would end the suit. The basis for their argument is California Civil Procedure Code Section 425.16, which is California's anti-SLAPP statute. For those who are unfamiliar, anti-SLAPP (Strategic Lawsuits Against Public Participation) statutes are a mechanism for defendants to seek dismissal of lawsuits that they allege attempt to infringe upon their First Amendment rights. Of course, it is well-settled law that defamation and libel are *not* examples of protected speech under the First Amendment. Our argument has always been that the Aquarium is engaging in intellectually dishonest attempts to sway public opinion by twisting the science it claims supports its position: specifically, that despite there being no evidence that Massachu-

setts fisheries are the cause of *any* whale deaths, *all* lobster fisheries, including the Massachusetts fisheries, are somehow unsustainable.

This move does not come as a surprise, and we will ask the Court to deny the motion. The Aquarium specifically acknowledges in its motion that "MBAF . . . expressly acknowledg[ed] when it lack[ed] certain evidence to support its opinion that lobster fisheries endanger right whales." Note the use of the word "opinion" here — opinions are generally protectable by the First Amendment, which is why the Aquarium has used and likely will continue to use the word in an attempt to convince the Court to see its press release not as an affirmative statement of fact from an organization that calls itself a "leader" in science and conservation, but as nothing more than an opinion protectable by the First Amendment. Should we be unable to convince the Court not to strike our Complaint as is, however, the pleading standards are on our side: courts are widely in favor of granting plaintiffs leave to amend their complaint in the face of an anti-SLAPP motion to strike. Should it come to that, we have strategies in the pipeline that we can deploy to continue the fight to defend the Massachusetts lobster fisheries. Stay tuned for more, and don't forget to thank your named Plaintiffs, Arthur Sawyer, Jarrett Drake, Eric Meschino, and Bill Souza, for their ongoing efforts in this fight to protect all Massachusetts lobstermen from unscientific libel and slander.

UPDATE 11/21/2023 NMFS's Proposed Rule to Permanently Close the Wedge

Last year NMFS illegally extended the 2022 Wedge Closure to close the Wedge from February through April 2023. We challenged this decision in Court and the Court agreed we were right on the law, but ultimately decided not to stop it because we could not show irreparable harm.

NMFS is now at it again, attempting to convert its illegal 2023 Wedge Closure into a Permanent Final Rule. We are preparing a robust comment to the proposed final regulation that will explain to NMFS why its proposed final rule is illegal.

If NMFS intends to move forward with its illegal action, we will proceed with litigation against it.

If you are a Massachusetts lobsterman interested in joining the Massachusetts class action, please contact the MLA.

¹ <https://www.montereybayaquarium.org/stories/julie-packard-wendy-schmidt-talk-ocean-conservation>



Donate to the MLA Legal Defense Fund to
“Band the Bite” TODAY!

Help us fill the lobster crate and help relieve
the **“PINCH”** of defending commercial lobstermen!

Let's fill the lobster crate TODAY!

Every \$25 dollars donated puts another lobster in the lobster crate!!

There are several ways to make a donation

MLA website: www.lobstermen.com Legal Defense Fund Donation

Paypal: Legal Defense Fund Donation

Mail or drop off a check:

MLA, 8 Otis Place, Scituate, MA 02066

Call the MLA : 781-545-6984 xt2

Use your camera on your phone to Scan the QR Code

***THANK YOU for YOUR
CONTINUED SUPPORT!***





DONATE TODAY!

to the Massachusetts
Lobstermen's Association

LEGAL DEFENSE FUND

DECEMBER 2023 SUPPORTERS

Richard Aprans
Jeffrey Bartlett
Michael Bartlett
Kevin Beaton
Dana Campbell
Johsua Carnevale
Edward Desrosier
Scott Draper
Peter Fadden
Mike Goodwin
Geordie King
Frank Kristy
George Landers
Eric Lorentzen
Donald Lowe
David Malloes
Dean Morey
Tucker Patterson
Paul Quintal
Michael Rego
Mike Richardson
Neil Rossman
Therese Sauvageau
Mark Sawyer
Daniel Shannon
Edward Smith
Jack Snow
Scott Swicker
Paul Theriault
Scott Torrey
Michael Tufts

**THANK YOU FOR YOUR
CONTINUED SUPPORT!**

LDF Updates

FROM PAGE 37

The commercial lobstermen's businesses are at stake as well as the thousands of jobs and shore side businesses that depend upon the continued success of the commercial lobster industry. The commercial lobstermen in Massachusetts are NOT to the problem and have done everything asked of them by National Marine Fisheries Service and have been working under the strictest conservation rules for the right whales anywhere in the world since 2014. Yet here we are, still fighting these lawsuits to keep the Massachusetts commercial lobstermen fishing.

The Massachusetts Lobstermen's Association has been actively involved in these lawsuits since 2018 and we need your generous support today to continue our fight to keep the commercial lobstermen fishing. As we all know, any legal action costs lots of money and over

the last 5 years the Massachusetts Lobstermen's Association Legal Defense Fund has spent over \$300,000 fighting these legal battles. These are real threats to the historic and iconic commercial lobster industry, and we are doing everything to keep Massachusetts commercial lobstermen fishing.

WHERE TO MAKE DONATIONS

Any contribution you can afford to make to the Legal Defense Fund is greatly appreciated.

Donate by mail:

MLA LDF
8 Otis Place
Scituate, MA 02066

Donate online:

www.lobstermen.com

- In the Members section, select Dues/Donate.

Thank you for your continued support!

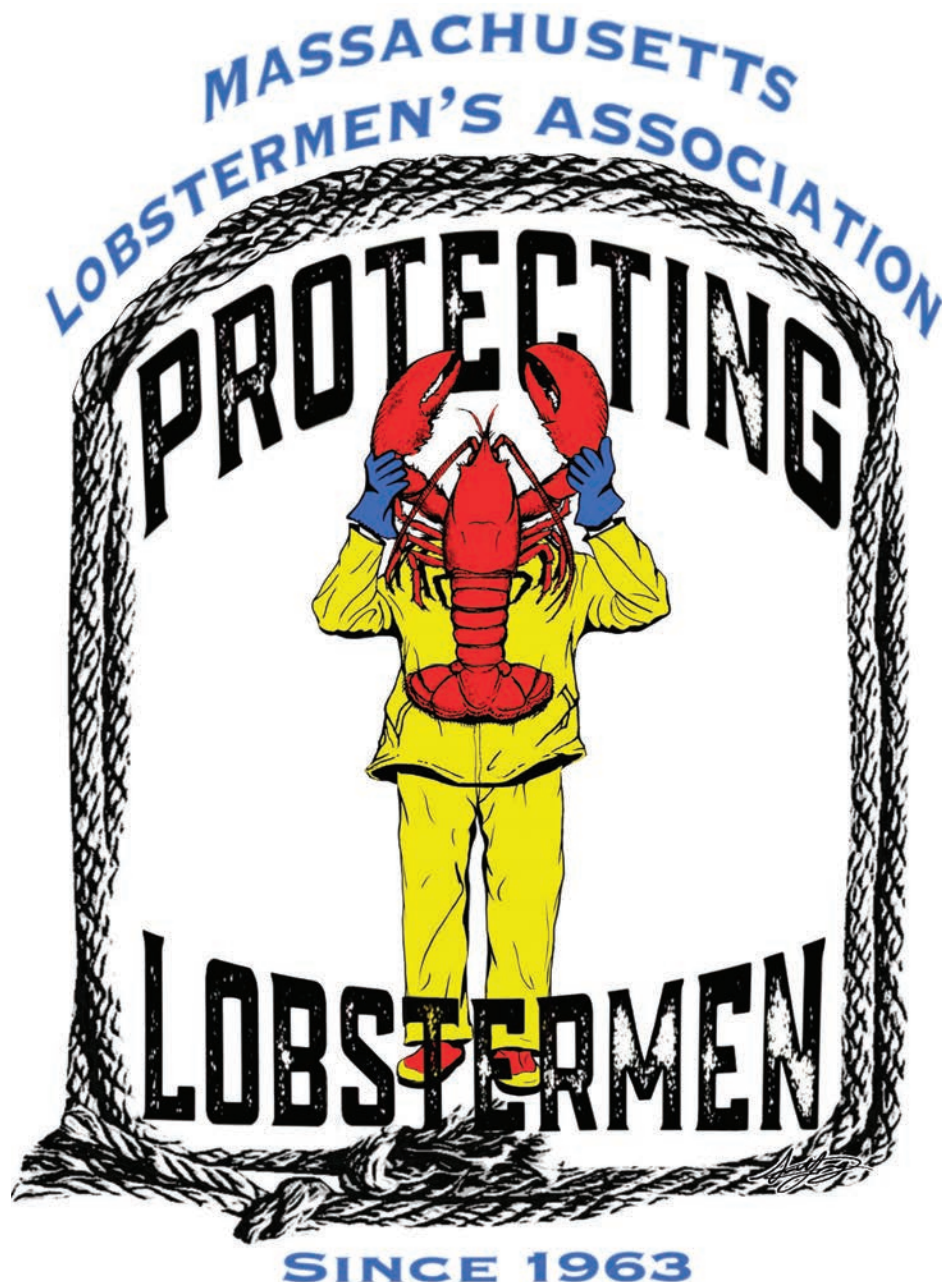

Ketcham Store Specials

Proflex Rope! All sizes, sink or float, 10% off on 10 coils or more

while supplies last



Baskets and Totes

- Gray Box with Folding Lid \$55
- Round Basket (all colors) \$20
- Black Basket \$12
- Gray Basket \$12
- Milk Crate \$11



111 Myrtle Street
New Bedford, MA 02740
508.997.4787



www.ketchamsupply.com
info@ketchamsupply.com
@ketchamtraps

MLA Classifieds

Classified ads are a free benefit to MLA Members and Non-members are a flat \$25.00. Ads run for 5 months & will be automatically deleted unless you call the MLA office to renew. **781-545-6984** or email ads to: tracey.abboud@lobstermen.com
*All ads are subject to review prior to placement

AD #1 (5/23) **FOR SALE** – 55' wooden offshore lobster boat w/2 fresh 671s. Just off railway. Boat is turnkey. In very good condition. Full electronics & safety gear. Asking 70k OBO. Also have NJ conch license & conch pots could make deal w/ purchase of boat. Boat & gear ready to fish. Also have Virginia Commercial Registration License. Call Joe @ 609- 233-4255

AD#2 (9/23) **FOR SALE** – Trap Trailer 6x12 can hold approx. 50-3 footers. Good shape. \$1,200.00 Call Ben 978-578-8882

AD#3 (10/23) **FOR SALE** – Hydraulic Components, parts, and service. Pumps, Motors, Valves and Accessories. Hydraulic Hoses are made while you wait. Great Prices—Same day service (in many cases)—Wide selection of in-stock items. Rebuilt items are occasionally available. ROSE MARINE, Gloucester, MA 877-283-3334

AD#4 (8/23) **FOR SALE** – 400 Lobster traps 36x22 1/2 x 15 New to 5 years old \$60-100 each Call 978-774-4074

AD#5 (10/23) **FOR SALE** – KC Trap & Mesh—Traps-Heads-Finished Kits. Call for more information. 774-280-6638

AD#6 (10/23) **FOR SALE** – 1981 50 Ft., Jersey Boat- Twin disc 507- Detroit 671- Needs wiring & electronics. BRO \$25,000.00 Call for more info-781-834-6733

AD#7 (10/23) **FOR SALE** – Bruce Atkinson Novi 38ft 1984. Rebuilt John Deere 6081 375 hp/1500 hrs. by Downeast Diesel. 2 steering stations, 14" ss pot hauler, ss davit, 295 Furuno color machine & tons more. Very well maintained boat. Available in Gloucester. Reach out with ANY question. Chris 781-424-6946

AD#8 (8/23) **FOR SALE – SIZE CORRECTION** – Warp—Used & some new, mostly knot free. 76 lbs. 5/16, 33 lbs. 3/8 \$99 takes all 508-269-1406 Plymouth.

AD#9 (10/23) **FOR SALE** – In Boston. 60 new yellow cavatorta wire 43.5 x 22.5 x15 lobster traps. Kitchen haul, double parlor hand knit head in rear, 10 gauges ends, bridges & front corner braces. 12-gauge body, side brace, skid plate & side chaffing pieces. Has plastic coated steel runners, plastic corners & plastic runner bumpers. These are quality made traps that you will absolutely love to haul! \$182 each. Call Ed 617-680 -4096

AD#10 (12/23) **FOR SALE** – 500+ lobster traps w/line & buoys \$35.00 each, located in Scituate. Call 978-815-1734

AD#11 (10/23) **FOR SALE** – Turnkey Outer Cape Lobster Business: 1981 31ft. BHM Volvo 63P—370 HP, 2 1/2:1 Twin Disc, spare wheels, many spare engine parts. OC State permit w/270 tags+ 10%, many endorsements, 400+ traps, ground lines, end lines, flags, Go-Deeps, 200 totes, lids, + trap building tools & equip-

ment. Boat also setup for Dogfish & Mackerel w/all gear, 8x16 traor trailer, 5'x7' walk in bait cooler, 6000# mooring in Chatham Harbor, fiberglass skiff with 10HP Suzuki 4 stroke & trailer. \$200k Or BRO Steve 978-257-1062

AD#12 (10/23) **FOR SALE** – 31 ft., BHM Lobster boat. 300 hp- John Deere, 2-VHF radios, chart plotter, Furuno fish finder, built in live tank, radar, 3 swivel rod holders. \$65,000.00 Call 508-280-3038

AD#13 (6/23) **FOR SALE** – 200 used traps 13 1/2 x 21 1/2 x 39" \$25. per trap -401-635-4371

AD#14 (8/23) **FOR SALE** – 1980 Bob Rich 40 wooden lobster boat. 471 Detroit diesel, twin disc gear, hydro-slave pot hauler w/diverter valve for other fisheries. Two 75-gal fuel tanks (fiberglass) under deck, full cabin, GPS, Furuno depth sounder, VHF radio, MA coastal Area 1 lobster permit, 800 trap. Federal Area 1 lobster permit w/endorsements (groundfish/dogfish) 800 pot limit. 140 wire lobster traps, some never used (brand new) 60-70 buoy's, extra ropes, safety equipment, sea anchor, 12 fiberglass skiff misc; lobster related equipment, spare propeller (never used) trap related repair equipment. \$65,000. firm. Bill @ 781-834-7418

AD#15 (12/23) **FOR SALE** – 33 ft. lobster boat 1987 Novi/Scott 150 Ford engine. 600 traps N.H. lobster license 100+ traps, dingy, trap trailer, ropes & buoys. Boat has been out of the water for 3-years. Also, a mooring at Pierce Island. \$54,900.00 Call Douglas @ 603-566-3654

AD#16 (12/23) **FOR SALE** – 22' Sisu Lobster Boat W/150 HP Evinrude OB needs work. Has 12" Hydraulic hauler. Runs off Honda Hydraulics. Power Pack needs work. Comes W/ bunk trailer. Asking \$8000. or B.O. Call Robert@ 5:00 p.m. 617-846-3714 or 617-650-3842

AD#17 (10/23) **FOR SALE** – Federal Area 1 Permit: Offers over \$35,000 will be considered. IHsea@aol.com 781-639-0001

AD#18 (10/23) **FOR SALE** – Airsep- air-cleaner 5 \$100.00 Joel @781-581-0324 or E-mail joel.w.marie@gmail.com

AD#19 (10/23) **FOR SALE** – 5" Superior hauling block-Aluminum construction with stainless sheave \$250. Joel @ 781-581- 0324 or E-mail joel.w.marie@gmail.com

AD#20 (10/23) **FOR SALE** – Spare new stainless sheave for 5" Superior block-\$150. Call Joel at 781-581-0324-E-mail joel.w.marie@gmail.com

AD#21 (6/23) **FOR SALE** – 1990 42 ft PEI lobster boat in excellent condition. Cummins 8.3L -6 CTA w/ ZF gear. 1700 hours on each. Electronics, safety gear, very well equipped.700 Brooks Trap Mill custom traps. 3/8 Everson ground line, & whale safe compliant end lines, Hi flyers & tide balls. State & federal licenses. As of June 1st, all gear in the water. Baited,

tagged & fishing. Buy today & fish tomorrow Complete package \$290,000. Will separate Boat \$210,000, traps \$75,000. state license \$30,000. & fed license \$40,000. Call 978-745-6182, leave message. Serious inquiries only

AD#22 (10/23) **FOR SALE** – In Boston. 60 new black cavatorta wire 43.5 x 22.5 x 15 lobster traps. Parlor haul, double parlor, shrimp mesh,10 gauge ends, bridges & front corner braces. 12 gauge body, side brace, kitchen brace, skid plate & side chaffing pieces. Has plastic coated steel runners, plastic corners & plastic runner bumpers. These are quality made traps that you will absolutely love to haul! \$180 each. Call Ed 617-680-4096

AD#23 (10/23) **REDUCED- FOR SALE** – Complete lobster business. Area 1 MA State license 800 trap allocation with long history. Dog & shellfish endorsement. 1987 Gummond 31' w/12' beam enclosed cabin w/ "bus" heater 12kts cruise w/20+top end Cummings re-manufactured "Diamond" version 370 HP with 3500 hours. 300+ traps w/ ropes & buoys. 14ft tender w/ 3yr old Suzuki 4s 15 hp w/electric start. GPS/bottom sounder, life jackets, fish totes, etc. Would like to sell as a package but will accept separate offers on boat, license & fishing gear. \$70,000. OBRO Call Bob- 508-224-1664 or e-mail @ roalward@comcast.net Pictures available.

AD#24 (9/23) **FOR SALE** – 1 24X24 Freeman Hatch. Used. In good condition. \$500.00 1 36 foot shear \$300.00 1 4' by 8' trailer \$200.00 Call Ted 401-842-8165.

AD#25 (10/23) **FOR SALE** – Lobster business peripherals: OCLMA permit for 645 tags, dingy, tank, freezer, mixture of wood & wire traps in excellent condition, totes, etc. Serious inquiries only: 774-313-6287 or joneSeven@aol.com

AD#26 (10/23) **FOR SALE** – Hook gear for sale 5 totes 125 hooks per tote all brand new.5 totes of used gear. Brand new Danforth anchors included. \$1000.00 Call 781-831-1609

AD#27 (6/23) **FOR SALE** – Lobster Business- 28.2ft boat, built in 1976 engine cat 3208, 265HP trans 2.1 twin disk fiberglass JC hull. Area 1 Coastal lobster permit 800 trap allocation, 700 3ft lobster traps with rope and buoys. 80,000. Joe at 978-239-5927

AD#28 (6/23) **FOR SALE – Price Reduction** – 36.5' Wayne Beal Lobster Boat. 3208 CAT 375 hp Turbo w/7600hrs. Motor was completely overhauled prior to 2022 fishing season. Furuno chart plotter, depth, radar & radio. 2nd Simrad below. Switlik life raft, survival suits & Epirb. Small galley w/sink insulated icebox & 2500-watt inverter for coffee. 4 bunks w/matresses. Working head. Pacer pump & separate washdown pump. Redundant spare equipment (all new in box), Inc. Pacer pump w/hydraulic hoses, belts, starter motor, 2 alternators, windshield wiper arms & motors, bilge pumps, deck hoses, etc. The boat is clean & in excellent, fish-

able condition. \$205,000.00 Traps & Permits available. Ben@ 978-578-8882

AD#29 (11/23) **FOR SALE** – 2-506 twin disc transmissions 4k for both- priced to sell. Call/text Elaine 339-832-2493

AD#30 (6/23) **FOR SALE** – 35' Novi, 1989 Atwood solid fiberglass hull, Cummins 6BT (~4,000hr since reman.), rigged for pot fishing, needs a lot of work – \$16k or best offer. Currently in dry dock on Cape Cod. Call 508-737-1052

AD#31 (9/23) **FOR SALE** – Gill Nets (10 assorted, some new or recent rehangs (Hercules). Gill net reel, 48" diameter, 42" width. Holds average 4 + panels (1200'). Excellent condition, chain drive, full hydraulics. Complete tub trawl system equipped with 10" hydraulic hauler for retrieving Tub Trawls mounted on net reel. "Jamestown" / Chatham gravity baiter (3-bushel size). Four totes set up with stainless magazine hook storage 125 hooks (500 total), 300 additional hooks storage system (four totes), fast and simple to use. Over half mile, set up for Cod, blue fish, Spiny Dog fish, or what have you. Loads of extra clips, gangions, boxes of Brand-new Mustad E-Z Baiter hooks. Two survival suits (like new 3 years old). Still mounted on boat, can demonstrate until mid-September. Located in Freeport, Long Island, New York. Hoping to get \$1500.00 – 2000.00. We can talk. Call or text Captain Rich Hunter. 347-836-5382, I will most likely get back to you after 6:00 pm that evening. Be glad to answer any questions.

AD#32 (7/23) **FOR SALE** – 2001 Sea Pride Lobster Boat w/2016 Evinrude E-tec 90hp 2 stroke w/ low hours (under 1000) well maintained & perfect running condition. Commercially fished last 2 years. Boat is ready to fish. New in 2021: Transom Deck & stringers 27 gal; gas tank under deck 2 bilge pumps & wash-down pump, Trap Table, Hydraulic Steering, hauling motor, Hauling block, Deck hatches, Scuppers. All hardware for EZ Loader trailer including u bolts, bunk slides, guideposts w/ trailer lights elevated, recently replaced winch, trailer jack & rewired w/new lights, 2 new tires 20mph @ 4600 rpm \$18,000 call/text Tony 774-239-1599

AD#33 (10/23) **FOR SALE** – 50ft., Jersey boat 2-671 Detroit engines-twin disc transmissions-wiring needs to be finished, frame upbuild for lobstering. 30k or best offer. For more info, call-text Elaine 339-832-2493

AD#34(12/23) **FOR SALE** – Area 1 Coastal lobster permit \$25,000.00 Call Pete @ 508-364-5980

AD35 (6/23) **FOR SALE** – 22' Sisu Lobster Boat w/150 HP Evinrude OB needs work - 12" hydraulics hauler runs off Honda hydraulics power pack, Comes w/ bunk trailer. Asking \$13,000.00 or B.O. Robert after 5:00 p.m. 617-846-3714 or 617-650-3842

AD#36 (7/23) **FOR SALE** – 120 Green & Yellow lobster traps 36x24x14 – Some hoop heads & some shark heads. In good shape. Call 508-951-6400

AD#37 (6/23) **HELP WANTED** – Stern-man inshore- 46' lobster boat -North River -Call Bob 508-510-7792

AD#38 (6/23) **FOR SALE** – 200 45 Friendship lobster traps 8-6 years old \$25.00 each Call 508-510-7792

AD#39 (6/23) **FOR SALE** – 32" – 4 blade Dyna Quad Prop-2 1/2" bore, left hand \$2,500.00 Call 508-510-7792

AD#40 (6/23) **FOR SALE** – 1-34" Hytorg prop 2 1/2" bore, left hand \$1,000.00 Call 508-510-7792

AD#41 (7/23) **FOR SALE** – 1982 34' Makou Mahogany built lobster boat built in Mattapoisett Ma. area. Was repowered about 10 years ago with a Cat 3208 210 hp natural. Approx 3600 hours. Hull and bottom in very good condition. No need to glass it. In the water and currently fishing. Older basic electronics. Located in Scituate Ma. Pictures can be seen on craigslist or some of the Facebook sites. \$12,500. No permits. Call or text 617-984-9965

AD#42 (7/23) **FOR SALE** – 400 36x21 1/2x15 good to brand new condition shrimp mesh ss bait spike \$60-\$135- 978 774 4074 for more info.

AD#43 (7/23) **FOR SALE** – Outer Cape Lobster Permit-511 trap allocation. \$150,000. Traps available will send pictures upon request, most are 1-3 years old. Call Eric @ 508-255-8526

AD#44 (8/23) **FOR SALE** – 2002 40 hp Johnson Outboard motor long shaft, tiller steering, trim/tilt Electric and manual start Extra parts and manuals Been in storage for past 3-4 yrs. \$1,500. Call 508-246-4009

AD#45 (8/23) **FOR SALE** – 1985 25ft., Privateer Lobster Boat. Fresh water cooled Mercruiser v8 engine-260 hp. Runs great-spare re-built engine. A IO spare re-built prop-hydraulics steering new in box. Re-built 4-wheel trailer. Gantry system to lift boat off trailer. Garmen chart plotter GPS Map Garmen depth sounder-fish finder. VHF radio. Engine has stainless steel heat exchanger. Stainless steel exhaust risers. 50-30" lobster pots ready to fish. 100 spare buoys 2- coils rope, 440-gal refrigerator lobster tank-platform scale for weighing. Ice chipper. 3- 28" scallop drags-system is ready to fish. X-actic polar box 48x44x36- 5-boat stands. 8' Pram- Many other items- Call between 4-7 p.m. \$20,000.00 508-979-0568

Ad#46 (10/23) **FOR SALE** – Complete business – 31' BHM, rebuilt engine and transmission 2021, New shaft and propeller, Area 1 State only lobster permit, 700 wire traps and all the rope, buoys and more. Sold as a complete package Asking \$100,000 or best reasonable offer. Call Steve at 508-224-6610



FOR SALE:

50ft., Jersey boat 2-671 Detroit engines-twin disc transmissions-wiring needs to be finished, frame upbuild for lobstering.

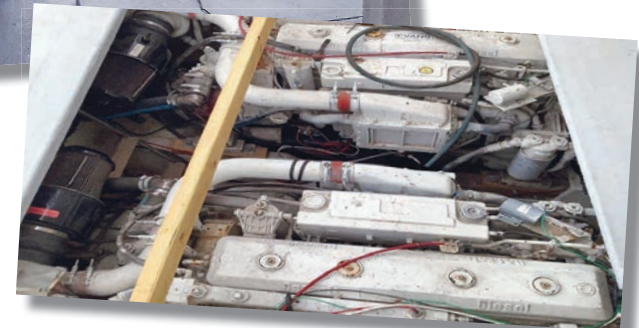

30k or best offer.

For more info, call-text

Elaine 339-832-2493

Make cleanup easy and fast.

Blast Away!

Onboard Pressure Washers
5.6 GPM @ 3,500 PSI

Our pressure washers come with everything you need, including 50' hose and wand with turbo nozzle.



Belt Driven

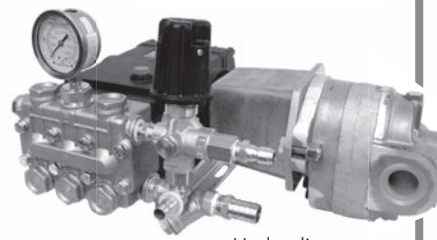

Hydraulic

Salt or Fresh Water

Coastal Hydraulics, Inc.

603-474-1914 • sales@coastalhyd.com

www.coastalhyd.com

28 Route 286. Seabrook. NH

CAT[®] Marine Power – C18

Available for new boat installations and repowers.



Ask us about our Customer Value Agreements (CVA)

C18 RATINGS

470/600@1800rpm A Rating

670/715@1800-2100rpm B/C rating

803@2100rpm D Rating

1015/1150@2300rpm - T4 Exempt ratings for light commercial

For Marine Engine Sales, contact Nick Fawle, Marine Market Manager.
603-484-5248 Nick_Fawle@miltoncat.com

AUTHORIZED MARINE DEALERS

Billings Diesel & Marine Service
Stonington, ME

Dennis' Welding & Marine
Beals, ME

Front Street Shipyard
Belfast, ME

Lyman Morse at Wafarer Marine Corporation
Camden, ME

Journey's End
Rockland, ME

Fairhaven Shipyard & Marina, Inc.
Fairhaven, MA

Guy Crudele Repair
Gloucester, MA

Sacchetti Marine and Industrial, LLC
Plymouth, MA

Windward Power Systems
Fairhaven, MA

DePaul Diesel Services, Inc.
Portsmouth, RI

Hinckley Yacht Service
Portsmouth, RI

Rhode Island Engine Company, Inc.
Narragansett, RI

Milton 

miltoncat.com

Massachusetts Lobstermen's Association
8 Otis Place
Scituate, MA 02066

PRSR STD
U.S. POSTAGE
PAID
Permit 137
New England Newspapers, Inc.



**Stock and Custom-Built Traps
Lobster and Specialty Traps
Aquaculture Supplies
Huge Inventory of Commercial
Fishing Supplies
Four Locations in Maine**



**BROOKSTRAPMILL.COM
(800) 426-4526**