

MASS. LOBSTERMEN'S ASSOCIATION, INC.

8 Otis Place

Scituate, MA 02066-1323

Tel (781) 545-6984 Fax (781) 545-7837

WEBSITE: www.lobstermen.com

E-MAIL: mia@lobstermen.com



United we Stand

ANNUAL WEEKEND & LOBSTER TRADE SHOW 2003
January 23-26, 2003

Forms Inside - MasterCard & VISA accepted



DECEMBER 2002

THE FOLLOWING COMPANIES, DEALERS, AND POUNDS ARE CURRENT, FULL \$100.00 SUPPORTING MEMBERS OF MLA. WE ENCOURAGE OUR MEMBERS TO PATRONIZE THEM WHENEVER POSSIBLE. THEIR SUPPORT HELPS US TO ACCOMPLISH OUR GOALS. IF YOUR COMPANY IS NOT LISTED IN THIS LISTING AND YOU WOULD LIKE IT TO BE, PLEASE CONTACT PEGGY DUPONT AT 781-545-6984

ALASKA DIESEL ELECTRIC - MIKE
MAYNARD - BURLINGTON, MA - 781-721-9200

CAPT. JOE & SONS INC. (DEALER) -
GLOUCESTER, MA 978-283-1454 -
www.wholesalelobster.com

G. DAVID BRIMMER & ASSOCIATES
PORTLAND, ME - 207-773-7600
www.877taxrelief.com

ALIVE & KICKING LOBSTER - LOUIS
MASTRANGELO - CAMBRIDGE, MA - 617-876-0451

CAPT. VINCE, INC. (DEALER) -
ANTHONY CIARAMETARO - GLOUCESTER,
MA 978-281-8860

GREEN HARBOR LOBSTER POUND -
FRED SCOTT - GREEN HARBOR, MA 781-834-4571

ANACKO CORDAGE CO. - WALTER
ANACKO, JAMESTOWN, RI - 401-423-0112

CHANNEL FISH CO., INC. - LOUIS
SILVESTRO - EAST BOSTON - 617-569-3200

GRUNDENS USA - MICHAEL JACKSON
POULSBO, WA - 360-779-4439
WWW.GRUNDENS.COM

BACK RIVER FISH MARKET - DONALD
MERRY - DUXBURY, MA - 617-934-9494

COASTAL HYDRAULICS - ED GUNDAL -
SEABROOK, NH - 603-474-1914

H&H PROPELLER SHOP - JOHN
PELLETIER - SALEM, MA - 978-744-3806

BAIT LADY - WAYNE BASSETT
SANDWICH, MA - 508-888-0096

COASTAL MARINE SUPPLY - JAMES
MADRUGA - GLOUCESTER - 978-283-5956

HAMILTON MARINE INC. - DAVID
NORMAN - SEARSPORT, ME - 207-548-6302 /
FAX 1-800-969-6352

BAR HARBOR LOBSTER - JEFF HAZELL -
ORLANDO, FL - 407-851-4001

COMMERCIAL MARINE ELECTRONICS
DANIEL HODGKINS - SCITUATE, MA -
CMEDAN@CONCENTRIC.NET - 781-545-7883

JAMES HOOK & CO. - ED HOOK JR.
(DEALER) - BOSTON, MA - 617-423-5500

BATTERIES, INC. - JOE TECZAR - SALEM,
MA - 508-744-4447

CUMMINS NORTHEAST - MEL MOLGARD
- DEDHAM, MA - 781-329-1750

ICEBRAND SEAFOODS INC. - DAVID
BENGIS - NEW YORK, NY - 212-956-2320

BBS BUSINESS SERVICES - BEVERLY
SAUNDERS - GLOUCESTER - 508-283-2367 /
FAX: 508-283-0012

D & B BAIT - JOHN CONNEELY -
GLOUCESTER, MA - 978-281-1866

INDUSTRIAL MARINE MKTG. - ROGER
SMITH - WAKEFIELD, RI - 401-782-4412

BLUE WATER ENT MARINE ENGINES -
JOSEPH GALGANA, PRES. - OCEAN BLUFF,
MA - 781-837-9826

THE DELKIN COMPANIES (BAIT) -
SCOTT NANFELT - NEW BEDFORD, MA -
508-990-0289 - SNANFELT@DELKEN.COM

IMP FISHING GEAR - JOHN REARDON -
NEW BEDFORD MA - 508-993-0010

BOB LOBSTER (FISH MKT & LOBSTER
POUND) - ROBERT HARTIGAN - PLUM
ISLAND, MA - 978-465-7100

DEXTER INDEPENDENT MARINE
SERVICES - MARINE SURVEYOR -
LADDIE DEXTER - MARSHFIELD, MA -
TEL 781-834-6426 FAX 781-837-8745

ISLAND TRAP CO - DAVID & PAM
MEDEIROS - OAK BLUFFS, MA - 508-627-5557

BRICO INC. - BRIAN FIELDING -
WAKEFIELD, RI - 401-783-6360

D&D MARINE SERVICES - MARINE
TOWING & SALVAGE - DAVE SWISS -
NEWBURYPORT, MA - 978-462-8855

JESSE'S MARINE - TED & ERIC JESSE -
PLYMOUTH, MA - 508-746-0037

BRISTOL COUNTY PRESS - GREGG
MILKA - TAUNTON, MA - 508-824-1865

DIMARE SEAFOOD CO. - RICHARD
DIMARE - REVERE, MA - 781-289-7687

JOLIN LOBSTER INC. - GEOFF SONES -
MANCHESTER, MA - 978-526-7954

BROOKLINE MACHINE COMPANY -
JOHN WHITING - BRIGHTON, MA -- 617-782-4018

THE EAST COAST MARINE DIRECTORY
- STEPHEN J. McDONOUGH - DOVER, NH -
STEPHEN@MCDONOUGH.COM - 1-800-577-9455 FAX 603-742-5168

K&A DESIGNS (THE BUBBLE) - MEL
NELSON - DANVERS, MA - (Toll Free) 888-282-2531

BY BAIT @ AOL.COM - MIKE
CANNISTRARO - 1-508-420-5556

EASTERN LOBSTER POUND - PAUL
SALKE - W. SAYVILLE, NY - 516-563-8989

K&K EQUIPMENT - CHARLES
KLECZKOWSKI - DRACUT, MA - 508-957-1110

C-TRAP - CHRIS PARKER -
MATTAPoisETT, MA - 508-758-6535

ELECTRA-DYNE - PETER MACCAFERRI -
PLYMOUTH, MA 508-747-4017

KETCHAM TRAPS - ROBERT KETCHAM -
NEW BEDFORD, MA - 508-997-4787

CAPE ANN MARINE - ANDREW
DOMINICK III - GLOUCESTER - 978-282-0806

FIRST PIONEER FARM CREDIT - ED
UNDERWOOD - MIDDLEBORO, MA - 508-946-4455

KING & SONS FISHING CO. - AL KING
(DEALER) - GLOUCESTER, - 978-281-0564 /
FAX 978-281-6936

CAPE FISHERMENS SUPPLY - ROBERT
DENN - CHATHAM, MA - 508-945-3501

FISH EXPO - PORTLAND, ME - 207-772-3005
EXT. 82

KING LOBSTERS - D.J. KING - BRANFORD,
CT - 203-488-6926

CAPE SEAFOODS (BAIT DEALER) - DAVE
ELLENTON - GLOUCESTER - 978-283-8522
dave@capeseafoods.com

FISHER AIR FASTENERS - ED & CHRIS
FISHER - PEMBROKE, MA - 781-826-2522

LAND & SEA COMMUNICATIONS - JOHN
EDNIE - HARWICHPORT, MA - 508-432-4271

CAPEWAY BEARINGS - KEN RENAUD,
PLYMOUTH, MA - 508-747-2800

FRIENDSHIP TRAP CO. - PIKE BARTLETT
- FRIENDSHIP, ME - 207-354-2545

LANDRIGAN CORPORATION - GEORGE & JOSEPH LANDRIGAN - BOSTON, MA - 617-567-2182

LEES WHARF LOBSTER - BOBBY GIFFORD - WESTPORT, MA - 508-636-6161

LITTLE BAY LOBSTER - NICK JENKINS - NEWINGTON, NH - 603-431-3170

LOBSTER TRAP CO. (DEALER) - LOGAN CLARK - BOURNE, MA - 508-759-4928

LYNCH LOBSTER CO.(DEALER) - JOHN LYNCH - BEVERLY, MA - 978-921-8088

MANCHESTER LOBSTER INC. (DEALER) TONY REZZA - MANCHESTER, MA 978-526-1338

THE MANOMET LOBSTER POUND (WHOLESALE) - DARRYL C. DURNFORD - MANOMET, MA - TEL.508-224-5600/FAX 508-224-5602

MARINE PROPELLER SERVICE - MIKE VALM - NEW BEDFORD, MA 508-979-8000

MARINE HYDRAULIC ENGINEERING - ROBERT CROWE - ROCKLAND, ME - 207-594-9525 / 1-800-747-7550

MERMAID MARINE-NORTHEAST - JAMIN JONES - GLOUCESTER, MA - 978-281-7876

MULLANEY'S FISH MARKET - CHRIS MULLANEY - SCITUATE, MA - 781-545-5000

JIM MANNING - NATIONAL MARINE FISHERIES SERVICE - WOODS HOLE, MA 02543

NAUSET RESTORATION dba Willpower - JOHN QUIGLEY - ORLEANS, MA - 508-255-7025

NEIDICH MARINE - RICHARD NEIDICH - MIDDLETON, RI - 401-846-2047

NELSON MARINE SERVICES - RONALD NELSON - SALEM, MA - 978-741-2950

NEPTUNE INC. - FRANK TORNGREN - ATTLEBORO, MA -- 508-222-8313

NEPTUNE LOBSTER & SEAFOOD'S - JOHN DAIGLE - QUINCY, MA - 617-426-0961

NEPTUNE MARINE PRODUCTS - ED WYMAN - SEATTLE, WA - 206-789-3790 - info@neptunemarineproducts.com

N.E. DETROIT DIESEL-ALLISON - DAVID KENNEDY - PORTLAND, ME - 207-797-5950 (Maine)

N.E. MARINE & INDUSTRIAL INC. - MIKE RICHARDSON (NH) 603-436-2836 - STEVE FASSNACHT (MA) 781-834-9301 - Info@newenglandmarine.com

N.E.F.D. ASSOCIATION - KEN W. COONS - CHARLESTOWN, MA - 617-443-9494 / FAX 617-443-9499

THE NET RESULT - LOUIS LARSEN - MARTHA'S VINEYARD - FAX 508-693-8139 - Mvseafod@vineyard.net

NEW ENGLAND PROPELLER - TOM PARKER - BOSTON, MA - 617-288-3132

OCEAN STATE LOBSTER - KEVIN BATES - NARRAGANSETT, RI - 401-782-3500

OCEAN WORKS - MARK AMORELLO - PEMBROKE, MA - 781-829-8880

PENDER MARINE SERVICES - PAUL PENDER - WESTWOOD, MA - 617-329-6142

PLANTE'S LOBSTER VENTS - ERIC deDOES, MGR. - SOMERVILLE, ME - 207-549-7204

PROFESSIONAL PACKAGING, INC. - CHIP ROGERS - PORTSMOUTH, NH - TEL (306) 433-3163 / FAX (603) 433-3139 - www.professionalpackaging.com

JIM REARDON - BUS - 617-269-9825 CELL 508-889-7484 - EMAIL: jimreardon@earthlink.net

RIVERDALE MILLS - ANDREW KNOTT - CRAIG PENNYPACKER - NORTHBRIDGE, MA - 508-234-8715

R N R MARINE SUPPLY
781-585-1910

ROSE'S MARINE OIL - KEN JENKINS - GLOUCESTER, MA - (978)-281-7428

ROWAND FISHERIES INC. - ELLIOTT ROWAND - BEVERLY, MA - 978-927-1871

SANDWICH SHIP SUPPLY - DON SPRING SANDWICH, MA - (508)-888-0200

SEAFOOD PROCUREMENT & MKTG - SPIROS TOURKAKIS - LYNN, MA - TEL 617-593-1737 FAX 617-598-2492

SEAFOOD USA - DAVID REALE - HUMAROCK, MA - (781) 837-7666

SEALAND POWER / MARINE ENGINE CENTER - LINDEN, NJ - ALAN WACHSTEIN 1-800-225-0004

SEALURE LOBSTER BAIT - MONUMENT BEACH, MA - (Toll Free) 800-756-7848

SEA PRODUCTS CO. - HENRY J. FERRI - NO. FALMOUTH, MA - 508-563-6217

SEAWAY MARINE - LARRY BONIER - MIDDLETON, RI - 401-847-7775

SINKO USA - BILL BROWN - NORTHPORT, NY - 516-368-9168

SOUTHWORTH-MILTON POWER - DONALD MACPHEE - MILFORD, MA - 508-634-3400

SOUZA'S SEAFOOD - MANUEL SOUZA III - NANTUCKET, MA - 508-228-9140

SPURS MARINE MANUFACTURERS - DON GOVAN - PATRICK JANDEBEUR - FT. LAUDERDALE, FLA - 1-800-824-5372

TBS ADJUSTING, INC. - STEPHEN HOLZENTHAL - NEW ORLEANS, LA - 504-524-2301

T&S LOBSTER - TERRY MCDUGAL - WATERFORD, CT 860-447-3635

THISTLE MARINE LLC - RICHARD ARNOLD - LAMOINE, ME 207-667-8200 - Richarda@thistlemarine.com

TAPPER'S COVE SEAFOOD - FRANK TAPPER - FAIRHAVEN, MA - 508-984-3634

TOP-ME PRODUCTS - DONALD ERLANDSON - TOPSHAM, ME - 207-729-6676

TICHON SEAFOOD CORP. - PAUL SAUNDERS - NEW BEDOFRD, MA - 508-999-5607

TYCOM US INC. - TOM SHINSKEY - MORRISTOWN, NJ 973-656-8753 - www.tycomltd.com

TWO COUSINS FISH MARKET - BRIAN O'DONOHUE - FREEPORT, NY - 516-379-5065

VICTORY .FISHERIES - ALEX BROWN - PROVINCETOWN, MA - 508-487-0471

VIOLET FISH & TRAP CO. - JAMES VIOLET - MIDDLETOWN, RI - 401-847-8731

W.B. VAN DUZER CO. - WILLIAN VAN DUZER - DUXBURY, MA - 781-585-7664

WESTERBEKE FISHING GEAR - CHRIS HALLIGAN - BOSTON, MA - 617-561-9967

WINCHESTER FISHING - DICK WINCHESTER - GLOUCESTER, MA - 978-281-1619

YANKEE FISHERMEN'S CO-OP. - SEABROOK, NH - 603-474-9850

YANKEE LOBSTER CO., INC. - JOSEPH FARO - BOSTON, MA - 617-542-1922

YOUNG BROTHERS & COMPANY - ARVIN YOUNG - COREA, ME - 207-963-7467

BUY - SELL - SWAP (DEC2002)

PLEASE NOTE: ALL ADS WILL RUN FOR 4 MONTHS ONLY AND THEN WILL BE REMOVED. ALL F/N ADS WILL RUN FOR 6 MONTHS. IF YOU WANT YOUR AD TO RUN LONGER YOU MUST CALL BEFORE THE DEADLINE TO RENEW IT.

#1750 (F/N)
LOBSTER TRAPS - 4 FT. FISHED 6 MONTHS ON MUD BOTTOM. \$40.00 - CALL 508-822-0830

#1795 (F/N)
WALTERS KEEL COOLERS FROM H&H. 8 TUBES (+4 EXTRA'S) 5-FT LONG. SINGLE INLET / 2" PIPE IN + OUT. USED ON 300+ HP CAT ENGINE. CALL CHUCK 781-335-5356 ASKING \$1,200 OR BEST OFFER.

#1887 (9/02)
22 FT BOSTON WHALER, 175 JOHNSON, CUSTOM PHONE BOOTH STEERING STATION, SWIVEL ROD HOLDERS, LORAN, RADIO. \$9,500. WORTH MUCH MORE 781-837-5424

#1888 (9/02)
LOOKING FOR USED TRAPS
3-4 FOOT \$20. 978-281-1744

#1889 (9/02)
1980 34' LOBSTER BOAT, 3208 CAT, WOODEN AND SOLID, FIBERGLASS TOPSIDES, BATTEN SEAM CONSTRUCTED, STAINLESS STEEL FASTENED. \$25,000 781-821-2043

#1890 (9/02)
SELF-CONTAINED LOBSTER TANK, CHILLER LOCATED UNDER TANK, HOLDS APPROX 200 LBS. \$1,200 781-821-2043

#1892 (9/02)
44' STANLEY LOBSTER BOAT, 1978, V8 - 71 GM RECENTLY REBUILT. TD MG-509 WITH TROLLING VALVE. BELOW-DECK TANKS. SPLIT PILOT HOUSE, NEW EPIRB, 6-MAN SWITLIK LIFE RAFT. DIESEL-FIRED TRAP COOKER. LIMITED ACCESS LOBSTER, SCUP AND BLACK SEA BASS PERMITS. \$130,000 WITH PERMITS. WILL SEPARATE. ALSO 48x24x15 FRIENDSHIP TRAPS AVAILABLE. CALL DICK ALLEN AT 401-789-1463

#1893 (9/02)
21' PRIVATEER W/175 EVINRUDE AND A DUAL AXLE ROLL ON TRAILER. RIGGED FOR TUNA FISHING. 9 SWIVEL ROD HOLDERS, 40 GAL. LIVEWELL, LORAN, GPS, VHF, FURUNO FCV-667 COLOR SOUNDER, REMOTE SPOTLIGHT, WASHDOWN HOSE, CAT.II EPIRB, REVERE IBA RAFT, FLARE KIT AND LIFE RING. ASKING \$16,900 OR BEST OFFER. 978-282-4663

#1894 (9/02)
WANTED
MASS COASTAL LOBSTER LICENSE
978-281-1816

#1895 (9/02)
31' 1992 BHM, CUMMINGS 210 DIESEL, 12" STAINLESS STEEL HAULER, DIRECT DRIVE, LARGE PUMP & TANK, FULL ELECTRONICS, RADAR, WASHDOWN PUMP, BUILT IN HEAD. \$55,000 **COASTAL MA LOBSTER LICENSE** \$5,000 WITH BOAT, \$8,000 ALONE. **USED TRAPS** \$20 EA. WITH ROPES.

1992 FORD F150 XLT TRUCK, 302 ENGINE, AUTOMATIC, NEW ENGINE & TRANS. 100 MILES ON NEW ENGINE. \$1,995
CALL 781-383-1160

#1896 (9/02)
BAIT
COWHIDE 5-GAL PAILS. \$65. EACH
CALL TIM AT 781-834-6733

#1897 (9/02)
INSHORE OLD LOBSTER PERMITS. NOTE: PERSON WHO BUYS PERMIT MUST BE ON THE CURRENT LIST WAITING TO PURCHASE. - **FEDERAL LOBSTER PERMIT** ALSO FOR AREA'S 1,2,3. AMERICAN LOBSTER, COMMERCIAL CRAB, BLUE FISH PERMITS. **26 FT GLASS AND MAHOGANY MANINO BOAT**, NEW REBUILT VOLVO 200 HP DIESEL. TAMD 41A. OVER \$8,000 WORTH OF VOLVO PARTS. NEW SS SHAFT 1 1/4", NEW 73 SERIES GEAR 2:1 RATIO. ALSO, **250 32" WOODEN TRAPS**, NOW FISHING. ASKING \$40,000 FOR BUSINESS. CALL BOB AT 508-746-6972

#1898 (9/02)
35' LOBSTER BOAT
\$8,500

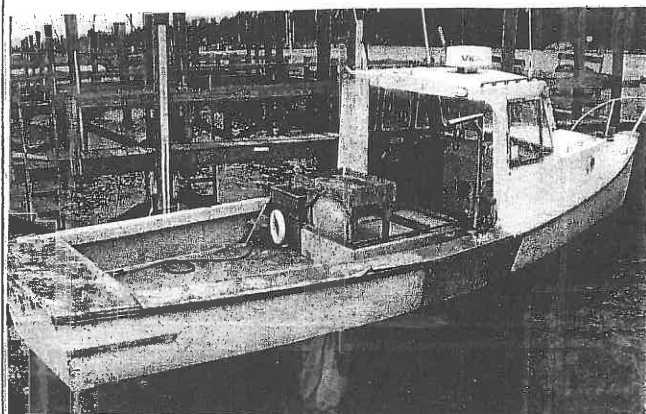

135 HP FORD NORTHEAST DIESEL, GLASS OVER WOOD, 10' BEAM, 12" HYDRAULIC HAULER, VHF, NORTHSTAR LORAN, WASHDOWN, 300# HOLDING TANK. GOOD CONDITION. CALL (631) 269-4607 OR EMAIL EAG153@HOTMAIL.COM

#1900 (9/02)

41 FT MORGAN 1990 LOBSTER BOAT

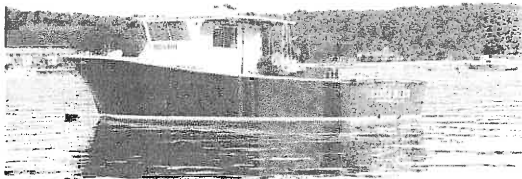

8V71 GM REBUILT COMPLETELY WITH NEW 2:1 GEAR, ONLY 200 HRS. FULL ELECTRONICS (COLOR SOUNDER, 2 GPS, LORAN, RADAR, 2 VHF RADIOS) EXCELLENT BOAT FOR INSHORE OFFSHORE FISHING. **HIGH BOW** CURRENTLY FISHING. WOULD BE GREAT CANYON SPORT BOAT. ONLY \$80,000. **ALSO, 500 48x24x13.5 HEAVY DUTY BUILT LOBSTER TRAPS WITH SINKO RUNNERS. FISHED ONLY 6 MOS @ \$50. EACH. TEL: 631-754-1067 CELL: 631-680-5937**

#1901 (10/02)

18' TRI WERX WOODEN SKIFF WITH C/C 40 HP MARINER ELEC. START LONGSHAFT POWER TRIM TILT, VENTURE TRAILER, ALL NEW DEC 1999. LESS THEN 20 HRS. WILL SEPARATE. \$4,200 OR BEST OFFER OR TRADES. 978-283-2517

#1902 (10/02)

CRYSLER MARINE SLANT 6. COMPLETE, RUNS, HAS BAD VALVE, WITH SPARE PARTS. \$500 OR B/O 978-283-2517

#1903 (10/02)

FEDERAL LOBSTER PERMIT - AREA 2 - GOOD HISTORY - 400 TRAPS / YOU PICK FROM 800. 20K 401-635-4615

#1904 (10/02)

46' JARVIS NEWMAN, LIKE BRAND NEW, WITH OR WITHOUT PERMITS, TOO MUCH TO LIST. TAKING BEST OFFER 631-757-8264 (NY)

#1905 (10/02)

1998 600HP E7 MACK, 1,350 HOURS. LIKE NEW. ASKING \$19,000. 631-375-4947 (NY)

#1906 (10/02)

TRAC RAC SYSTEM FOR 8' PICK-UP BED. WILL FIT FORD, CHEVY AND DODGE FROM 1972-1993 \$450. 781-254-9153

#1907 (10/02)

1989 PROVINCIAL CONSTRUCTION 42' ALL GLASS, HEAD, TABLE, 2 BUNKS, STAINLESS DAVIT, TINTED GLASS, WELL MAINTAINED, RADAR, GPS, 14" HAULER, GEN PUMP, PITTS CLUTCH, OPEN STERN, NEEDS RE-POWER. BEST REASONABLE OFFER. 781-871-6027

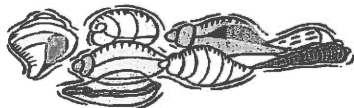

#1908 (10/02)

LOOKING FOR AN INSHORE LOBSTER LICENSE WITH GOOD SOLID HISTORY 978-985-9549

#1909 (10/02)

37' FROST BUILT LOBSTER BOAT. ALL WOOD, NICE LINES TO THIS BOAT. NO ENGINE. BOAT IS DOCUMENTED. NEEDS A LITTLE TLC. \$4,000 OR BO 508-432-7930

#1910 (10/02)

21' PRIVATEER - CENTER CONSOLE W/T-TOP, 175 HP EVINRUDE, DUAL AXLE TRAILER, FURUNO GPS AND COLOR SOUNDER, LORAN-C, VHF, DUAL BATTERIES, REMOTE SPOTLIGHT, WASHDOWN HOSE, 9 SWIVEL ROD HOLDERS, 40 GAL. LIVEWELL, LIFE RAFT, CAT. II EPIRB, LIFE RING AND FLARE KIT. GREAT TUNA BOAT! ASKING \$16,900 OR BO CALL BG BROWN @ 978-282-4663

#1911 (10/02)

44' STANLEY / F/V SEAWIFE - CAT 3406-B - 8-KW NORTHERN LIGHTS GEN, FEDERAL PERMITS / COASTAL ACCESS PERMIT, MULTI-SPECIES D.A.S., OFFSHORE LOBSTER, MUCH MORE - BUILT TO LAST 508-888-4216 PLEASE CALL BEFORE 8:00 PM.

#1912 (10/02)

COMPELTE LOBSTER BUSINESS 1998 30' GLASS H&H MARINE, 260 CUMMINS WITH 750 HRS. 2 RADIOS, RADAR, COLOR DEPTHFINDER AND GPS PLOTTER. STATE LOBSTER & GILLNET PERMIT, FEDERAL LOBSTER PERMIT AND OTHER MISC PERMITS. 600 36" WIRE TRAPS, 12' CAROLINA SKIFF W/15 HP MERCURY. MOORING AVAILABLE. WILL SELL BOAT SEPARATELY, WOULD MAKE EXCELLENT TUNA OR CHARTER BOAT. CRUISES AT 15 KNOTS TOPS AT 20 KNOTS. \$120,000. 781-837-4868 ASK FOR TERRY.

#1913 (10/02)

36' BOB RICH BUILT LOBSTER BOAT 1971 - 471 MARINE DIESEL ENGINE. MA COASTAL LOBSTER LICENSE INCL. \$30,000 ASK FOR DON 978-281-1886

#1914 (10/02)

45' LOBTER BOAT, SPLIT WHEELHOUSE, 871, FULL ELECTRONICS & SAFETY GEAR. 3 BELOW DECK LOBSTER TANKS, 800 TRPS, FEDERAL LOBSTER LICENSE AREA 2&3, MA STATE LOBSTER LICENSE, SCUP, SEA BASS, SURF CLAM, OCEAN QUAHOG. \$120,000 508-636-5037

#1915 (10/02)

24' NAUSET FIBERGLASS POT BOAT FULL WINDER BACK, SS. HAULER & DAVIT, COLOR SOUNDER, AUTOPILOT, RADAR, PLOTTER, HAS A NEW WORK DECK, SHAFT, PITTS CLUTCH, FUEL TANKS. BOAT HAS BEEN WELL TAKEN CARE OF. 453 DETROIT DIESEL WITH 502 TWIN DISC GEAR. JUST SANDBLASTED AND REBUILT. \$25,000. 508-758-3863

#1916 (10/02)

35' ATKINSON 1989 LOBSTER BOAT – NEW DECKS, TANKS, SHAFTS, PROP. 71B VOLVO 380 HP. CRUISES AT 14 KTS. 2 LORANS, NEW RADAR, VHF, DIRECT DRIVE W/CLUTCH. 1 ½" WASHDOWN W/CLUTCH. SPLIT WHEELHOUSE, FAST & CLEAN. \$50,000 CALL BILL AT 781-639-8301

#1917 (10/02)

**FIBERGLASS NOVI LOBSTER BOAT - \$68,000
41"4" X 14'8"**

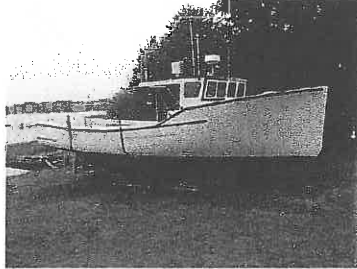

BRUCE ATKINSON HULL, OPEN STERN, 6-71 DETROIT DIESEL 509 TWIN DISC TRANSMISSION, 14" POT HAULER, **FEDERAL LOBSTER PERMIT**, FURUNO RADAR, NORTHSTAR GPS & NORTHSTAR LORAN. WELL KEPT. \$68,000
CALL 781-337-7597

#1919 (10/02)

LOBSTER BOAT WANTED

MUST BE: REASONABLY PRICED, 30-40 FT SOLID FIBERGLASS HULL AND MUST BE U.S. BUILT. WILL CONSIDER BOATS NEEDING MECHANICAL AND OR OTHER WORK. BHM, WEBBERS COVE, JC, ETC. 781-799-9849

#1920 (10/02)

30 FOOT YOUNG BROTHERS LOBSTER GILLNETTER, 210 CUMMINS, TWIN DISC, 1300 HOURS, TOP 21 KTS, CRUISE 17 KTS. NEW ELECTRONICS, WASHDOWN AND HYDRAULICS, WITH GILLNET REEL AND PERMITS. GOING BIGGER. \$52,000. WILL SEPARATE GILLNET REEL AND PERMITS. CALL 516-541-6596

#1921 (11/02)

28x28 **RECONDITIONED PROP 2" BORE \$500 OR BEST OFFER – 20' CUSTOM BUILT DUAL AXLE TRAILER**, WILL HAUL 120 LOBSTER POTS. \$975 OR BEST OFFER. CALL RON AT 508-997-9860 OR CELL 508-509-1243

#1922 (11/02)

45' YOUNG BROS, 1982, 8V92 DETROIT, TWIN DISC 2.5:1 REBUILT 1996, SPLIT WHEELHOUSE, OPEN STERN. 6 BELOW DECK LOBSTER TANKS WITH 3,000 LB. CAPACITY 500 GAL FUEL, 4 V-BERTHS, BUS HEATER, JRC RADAR, NORTHSTAR 951X GPS, NORTHSTAR 800 LORAN, ROBERTSON AUTOPILOT, FURUNO COLOR SOUNDER, 2 VHF'S, CB, NEW PROP 2000, HULL AWLGRIPED IN 2000, TRAP FENCE, THIS BOAT IS IN EXCELLENT SHAPE AND READY TO GO. \$130,000 PERMIT ALSO AVAILABLE. CALL 401-789-0332 LEAVE MESSAGE.

#1923 (12/02)

**1 ½" STAINLESS PROPELLER SHAFT
9' -10" LONG - \$125. CALL 401-635-4392**

#1924 (11/02)

NETS / TRAPS FOR SALE

\$50. - 280 – 48 x 24 x 13 ½ - FISHED 1 SUMMER
\$35. - 240 – 48 x 24 x 13 ½ - FISHED 5 SUMMERS
\$30. - 30 – 12 x 12 x 18 GAUGE MONK NETS
\$25. - 50 – 12 x 12 x 18 GAUGE / 150 FATHOM MONK NETS
CALL 401-842-8165

#1925 (11/02)

40' FIBERGLASS GILLNETTER – 6V92 DIESEL, 24" GILLNET LIFTER, FULL ELECTRONICS & SAFETY GEAR. \$25,000 CALL 978-281-2411

#1926 (11/02)

7 8V BATTERIES - \$50.
1 32V LEECE-NEVILLE ALT. (115 AMP) - \$350.
1 32V DELCO STARTER (12 TEETH) - \$150.
1 32V WOOD FREEMAN 500B JOG LEVER - \$200.
1 24V SEA LEVEL BUS HEATER - \$50
1 32V ALARM BELL – FREE
1 32V JABSCO 2" PUMP W/ELECTRIC CLUTCH - \$100.
CALL 401-842-8165

#1927 (11/02)

**WANTED – WANTED – WANTED
MASS. COASTAL LOBSTER LICENSE
CALL 508-636-2144**

#1928 (11/02)

**50 FRIENDSHIP WIRE TRAP KITS – 36 X 22 ½ X 15 – SHRIMP MESH HEADS, NO BRICKS, NO RUNNERS - \$20 EACH.
50 MISC TRAPS - \$10 EACH. CALL DON 781-834-7079**

#1929 (11/02)

**34 X 13 FOOT FIBERGLASS LOBSTER BOAT
CAT 3116 300 HP
THIS BOAT WAS REBUILT IN 1998
EVERYTHING NEW
SPLIT WHEELHOUSE, ALL FURUNO
ELECTRONICS, PLOTTER, RADAR, SOUNDER
3 RAYTHEON LORANS
STAINLESS HAULER, DAVIT
ELECTRIC CLUTCH ON 2 WASHDOWN
MUST SEE
\$65,000 OR BEST OFFER.
CALL JUSTIN AT 781-477-2977 OR 781-789-8301**

#1930 (12/02)

COMPLETE BUSINESS FOR SALE

25 FT, 10 FT BEAM, FIBERGLASS BOAT BUILT IN NOVI IN 1969; 1998 135 HP MARINER OPTIMAX, LOW HOURS; 10" ELECTRO-DYNE HAULER, ELECTRONICS, RUNS 6-POT TRAWLS; 225 TRAPS, ROPES, AND BUOYS. **FEDERAL LOBSTER OFFSHORE AND MASS. COASTAL LOBSTER PERMITS. SOLD AS PACKAGE ONLY BUT WILL CONSIDER SELLING FEDERAL LOBSTER PERMIT SEPARATELY. MAKE OFFER CALL BOB AT 781-767-2310 OR ARTHUR AT 508-888-2394**

#1931 (11/02)

**RUNNING TAKE OUT - 1996 VOLVO 72A
430 HP WITH APPROX. 7,000 HRS ENGINE COMPLETE.
WITHOUT GEAR. \$4,000 OR BEST OFFER.
CALL PETE AT 508-830-9779**

#1932 (11/02)

REBUILT CATERPILLARS

3208TA'S, 3116'S, 3126'S, CUMMINS 6B, 6C, TWIN DISC GEARS, PROPS, SHAFTS, U.S. PUMPED AND REFINED OIL, (NONE OF THE PROCEEDS GOES TO THE MIDDLE EAST)
CALL 781-837-5424 – WILL DELIVER



#1933 (11/02)

**TURN-KEY OPERATION
\$95,000**

41.5' 1985 BRUCE ATKINS FIBERGLASS AIREX CORE HULL

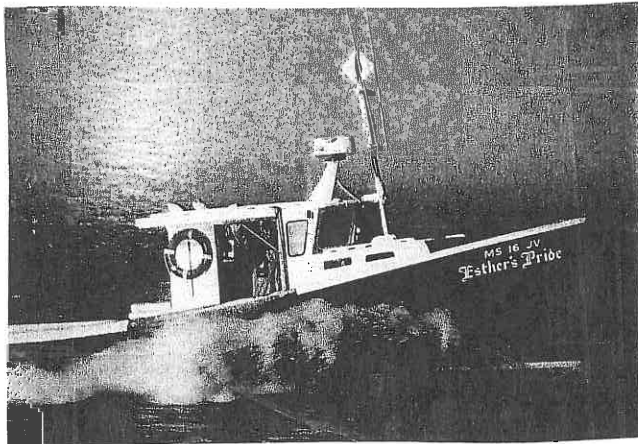

**1998 CUMMINS 400 HP ENGINE,
507 TWIN DISC GEAR (4,000 HR). IN 2002 NEW DECK,
2 FIBERGLASS FUEL TANKS, 380 GAL AND SS. EXHAUST,
SPLIT WHEELHOUSE, 14" HAULER,
2 ROLLS ROYCE BATTERIES
SITEX DEPTH SOUNDER, RADAR AND LORAN
SINK AND STOVE
800 TRAPS WITH ROPE AND BUOYS
MASS & FEDERAL LOBSTER LICENSES AND TUNA PERMIT
LOTS OF EXTRAS
\$95,000.
CALL JOHN AT 978-646-8801**

#1934 (12/02)

**WANTED ~ WANTED ~ WANTED
16' FIBERGLASS WORK SKIFF
(JUST A SKIFF, NO OUTBOARD OR TRAILER)
NEW BEDFORD AREA - CALL 508-748-1891**

#1935 (12/02)

**FEDERAL LOBSTER PERMIT
AREA 1 - GOOD HISTORY
\$8,000
CALL 781-447-0750**

#1936 (12/02)

**6-PERSON LIFERAFT - SWITLIK - LAST INSPECTED 1996,
NEVER DEPLOYED IN OCEAN. \$300. CALL JACK AT 508-
945-3679**

#1937 (12/02)

**FISH BOX - INSULATED, F/G 4x3x5 WITH COVERS. \$250
CALL JACK AT 508-945-3679**

#1938 (12/02)

**BED LINERS FOR PICK-UP TRUCKS - 2 FORD OR DODGE
\$30 EACH. CALL JACK AT 508-945-3679**

#1939 (12/02)

**TAILGATE - FORD PICK-UP TRUCK TAILGATE - GOOD &
FUNCTIONS. \$50. CALL JACK AT 508-945-3679**

#1940 (12/02)

**TWO (2) 28x26x2 4-BLADE LEFT-HAND
BOTH RECONDITIONED - \$500 EACH 781-447-0750**

#1942 (12/02)

**5 FT WIRE STRAIGHTENER
LIKE NEW - \$400 OR B.O.
978-546-9493**

#1943 (12/02)

**1985 35' BRUNO LOBSTER BOAT
\$49,900**

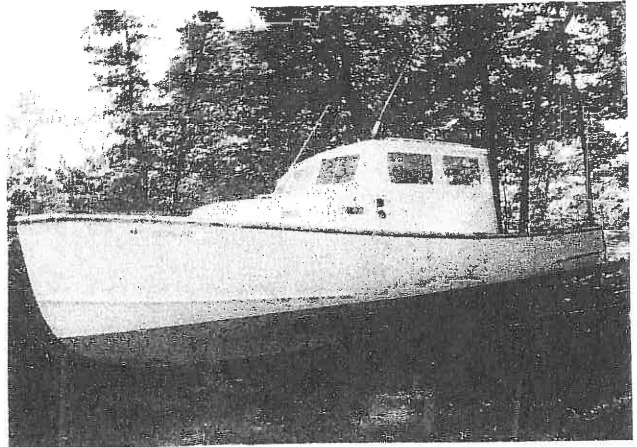

**BUILT BY NAUSET, BOAT HAS A 230 MERC CRUISER
MOTOR WITH A 100-GAL GAS TANK, 12" HAULER, NEW
MOTOR IN 1995 WITH ABOUT 300 HRS ON IT. BOAT IS ALL
FIBERGLASS. DOES 23 KTS, HAS WASH DOWN PUMP, OPEN
STERN, ETC. CALL FOR DETAILS \$49,900.
THIS IS A STEAL AT THIS PRICE.
CALL TONY AT 978-670-2463 OR 978-670-1845**

#1944 (12/02)

**22x22 RH MICHIGAN DYNAQUAD - USED 3 MONTHS - MINT
CONDITION \$600 CALL 508-224-3418**

#1945 (12/02)

**FEDERAL LOBSTER LICENSE
FOR DETAILS CALL 508-487-9258 OR 508-487-0420**

#1946 (12/02)

**USED FISH TOTES
\$4.00 EACH FIRM (100 AVAILABLE)
CALL 978-777-8591**

#1947 (12/02)

**38' X 16 ATKINSON GLASS OVER WOOD
DOUBLE RIBBED, 12" HYDROSLAVE HAULER, GPS, VHF,
454 GAS ENGINE, REBUILT TRANSMISSION, GOOD SEA
BOAT WITH FEDERAL LOBSTER PERMIT & 200 WIRE TRAPS.
\$20,000 CALL 781-596-0518 AFTER 5 PM.**

#1948 (12/02)

**LOBSTER BUSINESS FOR SALE
28' NOVI GLASS OVER WOOD LOBSTER BOAT
292 CHEV GAS ENGINE. BOAT CURRENTLY OVERHAULED,
WIRING, HYDRAULICS, 24 GAL. GRESSEN PUMP, DIRECT
DRIVE WITH ELECTRIC CLUTCH, HEAT EXCHANGER,
BELOW DECK FIBERGLASS FUEL TANK, READY TO FISH
WITH INSHORE LICENSE & 200 WIRE TRAPS
\$20,000 781-596-0518 AFTER 5 PM**

#1949 (12/02)

**WANTED ~ WANTED ~ WANTED
YOUR WOOD TRAPS - ANY SIZE - CASH WAITING
CALL BILL FOR MORE INFO AT 413-237-0063**

#1950 (12/02)

~ WANTED ~
MASS. COASTAL LOBSTER PERMIT
CALL 781-925-3424

#1951 (12/02)

30' YOUNG BROTHERS
210 ISUZU, FURUNO SOUNDER, LORAN & RADAR
RAYMARINE AUTOPILOT
200 POTS & FEDERAL LOBSTER PERMIT
\$45,000 CALL BOB @ 508-759-8929

#1952 (12/02)

WIRE TRAPS FOR SALE - 48x28x18 \$10 EACH.
ALSO, WOOD TRAPS, THE BEAR TRAPS ONCE MADE BY
ANDERSON 48x32x18 ALL READY TO FISH. GROUND LINE
INCLUDED \$10 EACH. FOR INFO CALL BILL AT 413-237-0063

#1953 (12/02)

F/V GLUTTON
28' 1984 CAPE DORY TRAWLERS LOBSTER/TUNA
18 CRUISE 21 TOP
CUMMINS 68T 210 HP 1800 HRS
NEW DIGITAL TAC (SEPT 2002)
NEW 690A ZF TRANSMISSION 20 HRS (SEPT 2002)
NEW 12" HYDROSLAVE HAULER WITH SPARE PUMP
JABSCO / RULE WASHDOWN
2 BILGE PUMPS - ICOM RADIO - NORTHSTAR 800
RURUNO RADAR - BOMAR HATCHES
\$45,000.
CALL 508-487-2625

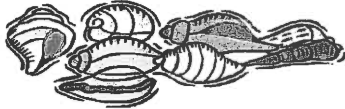

THE MLA NEWSLETTER IS
THE PLACE TO FIND ALL THE
BEST DEALS. GOT SOMETHING
TO SELL? THIS IS THE PLACE
BUT BE SURE YOU SEND
IT IN BEFORE THE DEADLINE.

ALL ADS ARE ALSO PUT ON THE
MLA'S WEBSITE FREE OF CHARGE
(For our members only, of course).



NOTE: THE NEXT ISSUE (JANUARY'S NEWSLETTER) WILL BE AVAILABLE AT THE ANNUAL WEEKEND WHERE NON-MEMBERS WILL ALSO BE ABLE TO PICK UP A COPY. IF YOU PLAN TO PUT AN AD IN THE JANUARY NEWSLETTER, PLEASE MAKE SURE WE HAVE YOUR AD BEFORE THE DEADLINE.



BAIT
BARRELS, TOTES & FROZEN

Sea Herring
Pogies
Mackerel
Flats
Redfish

508-888-0096

THE BAIT LADY

Sandwich MA Division

20 Freezer Road

Sandwich, MA 02563



MASSACHUSETTS LOBSTERMEN'S ASSOCIATION, INC.

DECEMBER 2002 NEWSLETTER

DELEGATES PLEASE NOTE: The next Delegates meeting will be held on **Wednesday, December 18, 2002** at the Son's of Italy Hall, Quincy, MA at 7:30 PM.

ASMFC LOBSTER BOARD DISCUSSES V-NOTCH EVALUATION METHODS AND AREA 2 LOBSTER CRISIS

There were no compliance votes taken by the ASMFC's Lobster Board against any state including Massachusetts during the November 20th meeting of the Board. During the plan review teams report, however, there was a lengthy discussion on the issue that most states had not implemented the regulations set forth for Areas outside their jurisdictions. This involved, for example, that Massachusetts and other states as well, had not put into their regulations the rules for Areas 4, 5, 6 and had only set up regs for, in Massachusetts' case, Areas 1, 2, 3 and the Outer Cape. It was noted that the states had until June 2003 to take care of this.

There also was a lengthy discussion on the most restrictive rule requirement. The basic plan, Amendment 3, implemented in 1997 states that in dealing with fishermen who may designate more than one Area on their permit, the most restrictive rule applies to that fishermen no matter where he fishes. This was always accepted for most provisions. As an example, if one designates Area 1 and Area 2 or the Outer Cape, that fisherman would be bound by the higher minimum size (Area 2 and O.C. rule) and he would also be bound by the 5" maximum size and the v-notching program (Area 1 rules). He would be bound by those rules no matter where he fishes. While this has been understood, it was noted that this was not intended to be the case if one area had a flat trap limit (800) as some areas have, and another area had an historical participation transferable trap program. In this case the idea had always been that if one qualifies to fish in the historical participation area that the fishermen would be bound to fish the qualifying number in that area or the 800 in the area with the flat trap limit. As an example here, if one qualifies for 200 traps in Area 3 but also fishes in Area 1, he could fish 200 in Area 3 and 600 in Area 1 or all 800 in Area 1 and none in Area 3. Under the current wording, he would be bound to the most restrictive rule, which would mean he could only fish 200 traps total anywhere. The Board will be considering how to fix this wording.

The Technical Committee indicated that they are prepared to use a model that will determine the rate of v-notching being done in Area 1. The Board voted to have the Technical Committee provide the first read-out, based solely on the fall trawl survey, when the Board meets again in February. The Board also indicated that other methods of evaluating the performance of the v-notch program besides this one computer model would also be acceptable. It was noted that it would be unacceptable to the Massachusetts lobster industry to base any decision on whether the program is working on one set of surveys done in early fall of 2002. The reasons noted here was that (1) the program only started in July 2002, (2) the fishermen must first catch an egger in order to v-notch it, (3) the biggest portion of v-notching by the fishermen is occurring between September and November so the survey wouldn't show the extent of notching being done yet, (4) the biologists need to use data from trap sampling and not just a trawl survey in order to get enough information to get an acceptable amount of samples to plug into any computer model. The issue here revolves around the Massachusetts provision in the Addendum III that states that if the "observed" rate of v-notches is not at 50% by the end of 2002, the Commonwealth may take further steps to ensure that the Area 1 plan meets its goal. Director Diodati indicated that he wants this report by February to use as a starting point and not necessarily as a determining factor as to whether to take any further action. The Technical Committee Chair, DMF's Bob Glenn, was asked whether the Technical Committee believes these plans will meet the goals and it was indicated that the Technical Committee does not think the Area plans will do the job needed because while they potentially raise egg production, they don't lower the removal rate (?!?!)

DMF Director Diodati also submitted a letter to the Board updating them on what Massachusetts is doing to meet its obligations under Addendum III. (See Notice Section for copy of the letter). The letter included a copy of the *Commercial Fisheries News* article on his Trap Cap Plan (Nov.2002 edition).

There was also a lengthy review of the lobster stock crisis in the Southern Inshore Stock Area (Areas 2 and 6). The focus here was primarily on Area 2. The Technical Committee indicated that stock declines and severe landing declines are cause for alarm. It was noted that factors other than fishing may be a large part of the problem. Shell disease, high water temperature and other environmental or natural factors may well be the culprits in the area but something still needs to be done to keep the fishery from a complete collapse in that area. The Board decided to form a sub-committee of Board members from Area 2 (MA, RI, CT) as quickly as possible to determine objectives for the Area 2 LCMTs in order for them to address these problems. This will mean that the Area 2 LCMTs will be called into session to work on some actions the ASMFC could take. There was no discussion on the "tabled" Addendum IV proposal for an historical participation transferable trap reduction program for Area 2.

The Board did decide to hold a working group of Board members early in 2003 to continue their discussions on the transferable trap concept. Among other agenda items, the Law Enforcement Committee stuck to its recommendation that recreational traps should all be tagged. This was in response to Massachusetts request to allow an alternate method of marking recreational buoys instead of having to issue, somehow, trap tags for every recreational lobster fisherman. The Board took no action on the issue. The Board turned down a request by Massachusetts to allow a second lobster biologist from the Commonwealth to sit as a member of the Lobster Technical Committee. Currently each state and NMFS has one lobster biologist on the Committee and each state has one vote. DMF's Bob Glenn is the Massachusetts member and is now the Chair of that Committee.

THE MLA 2003 ANNUAL WEEKEND IS COMING

Make sure you mark your calendar now and clear your schedule for January 23rd thru January 26th (Thursday – Sunday) so you won't miss the MLA 2003 edition of its Annual Weekend and Lobster Trade Show event at the Sea Crest Oceanfront Resort and Conference Center in No. Falmouth, MA. We will be celebrating 40 years as an Association. This is still the least expensive way to have a little vacation and a lot of fun. Let's face it, you've worked hard and you need a break.

Although you should have already received your reservation packet in the mail, we've included some of the basic parts in this newsletter just so you can't use the "lost form" excuse.

This years fun time will include the seminars, prizes, more prizes, casino night, bingo, Nancy and Gayle's craft class, the trade show with, this year, 6 Canadian boat builders present along with trap, engine, fishing supplies and other great dealers. We will have all of this plus the *infamous* hospitality suite, the good food and of course the assorted cast of characters, including yourself that makes this event one you shouldn't miss.

Although all the details and times of the seminars are still being finalized, here are some of the topics. Friday afternoon, as well as Saturday, will be needed to fit them all in.

- **Dr. Bob Stenech** and possibly **Susan Waddy** will be returning this year by popular demand to discuss aspects in lobster research. The Lobster Institute will be sponsoring this part of the program.
- There will be a seminar on the **MWRA Outfall Pipe Monitoring** with Battelle Lab & MWRA Representatives along with the Center for Coastal Studies personnel who are conducting independent monitoring of the affects of the outfall pipe on Cape Cod Bay and Massachusetts Bay.

- A Lobster Technical Seminar on stock assessment and egg production for all lobster Areas. This will include Lobster Technical Committee biologists and chaired by DMF's Bob Glenn.
- A round table discussion on what research and statistical studies fishermen feel need to be done that are not currently being done. This seminar will be conducted by Lobster Institute's Director Dr. Bob Bayer and Gulf of Maine Lobster Foundation representatives Patrice Farrey and Pat White. These two industry sponsored entities are capable of getting needed projects funded and operational.
- Lobster Bait – A discussion of the herring bait industry with Dave Ellington from Cape Seafoods in Gloucester plus a herring boat Captain.
- An E-Molt project update on water temperature and salinity with Jim Manning, MLA's Dave Casoni and Gulf of Maine Foundation Director Patrice Farrey.
- The Tax Seminar on how to *legally* keep more of what you earn.

It will also be important that you bring your current MLA membership card with you whether you come for the whole weekend or just for the day. (Remember, the current card is laminated and is a very light gray – *it may look white to some*).

There will be a \$5.00 entrance fee to the event for the day except for MLA members (and their wives or girlfriends) who get in for free – bring your card – There's also the MLA members raffle available only to MLA members and the ticket is free – bring your card!

Make your reservations as soon as you can because when the rooms are gone – they're gone. We have already received more reservations than this time last year and it is still only November. Remember, we accept MasterCard and Visa. You can also register online at www.lobstermen.com.

DOGFISH PLAN APPROVED BY THE ASMFC

The Atlantic States Marine Fisheries Commission approved the interstate Fisheries Management Plan (FMP) for Spiny Dogfish during its meeting week held in Virginia from November 17 – 21. The FMP compliments the existing federal regulations for dogfish, which employs a constant fishing mortality strategy.

The Plan also directs the Management Board to establish an annual commercial quota based on the status of the stock and is allocated between the same two periods in the federal fishery (May 1 – Oct 31 and November 1 – April 30). Currently the coast wide quota is 4 million pounds. To control the rate of harvest, state trip limits are also to be set annually by the Management Board.

Massachusetts voted against the Plan both at the Management Board level and again during the final vote taken by the full Commission. During the full Commission vote, the Commonwealth was the only state to oppose the passage of the Plan. Massachusetts' was very much against the Plan because it potentially destroys the ability for Massachusetts's fishermen to have any substantive commercial fishery in state waters.



DELEGATES VOTE TO OPPOSE STATE TRAP CAP PROPOSAL

The MLA Delegates approved a motion to have the Association oppose any trap tier system proposed by the State. The vote came during the November 13th Delegates meeting following a lengthy discussion on the Division's proposal to establish a statewide Transferable Trap Limit Cap Program based on the average poundage landed by a license holder between 1996 – 2000 (See last month's newsletter).

ELECTION NOTES

The ballot for this year's election of Delegates has been mailed to all paid up voting members and you should be receiving yours right about now. If not, call the office. Please remember to read the instructions carefully and don't forget to return the ballot by December 31st.

You will be selecting those who will guide the policy of the Association for the next two years (2003-2004) – it's your call!!

Nominations for Officers will take place at the first meeting of the new and re-elected Delegates in January 2003 with the actual election of officers taking place in March in accordance with the By-Laws of the Association.

LOBSTER LICENSE RENEWALS & TRAP TAG FORMS

The Division of Marine Fisheries has announced that the 2003 lobster license renewals will be sent out around the first week of December. The 2003 trap tag order forms, however, won't be sent out until at least March. The DMF is waiting to see the catch reports and who doesn't renew before sending out the tag forms. The 2002 tags are valid through May 2003 and the DMF may extend the date through June.

THE MLA "RULER" AS A RENEWAL THANK YOU GIFT

We wanted to send all those who renewed their membership some little thank you gift. Our idea was okay but we couldn't get it successfully through the mail with your new membership card. The envelopes were being destroyed in the postal machines and both the card and ruler were lost. We are trying to get it to you by sneaking it into this newsletter ~ thank you for renewing ~ *Hey, we try!!*

MLA PROMOTIONAL MATERIAL GOES TO ST. LOUIS

MLA lobster promotional material was sent upon request to Midwest Seafood, who is the largest seafood supplier in the St. Louis area. The MLA sent the lobster posters, red and green lobster cut-out cards, bumper stickers and menu insert cards.

CAN YOU DONATE SOMETHING TO OUR AUCTION?

The MLA 2003 Annual Weekend Grand Auction will once again be taking place on Sunday morning, Jan. 26, 2003. As has been the case during the past few years, the auction items are not just fishing-type articles that are always graciously donated by our great exhibitors. Other non-fishing items will be auctioned off as well. We are looking for all types of articles – *well, maybe not your old kitchen sink* - but something you might be willing to donate to the auction. If so, please give **Nancy Reid or Gayle Beaudoin** a call at (781) 545-6984 and they will fill you in on the details. We would like to know by the end of December if possible so that we can properly publicize and display the items prior to the auction. Thank you all very much for your participation.

CASINO NIGHT VOLUNTEERS NEEDED – FOR THE HOUSE

Dave Casoni, who is the coordinator of the Annual Weekend Casino Night, is looking for a few volunteers to help run some of the games, blackjack, wheels, etc. Didn't you always want to be on the "other" side at least just once? Help a good cause and volunteer for a few hours on Friday night, January 24, 2003. Call the MLA office at (781) 545-6984. Thank you very much.

HERRING QUOTA UPDATE

As of November 17th the Sea Herring landings were:

	<u>Total Quota</u>	<u>Taken as of 11/17/02</u>
Area 1A	60,000 mt.	54,620 mt.
Area 1B	10,000 mt.	5,284 mt.
Area 2	50,000 mt.(+70,000 reserve)	10,635 mt.
Area 3	60,000 mt.	14,184 mt.

The regional administrator's office has determined that Area 1A will be closed to all directed herring fishing as of 12:01 AM Sunday, December 1st.

MFC MEETING AND HEARINGS CANCELLED

The November Mass. Marine Fisheries Commission meeting as well as the Public Hearings slated for December were cancelled. The MFC will meet in December and will be discussing what issues may need to go to public hearings probably in January.

PLEASE NOTE: Included in the Notice Section you will find....

- Division of Marine Fisheries Update to ASMFC on Mass. Lobster "Plan".
- NMFS "Whale" Gear Option List Change
- Gas Pipeline (Beverly – Weymouth) Update
- Lobster Institute Bulletin
- Press Release for Robert Delano Martin's Book "The Tale of the Lobster"
- Annual Weekend Registration Forms
- Whale Habitat May Get Bigger – News Article
- MLA Clothing Order Form – Last minute Christmas Ideas !!



THE MLA LEGAL DEFENSE FUND



The Massachusetts Lobstermen's Association continues to need support for its Legal Defense Fund. This dedicated fund has been and will be used for the purpose of defending the Massachusetts lobster fishermen from legal and fisheries management action that could seriously impact our fishermen's ability to conduct their businesses and earn a living.

The Massachusetts lobster industry is facing the possible need for legal action on Lobster Management as well as Federal Right Whale issues. Further down the road there could be Marine Protected Area actions that also may require this Association to respond in a legal format. As we all know, any legal action costs money and this Association needs to be prepared. We certainly would prefer and will continue to try and resolve issues on our fishery without going into court but we must be ready to do so in order to protect our industry and our individual fishermen's livelihoods.

Any contribution you can afford to make to this fund will be held in our legal defense fund and used only for defraying legal expenses if and when they are needed.
Help us, if you can.

A Different Generation

Looking back, it's hard to believe that we have lived as long as we have.

As children we would ride in cars with no seat belts or air bags. Riding in the back of a pickup truck on a warm day was always a special treat.

Our baby cribs were painted with bright colored lead based paint. We often chewed on the crib, ingesting the paint. We had no childproof lids on medicine bottles, doors, or cabinets, and when we rode our bikes we had no helmets. We drank water from the garden hose and not from a bottle.

We would spend hours building our go-carts out of scraps and then rode down the hill, only to find out we forgot the brakes. After running into the bushes a few times we learned to solve the problem.

We would leave home in the morning and play all day, as long as we were back when the streetlights came on. No one was able to reach us all day.

We played dodge ball and sometimes the ball would really hurt.

We ate cupcakes, bread and butter, and drank sugar soda, but we were never overweight. We were always outside playing.

Little League had tryouts, and not everyone made the team. Those who didn't had to learn to deal with disappointment. Some students weren't as smart as others or didn't work hard so they failed a grade and were held back to repeat the same grade.

That generation produced some of the greatest risk-takers and problem solvers. We had the freedom, failure, success and responsibility, and we learned how to deal with it all.

~Author unknown~

DECEMBER 2002 & JANUARY 2003 CALENDAR

12/5	MFC MONTHLY MEETING, DMF ANNISQUAM MARINE LAB, GLOUCESTER	11:00 AM
12/9 (Mon)	BOSTON HARBOR LOBSTERMEN'S ASSN. CHRISTMAS DINNER PARTY RAFFAELLS, NO. QUINCY	7:00 PM
12/12	NORTHWEST ATLANTIC MARINE ALLIANCE (NAMA) BOARD OF TRUSTEES NAMA OFFICE, SACO, MAINE	9:00 AM
12/12	MLA FISHERMEN SERVICES CORP. MTG., MLA BLDG., SCITUATE	8:00 PM
12/16	STELLWAGEN BANK SANCTUARY ADVISORY COUNCIL MEETING GLOUCESTER CITY HALL AUDITORIUM	10:00 – 4:00
12/18	MLA DELEGATES MEETING, SON'S OF ITALY HALL, QUINCY, MA	7:30 PM
12/25	SANTA CLAUS LEAVES TOWN ~ MERRY CHRISTMAS ~	
12/31	MLA ELECTION BALLOTS DUE BACK AT MLA OFFICE	
1/1/2003	HAPPY NEW YEAR!!	
1/6	SO. SHORE LOBSTER FISHERMEN'S ASSN. MTG., OCEAN CAFÉ, BRANT ROCK	6:30 PM
1/8	BOSTON HARBOR LOBSTERMEN'S ASSN., RAFFAELLS, NO. QUINCY	8:00 PM
1/9	MFC MONTHLY MEETING – (LOCATION TBA – CALL DMF 617-626-1528)	
1/9	MLA FISHERMEN SERVICES CORP. MTG., MLA BLDG., SCITUATE	8:00 PM
1/TBA	ASMFC LOBSTER ADVISORY PANEL MTG., WARWICK, RI	
1/15	MLA DELEGATES MEETING (OFFICIAL ANNUAL MEETING) SON'S OF ITALY HALL, QUINCY	7:30 PM
1/16-17	NORTHWEST ATLANTIC MARINE ALLIANCE (NAMA) (TENTATIVE)	
1/21	STELLWAGEN BANK SANCTUARY ADVISORY COUNCIL MEETING – LOCATION TBA	
1/23-26	MLA ANNUAL WEEKEND & LOBSTER TRADE SHOW SEA CREST OCEANFRONT RESORT NO. FAMOUTH, MA GRAND AUCTION SUNDAY 11:00 AM	EXHIBIT HALL HOURS FRI. 9:00 – 6:00 SAT 9:00 – 5:00 SUN 9:00-12:00



ONE CULL OF AN IDEA

Over the past decade lobster fishermen have spent many hours and perhaps days, weeks and months debating what management measures could be used to avoid any serious downslide in the lobster fishery. Placing aside for a minute the argument as to whether anything is needed at all, fishermen working with biologists and managers have discussed all types of ideas and as we now know, we have maximum sizes, minimum size increases, v-notch programs, trap limits, trap reduction programs as well as all types of license limitations. All of these ideas have been explained, studied, debated, assessed, run up and down the hearing flagpole and then fed to the management rulemaking machine.

As one looks back over all the ideas that hit the table, we can recall that some of them were mild and some of them were wild. There was, however, one idea that just never seemed to make it and one might wonder if maybe, just maybe, it deserves another shot.

This idea is the one to conserve and improve the lobster stocks by returning female culls caught while fishing. Now before you brush this one off the table again, think about it. Look at the size rules, the various schemes to cap and cut traps, the tags, the v-notching, the vent increases and the other ideas, which are not all bad but they also all have their own downsides.

As a possible replacement for going with one of the above or as an additional measure if or when one is needed, what about this cull lobster idea? Some of the positive sides to this, it could be argued, could include:

- Culls are generally considered to be a drag on the market and the lobster boat price
- Instead of further reducing the catch of two clawed higher priced, more marketable lobsters, reduce the catch of the less valuable less marketable female culls.
- In this case a cull would be defined as a one-claw or no-claw female lobster. There would, therefore, still be "culls" entering the market for processors or for the meat market but there would be less of them.
- The contribution to the stock, biologically, is quantifiable since there are cull rates in the statistics and the biologists doing their mathematical calculations and extrapolations could assign some level of credit to the management program. It might, in fact, be easier to calculate than some other measures currently in use.

- Fishermen and their sternmen would tend to be more careful when removing lobsters from the traps because a two-clawed female "keeper" could become a throwback if the fisherman wins the tug of war with an obstinate trap-gripping female crustacean.
- Although some biologists have argued that female culls don't produce eggs all that well, other biologists refute that argument. Based on this division, therefore, there is a very good chance that these lobsters, if returned to the sea, will produce eggs, grow larger, regenerate their appendages, and either enter the egger pool or eventually become a valuable keeper lobster. The idea does mean the "removal rate" from the ocean will decrease and that has been what the biologists have said needs to happen. This is also what they complain isn't happening now.
- This measure, like some other ones, would cut across the entire range of fishermen in the area. The big, the small, commercial and recreational, would all be equal in this regard.
- Enforcement would be at the dock or aboard the boat and it would be pretty easy to see. There could be some type of procedure developed to address the measure at the dealer level. It wouldn't be any more complicated to enforce than many of the rules employed in the lobster management program now.

This idea must have had some merit, otherwise the biggest lobster producing country, Canada, would not have entertained this approach for its lobster fishery. Recently, in some Canadian areas, this measure has been selected and approved by the managers. It beat out some other more popular selections such as maximum sizes, minimum size increases, and further trap reductions. Could this idea perhaps be worth further discussion here in our own lobster management areas? Might this be something an Area could consider as a back-up provision or where needed now, an additional measure instead of going back for more of the same old standards?

We are not advocating that this offering necessarily be embraced. We are only saying that it might be worth serious consideration by the Lobster Conservation Management Teams and the management and science communities.

Cull this one out from the pack for another measure.

Bill

Bill Adler, Executive Director

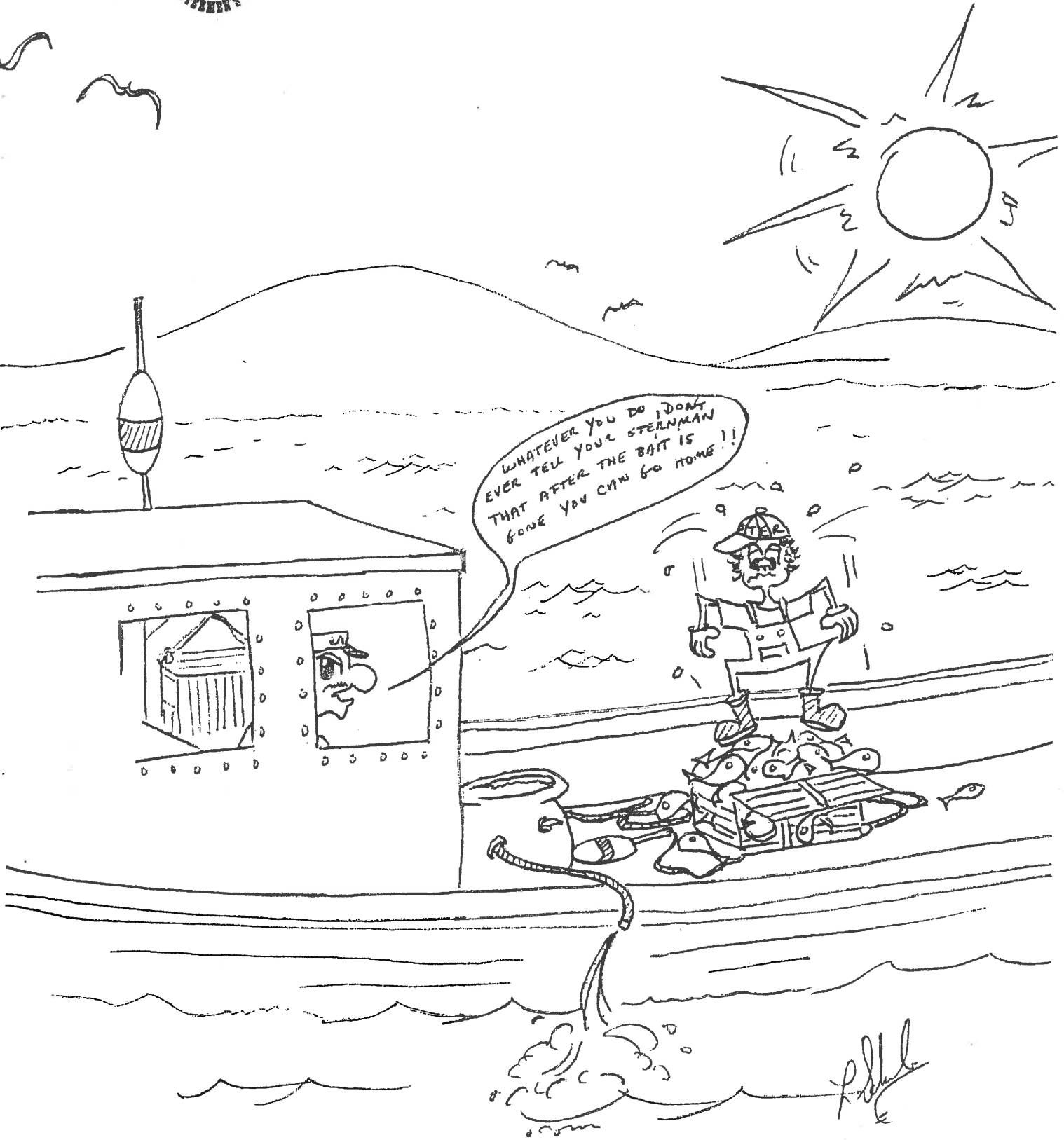

WHATEVER YOU DO, DON'T
EVER TELL YOUR STEERMAN
THAT AFTER THE BAIT IS
GONE YOU CAN GO HOME!!

Handwritten signature

MASS LOBSTERMEN'S ASSOCIATION, INC.
8 OTIS PLACE
SCITUATE, MA 02066-1323



BUS. 781-545-6984
FAX 781-545-7837
E-MAIL mla@lobstermen.com
WEB Site www.lobstermen.com

MEMBERSHIP APPLICATION

Section I TYPE of MEMBERSHIP (check one) Regular* (Voting) \$100 Annual Dues Associate (Non-Voting) \$100 Annual Dues

* To qualify for a Regular Voting Membership, you MUST (1) hold a valid Massachusetts Commercial Lobster License, (2) reside in Massachusetts, (3) be sponsored by either two Regular Members or one Delegate, and (4) send in a copy of your lobster license with this application.

SPONSORS

#1 Name _____
 Delegate Regular Member
#2 Name _____
 Delegate Regular Member

Section II MEMBERSHIP INFORMATION Previous MLA Member? Yes when _____ No

FULL NAME: _____ NICKNAME: _____
ADDRESS: _____
(Street) (PO Box) (City/Town-State) (Zip)
HOME TEL: (_____) _____ CELLULAR: (_____) _____
COMPANY NAME: _____ BUS TEL #: (_____) _____
SPOUSE NAME: _____ E-MAIL: _____
MLA DEATH BENEFICIARY: _____
(Full Name) (Relationship)
BENEFICIARY ADDRESS (if different from above): _____

Section III LICENSE INFORMATION Lobster Permit # _____ State _____ Inshore Offshore
No of Traps _____ Buoy Colors _____
 Finfish Shellfish Seasonal Retired Lobster Dealer Equip. Dealer Other

Section IV BOAT INFORMATION BOAT NAME: F/V _____
 Check here if you would like Hull and/or P & I Insurance Information sent to you. HOME PORT: _____

Section V LOBSTER PRICE/CATCH/MARKET REPORT distributed weekly, available to MLA Members Only
mail or fax: 26 Weeks (\$15) 52 Weeks (\$30) special offer for email: 28 Weeks (\$15) 56 Weeks (\$30)
 Mail to: _____ Fax to: (_____) _____
_____ Email to: _____

How would you like to pay: Check (pay to MLA) MasterCard Visa
Account #: _____ Exp Date: _____
Signature: _____ Date: _____



Paul J. Diodati
Director

Commonwealth of Massachusetts

Division of Marine Fisheries

251 Causeway Street, Suite 400
Boston, Massachusetts 02114

(617) 626-1520
Fax (617) 626-1509



TO: ASMFC Lobster Board

FROM: Paul Diodati, Director

SUBJECT: Massachusetts Lobster Management

DATE: November 15, 2002

Consistent with actions taken at the last meeting of the ASMFC Lobster Board and the subsequent actions taken at the Policy Board, I'm offering an update about the Commonwealth's plans to improve management of American lobster in its waters.

The Policy Board approved the following action, ***"Immediately undertake a process to formulate and prioritize alternative management measures to achieve the egg production targets (equivalent to 100% V-notch compliance at zero tolerance by Massachusetts fishermen in area 1), and submit the alternatives to the Management Board at the ASMFC Annual Meeting in November 2002."***

Since sampling information collected during the 2002 fishing season is not completely processed, the Commonwealth is not able to determine at this time whether or not 100% V-notching took place in Massachusetts' waters. However, we have taken proactive steps to complete evaluation of this information within the next few weeks.

The Commonwealth has begun to formulate and prioritize an alternative management measure to achieve the FMP's Area 1 egg production targets designed to be met under a scenario that requires 100% V-notching at zero tolerance. The alternative measure is embodied in a "Trap Control Plan." The plan has been aired to small focus groups of Massachusetts fishermen, most of whom have served as representatives on the LCMTs; the plan has been described in a recent issue of the popular trade journal, *"Commercial Fisheries News,"* (attached).

Preliminary estimates made by Massachusetts lobster biologists indicate that of the approximate 23,000,000 female lobsters harvested in the Gulf of Maine annually, only about a maximum of 18,000 would be protected through an additional molt if Massachusetts applies the zero tolerance definition in Area 1. Since this is a paper exercise and actual determination of V-notching in the field is very subjective, I believe the numbers of lobsters protected would be substantially lower than 18,000. This is an extremely small amount of added protection. Since there is only very limited conservation value,

An Agency of the Department of Fisheries, Wildlife & Environmental Law Enforcement
David M. Peter, *Commissioner*

I still feel it's wise not to compromise our state's ability to enforce V-notching rules by adding this second definition to our waters.

Notwithstanding, our Trap Control Plan will cap the number of lobster traps fished in waters of the Commonwealth to current levels, about 465,000 traps; within the timelines of the FMP, I anticipate that the plan will cause a reduction of traps of up to 25% statewide. Merely capping the current trap level without reducing it would be a significant measure in itself given the propensity for traps to increase in the fishery as witnessed over the past decade (Figure 1).

We will provide a complete description of our plan to the Lobster Technical Committee to determine its conservation value following completed rounds of public hearings in our state. Given the time needed to complete our public hearing process, to complete our rule-making, and to develop and have available the proper permit materials at the start of the fishing year, we will not be able to launch a new trap control plan prior to the 2004 fishing year.

Figure 1. Annual average traps fished by Massachusetts coastal permits: 1990-2001.

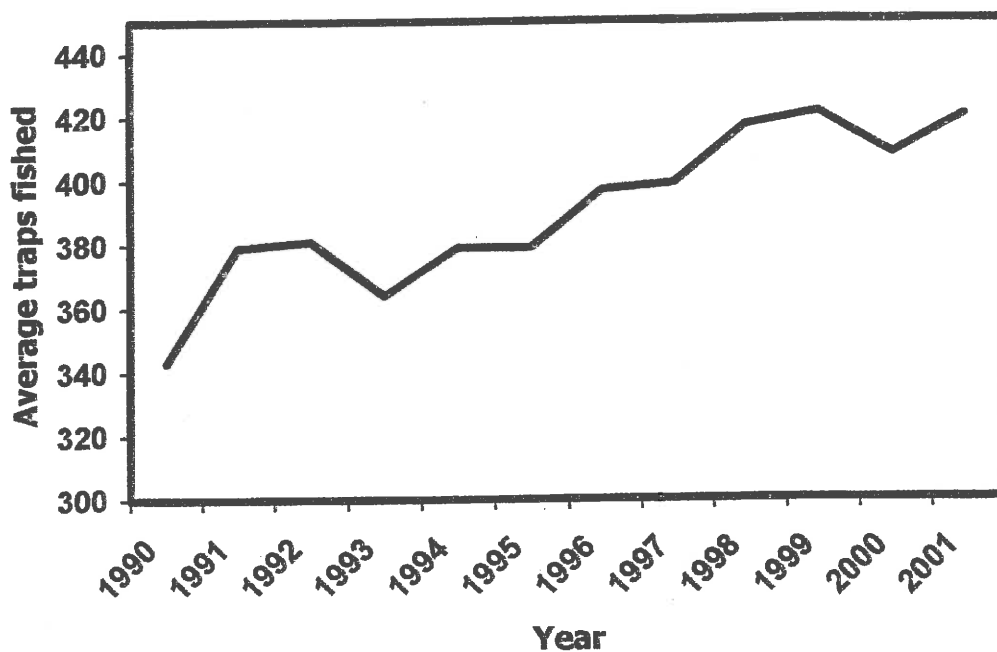

The following article first appeared in *Commercial Fisheries News*, November 2002 and is reprinted with permission.

MA lobstermen react to draft trap limit plan

by Lorelei Stevens

SANDWICH, MA - Wary Massachusetts lobstermen got their first good look at what the Division of Marine Fisheries (DMF) has in mind for a statewide effort control program during public meetings in Gloucester and Sandwich in mid-October.

DMF is developing a tier system plan to tie the number of traps a lobsterman can fish to the number of pounds he reported landing within a certain time frame and to restrict the number of traps transferred with each permit.

The plan is far from finalized, but the idea, according to DMF Director Paul Diodati, is to cap the number of traps in state waters at a little under 500,000 and to reduce that number over time to protect the lobster resource and the future economic value of the industry to the state.

While agreeing that there might be some merit to a trap cap plan, many of those who attended the meetings had serious trouble with parts of DMF's draft proposal.

Some also questioned why the state thought it could do a better job at solving complex problems that the Atlantic States Marine Fisheries Commission (ASMFC) Lobster Conservation Management Teams (LCMTs) have wrestled with for years.

"I don't understand going with a plan developed over a few weeks or months that took the LCMTs six years," said Boston Harbor lobsterman Bill Doherty, who attended the Oct. 10 meeting in Sandwich. "Fall River isn't Boston Harbor."

One trap plan

Under the ASMFC interstate lobster plan, lobstermen from four different areas -- Area 1, Area 2, Outer Cape Cod, and Area 3 -- land in Massachusetts.

Diodati announced earlier this year that DMF would not simply adopt the vastly different area management plans. He argued that administration of the plans would be too complicated and expressed serious doubts that the plans, particularly the one in Area 1, would adequately protect the lobster resource from eventual overharvest.

Instead, while DMF has implemented or is about to implement most of the components of the area management plans already approved by ASMFC, it has held off on some, including the Outer Cape trap reduction plan.

"My feeling is that you need to have uniform effort control with one entity (DMF) controlling effort," Diodati said. "My job is to look at the situation and give the best recommendation for the commonwealth of Massachusetts, not for Maine."

What about ASMFC?

How the DMF plan will mesh with the LCMT plans governing state waters fishing activities of lobstermen who land in Massachusetts was one of the big questions on everyone's mind.

Frustrated Outer Cape lobstermen predicted that their carefully crafted LCMT plan will fall apart unless the area's trap reduction program goes into effect soon since new effort is already flooding into the area.

"You're trying to do one-size-fits-all. We have a problem with that," said one. "If we get any more than 30,000 traps in the Outer Cape area, we'll need to come up with something else" to meet ASMFC egg production goals.

Do limits count?

And, according to a number of LCMT members, ASMFC biologists have made it clear that trap numbers in some areas, particularly Area 1, would have to be reduced dramatically to contribute anything to egg production goals.

"The scientists have already told us that in Area 1, the numbers would have to be so low that no one would be in business. We've beaten that to death," said Gary Ostrom, an Area 1 LCMT member who fishes out of Sandwich.

In other words, a Massachusetts trap cap plan might require many lobstermen to give up traps, yet might not gain them anything in terms of conservation credit under the interstate lobster management program.

But Diodati, who is no stranger to stirring up controversy at ASMFC, stressed that he would do everything possible to convince the interstate commission that the Massachusetts plan provides important and effective conservation support.

"As far as I can see, this is the most responsible lobster management plan in the country," he said of the DMF draft. "I would argue that we should get egg production credit."

Four tiers

The draft plan Diodati described would establish four "tiers" based on the average of a permit holder's landings over a five-year period.

In his example, Diodati explained that the lowest tier would apply to someone whose average landings over that five-year period were, say, from 1 pound to 2,999 pounds. People in this category would get 150 traps.

The highest tier would be for those whose average was, say, 300,000 pounds. People in this category would get 650 traps in state waters -- 150 less than the current state maximum and a figure that many lobstermen in Sandwich said would not sustain their businesses.

"If we were to cut back to 650 traps, it would disadvantage us. We would have problems getting help," said Henry Cebula of Fairhaven.

"When the lobsters are here, we need three sets of gear," he said, explaining that the lobsters hauled on days one and two cover expenses. "It's the third day that makes the business profitable."

Added Boston Harbor lobsterman Bernie Feeney, "And those lobsters are in that bin because of 800 traps."

Finding a way

But Diodati tried to explain that he believed those lobstermen who are truly dependent on 800 traps could be accommodated through an appeals process that would allow allocation of additional traps.

The extra traps would likely come from the lowest tier because people in that category whose average landings were 1,000 pounds or less -- about half of that tier's 780 permit holders -- would not be allowed to transfer their traps.

"I suspect that once you create a program like this, it won't make sense for those people to hold onto their permits," he said because of the \$260 annual license fee.

But the idea was still far too uncertain to reassure the lobstermen.

Alternatives

Those who attended the Sandwich meeting offered numerous alternative ideas, including the following.

> **Allow consolidation** -- "Consider putting two permits on a boat. The only way you'll be able to survive is with father/son operations or two partners on a boat," said Ostrom. Others suggested giving consolidated operations 1,200 traps rather than the 1,600 that would be derived from twice the 800 maximum.

> **Impose a uniform reduction** -- "Take 10% away from everyone," said Feeney. "I'll fish 720 traps if the guy next to me (with 400) will take 360."

> **Cap transfers** -- Several lobstermen pointed out that limited entry in the fishery has resulted in a huge bubble of older men who will be retiring from the business over the next five to 10 years. This alone could lead to a significant trap reduction over the long term. Or

> **Set up a lottery system** -- Feeney suggested that traps from retired licenses be split up with half being retired and half going into a lottery to allow those still in the fishery to grow their businesses. "If you win the lottery one year, you wouldn't be allowed to participate in the lottery for a few years," he proposed.

The lobstermen also voiced serious concern about the ability of the state to effectively enforce *any* trap limit and about the tremendous proliferation of traps under the 10-pot recreational permit.

One way or another

In summing up the Sandwich meeting, Diodati made it clear that the draft plan was not set in stone and that he had every intention of taking lobstermen's ideas into account.

"What I'm hearing is 800 rather than 650 and consolidating permits. We'll look at it," he said, adding that he wanted to meet with industry people again in a few weeks.

At the same time, he also said that he intends to go forward with some kind of statewide effort control plan one way or another.

"Keep in mind that by next season -- by July -- there will be changes for somebody," Diodati said. "Ten years down the road, I think we'll all be more profitable." n



UNITED STATES DEPARTMENT OF COMMERCE
National Oceanic and Atmospheric Administration
NATIONAL MARINE FISHERIES SERVICE
NORTHEAST REGION
One Blackburn Drive
Gloucester, MA 01930-2298

OCT 17 2002

Dear Commercial Lobster Trap/Pot Fisherman:

This letter is to remind commercial lobster trap fishermen in Northern Inshore State Lobster Waters that one of the options on the Atlantic Large Whale Take Reduction Plan's (ALWTRP) Lobster Take Reduction Technology List expires December 31, 2002. Earlier this year, the National Marine Fisheries Service (NOAA Fisheries) sent a permit holder letter to commercial lobster trap fishermen on the recent amendments to the regulations implementing the ALWTRP. One of these amendments included a change to the Lobster Take Reduction Technology List which affects lobster trap fishermen in Northern Inshore State Lobster Waters. A detailed summary of the requirements for these waters is provided below.

Does this amendment to the Lobster Take Reduction Technology List apply to me?

This amendment applies to fishermen who use lobster trap/pot gear in the state waters of Rhode Island, Massachusetts, New Hampshire, and Maine but does not include waters landward of the first bridge over any embayment, harbor, or inlet and waters landward of the following areas in Rhode Island: Sakonnet River, Narragansett Bay, Pt. Judith Pond Inlet, Ninigret Pond Inlet, Quonochontaug Pond Inlet, and Weekapaug Pond Inlet (see Figure 1 for Northern Inshore State Lobster Waters Area depiction).

What do I have to do to comply with this amendment?

Between now and December 31, 2002, fishermen with lobster trap gear in the Northern Inshore State Lobster Waters Area must be in compliance with one option out of Options 1-4 from the Lobster Take Reduction Technology List (see below). Starting January 1, 2003, fishermen must be in compliance with one option out of Options 1-3.

Lobster Take Reduction Technology List:

- Option 1. All buoy lines must be composed entirely of sinking and/or neutrally buoyant line.
- Option 2. All ground lines must be composed entirely of sinking and/or neutrally buoyant line.
- Option 3. All buoys must be attached to the buoy line with a weak link having a breaking strength no greater than 600 lbs (272.4 kg). Weak links may include swivels, plastic weak links, rope of the appropriate breaking strength, hog rings, rope stapled to a buoy stick, or devices approved in writing by the NOAA Fisheries Assistant Administrator. In addition, the bitter end of the buoy line must be clean and free of knots when the weak link breaks.
- Option 4. All buoy lines must be 7/16 in (1.11 cm) or less in diameter. (Effective January 1, 2003, the Lobster Take Reduction Technology List will be amended to remove this option. Removing this option from the Lobster Take Reduction Technology List does not prevent a fisherman from continuing to use buoy line with a diameter of 7/16 in (1.11 cm) or less. However, it can not be counted as an option from this list.)



Please note that lobster trap fishermen must also comply with the universal gear requirements, which include: 1) no wet storage of gear, 2) no floating line at the surface, and 3) fishermen are encouraged, but not required, to maintain knot-free buoy lines.

This letter only summarizes some of the requirements for Northern Inshore State Lobster Waters. To obtain the regulations in their entirety, please call 978-281-9328. In addition, these regulations are available by accessing the ALWTRP web page (www.nero.nmfs.gov/whaletrp/). If you have any questions regarding these regulations, please call 978-281-9328.

Sincerely,

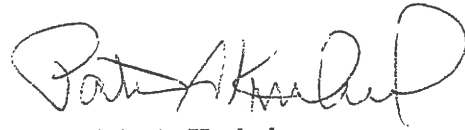
A handwritten signature in black ink, appearing to read "Patricia A. Kurkul". The signature is fluid and cursive, with the first name "Patricia" being more prominent than the last name "Kurul".

Patricia A. Kurkul
Regional Administrator

Enclosure

Figure 1

ALWTRP Regulated Lobster Waters

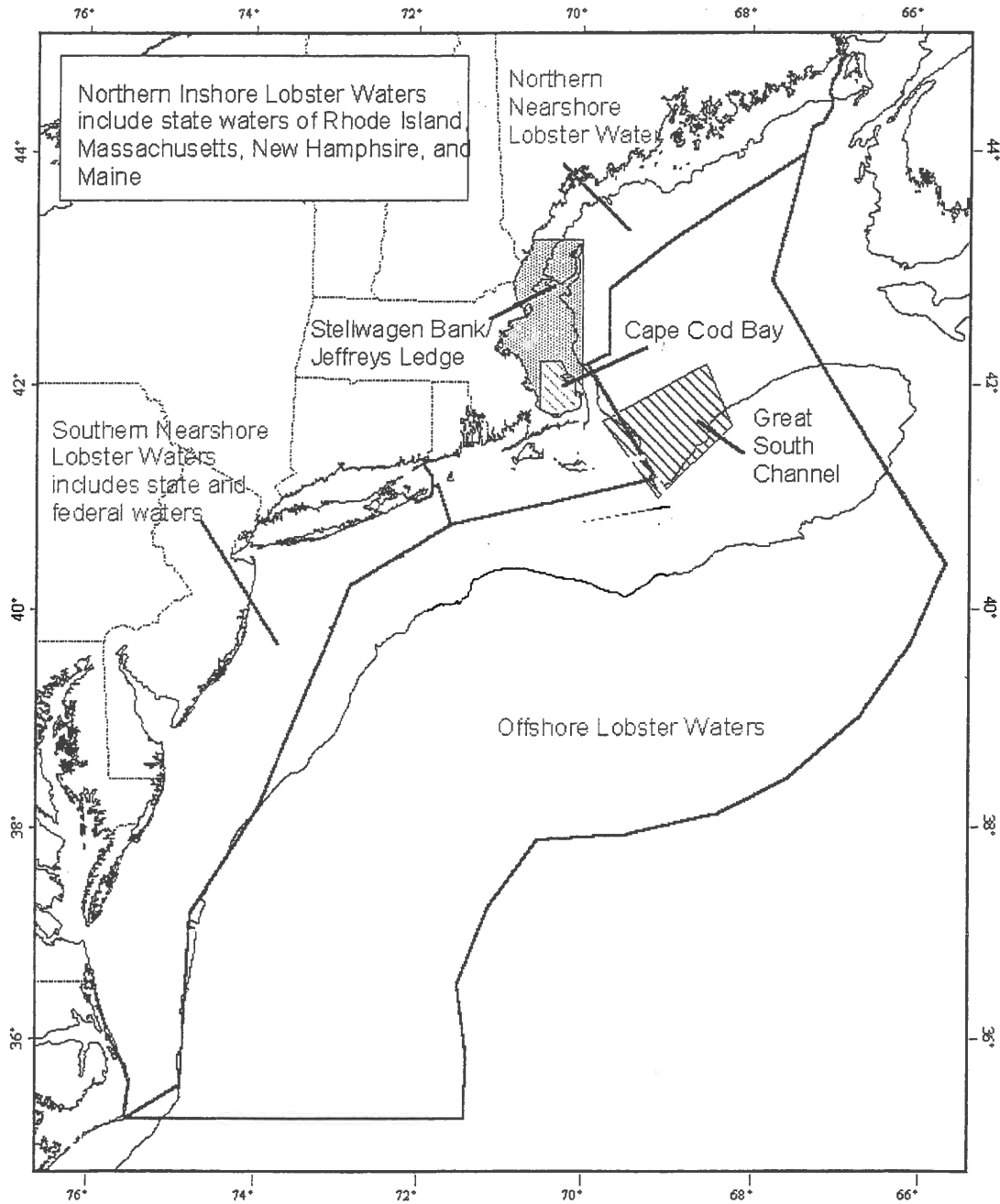

HubLine Project – Construction Update

December 2002

Algonquin Gas Transmission Company's ("Algonquin") HubLine Project is a 29.02-mile, 30-inch diameter interstate natural gas pipeline that will be built offshore from Salem to Weymouth, Massachusetts. Algonquin began the initial phases of the construction of its HubLine Project in late September and October.

HubLine has set up a project website (www.hublineupdates.com and www.hublineproject.com) to provide regular updates concerning the locations of pipeline construction. The general route map for the HubLine Project appears on the following pages. The map has been updated to include the approximate widths along the route where construction activity, including anchor spreads or environmental surveys, will occur throughout the construction period. The black line represents the centerline of the pipeline, while the area of potential construction activity is denoted by dotted lines to either side. A similar map, updated daily to highlight ongoing construction activities, is also provided on the Project website under "Updates". In addition, HubLine has placed buoys in the ocean along the actual route to indicate the project corridor. Yellow buoys mark the western edge of the construction activity area and pink buoys mark the eastern edge.

HubLine is broadcasting construction updates each day on local marine channels. Project information is also made available to groups such as the U.S. Coast Guard and local harbor masters. The U.S. Coast Guard will broadcast this information as part of its daily Broadcast Notification to Mariners on channel 16 (156.8 Mhz). Algonquin will also provide twice daily construction updates on the marine channels listed on the table shown on the next page as offshore construction advances.

The overall construction schedule is as follows. The majority of construction activities, including pipelay and conventional bucket dredging, proposed in the near shore areas (i.e., water depths less than 20 feet) will begin in December and extend until March 15, 2003. The deepwater (i.e., greater than 20 feet) plowing and pipe laying activities are also expected to start in December and continue with final backfilling completed by May 1, 2003. The decision to construct the offshore portions of the HubLine Project during the winter months was a direct result of the Project's discussions with the Massachusetts Lobstermen's Association (the "MLA"). Although the majority of construction activities were not scheduled to begin until November, some limited survey activities, including diving operations, began in late August. In addition, beginning in late September and continuing through the winter, the HubLine Project is using the horizontal directional drill ("HDD") technique in certain near shore areas in order to reduce the impact to important resource areas. These near shore areas include Beverly Harbor, the Weymouth Fore River and Georges Island. Some short segments of the pipeline route also saw localized activity such as barge mooring in support of the HDDs before offshore construction began.

Blasting activities in a limited number of areas will also precede general construction activities, starting in late November. The Coast Guard Captain of the Port has created a safety and security zone for drilling and blasting operations around Drillboat No. 8 and Lablift IV. The safety and security zones will be from 400 to 600 yards around these two vessels when explosives are on board, and will include one hour prior to, during, and one hour after all blasting operations. A Safety Marine Information Broadcast will be made during drilling and blasting operations.

The MLA also asked HubLine to put together a summary of the vessels that will be used and the types of activities that they will support. That information is summarized below. Please note that the dates listed are approximations and are dependent on a number of factors, including weather.

1. Drill 8 – Blasting Vessel in less than 60 fsw

- This vessel is scheduled to perform blasting operations at blast sites B, C and D starting late November. These sites are located to the east/southeast of Cat Island and to the west of Satan Rock, approximately located at Project Milepost 5.
- The duration of this activity is approximately 1 to 2 weeks, pending weather, through mid December.
- This vessel will transit to other blast locations, as necessary.

2. Dredge 53 – Interrogation of blast sites in less than 60 fsw.

- This vessel is currently interrogating blast site E, just north of Project MP 11.
- The vessel will continue interrogating the remaining blasting locations in this water depth. Specifically, sites X1 (MP 11), X2 (MP 11.25), and site G (MP 14.75).

3. Dredge 51 - Interrogation of blast sites in greater than 60 fsw

- This vessel is currently interrogating blast sites along the pipeline route east of Great Brewster Island and Calf Island. There are 4 locations along this segment of the route that need to be investigated to determine the exact depth of the bedrock.
- Upon completion of this activity, the vessel will commence pipeline trenching activities required along the Weymouth Fore River channel. The dredging activities are currently planned to start at MP 26R and continue in a southerly direction along the proposed route. The duration of this activity is estimated to extend through December.

4. American Star (ROV/Dive Vessel) – Obstructions Relocation/Removal

- This vessel is currently performing investigations of various obstructions along the entire pipeline route. There is diving associated with this activity. Once an obstruction has been located, the vessel will anchor over

this location and send divers down to assess the situation. Once the object has been relocated off of the pipeline route, the vessel will transit to the next location.

- Upon completion of the above task, the vessel will commence preparation of the pre-lay crossing preparation of the foreign utilities being crossed by the pipeline. Specifically the 360 networks fiber optic cable near MP 10.4 and the 60" easterly sewer outfall near MP 25R will be involved.
- This vessel will perform utility crossing work at MP 25.5 associated with the MDC 6" water line between Peddock's Island and Nut Island.

5. DB 801 – Offshore Lay Vessel (OLB)

- This vessel is currently mobilizing from the Gulf of Mexico. ETA is mid to late December.
- The vessel will commence pipe lay activities from the north side of Georges Island and head in a northerly direction.

6. Midnight Rider – Shallow Water Lay Barge (SWLB)

- This vessel is also mobilizing from the Gulf of Mexico. ETA for this vessel is late December.
- The vessel will commence pipe lay activities in the shallow water in the Weymouth Fore River area.

7. DB Boaz – Offshore Bury Barge

- This vessel will arrive on location in January.
- This vessel will perform the plowing activities following the DB 801.

8. Weymouth Horizontal Directional Drill (HDD)

- A jack-up vessel has been positioned at the Weymouth HDD exit location to perform the remaining horizontal direction drill work taking place in Weymouth.
- The jack-up shall remain on location until the drilling has been completed. The current schedule shows completion of drilling around mid to late December.

9. Salem HDD

- A jack-up vessel will also be positioned at the Salem HDD exit location in approximately 2 – 3 weeks and will remain at this location for 4 to 6 weeks, or until late January.

10. Beverly HDD

- A third Jack-up vessel will be positioned on the Northeast side of the Beverly Channel to commence installation of the Beverly HDD. This vessel is currently in transit and should arrive by mid December.
- Once on location, the estimated duration of this activity is 3 - 4 months.

The current activities described for the above vessels are subject to change due to weather and/or any other unforeseen occurrences. Please refer to the project website for up-to-date information.

Please use the information sources discussed above to follow the progress being made by the HubLine Project during construction. Algonquin has also designated Mark McConnell as the Issues Resolution Coordinator for Algonquin's 24-hour Landowner Hotline. If individual questions arise, Algonquin would urge you to contact Mark toll-free at 1-888-367-7005. Mark or a Project representative will respond to your call as soon as practicable, but in any event within 48 hours.

Lobstermen Information		
Location/Area	Channel Broadcast Operation	Notification Timetable
Beverly, Salem and Marblehead	Channel 6 and 19	7:00 AM & 12 Noon Daily
Swampscott, Lynn and Nahant	Channel 80	7:00 AM & 12 Noon Daily
Deer Island Lateral	Channel 79	7:00 AM & 12 Noon Daily
Lovell Island to Deer Island Tap	Channels 77 and 79	7:00 AM & 12 Noon Daily
Lovell Island (south) to Weymouth	Channels 65 and 77	7:00 AM & 12 Noon Daily

SALEM AND LYNN HARBORS



LISTED UNDER - SAIT FERRY
MARINE INFRASTRUCTURE
SALEM AND LYNN HARBORS
MARINE INFRASTRUCTURE
AT SALEM, MASSACHUSETTS

HUBLINE MAINLINE - MILEPOST LOCATIONS				
MP	LAT.	LONG.	LORAN C (TIME/DISTANCE)	
			9960-W	9960-Y
0.33	42° 32.227'	70° 52.859'	13934.31	44341.63
1	42° 32.467'	70° 52.148'	13928.46	44341.59
2	42° 32.498'	70° 50.993'	13920.84	44339.57
3	42° 32.269'	70° 49.894'	13914.84	44336.22
4	42° 31.510'	70° 49.303'	13914.90	44330.93
5	42° 30.887'	70° 48.511'	13912.98	44326.00
6	42° 30.302'	70° 47.661'	13910.49	44321.18
7	42° 29.838'	70° 46.665'	13906.57	44316.78
8	42° 29.033'	70° 46.636'	13910.37	44312.25
9	42° 28.248'	70° 47.116'	13917.46	44308.78
10	42° 27.708'	70° 48.034'	13926.11	44307.50
11	42° 27.120'	70° 48.899'	13934.65	44305.84
12	42° 26.533'	70° 49.764'	13943.19	44304.16
13	42° 25.945'	70° 50.629'	13951.72	44302.49
14	42° 25.358'	70° 51.494'	13960.25	44300.80
15	42° 24.713'	70° 52.281'	13968.54	44298.64
16	42° 23.873'	70° 52.437'	13973.74	44294.18
17	42° 23.017'	70° 52.571'	13978.83	44289.57
18	42° 22.184'	70° 52.909'	13985.13	44285.46
19	42° 21.437'	70° 53.483'	13992.51	44282.26
20	42° 20.780'	70° 54.241'	14000.63	44279.91
21	42° 20.045'	70° 54.831'	14008.02	44276.79
22	42° 19.273'	70° 55.413'	14015.54	44273.42
23	42° 18.641'	70° 56.165'	14023.46	44271.17
24	42° 18.093'	70° 57.069'	14031.94	44269.68
25	42° 17.262'	70° 57.226'	14036.95	44265.13
26	42° 16.674'	70° 56.524'	14035.25	44260.41
27	42° 15.888'	70° 56.284'	14037.47	44255.39
28	42° 15.212'	70° 57.058'	14045.69	44252.86

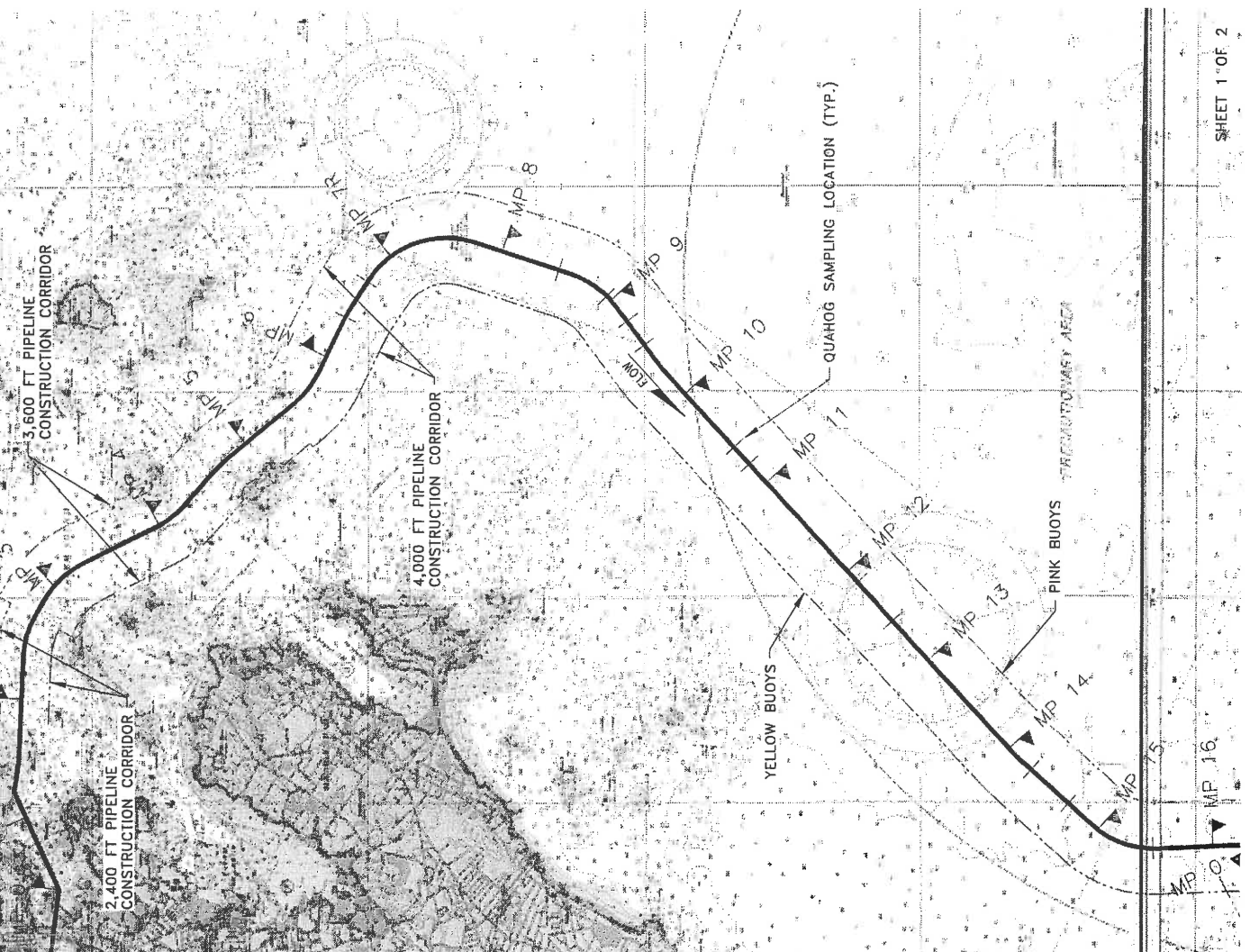

24 - HOUR HOTLINE
 (888) 367-7005
 WWW.HUBLINEPROJECT.COM

HUBLINE PIPELINE PROJECT

DEER ISLAND LATERAL - MILEPOST LOCATIONS		
MP	LAT.	LONG.
0	42° 23.575'	70° 52.437'
1	42° 23.161'	70° 53.468'
2	42° 22.747'	70° 54.499'
3	42° 22.278'	70° 55.485'
4	42° 21.822'	70° 56.481'
5	42° 21.411'	70° 57.514'

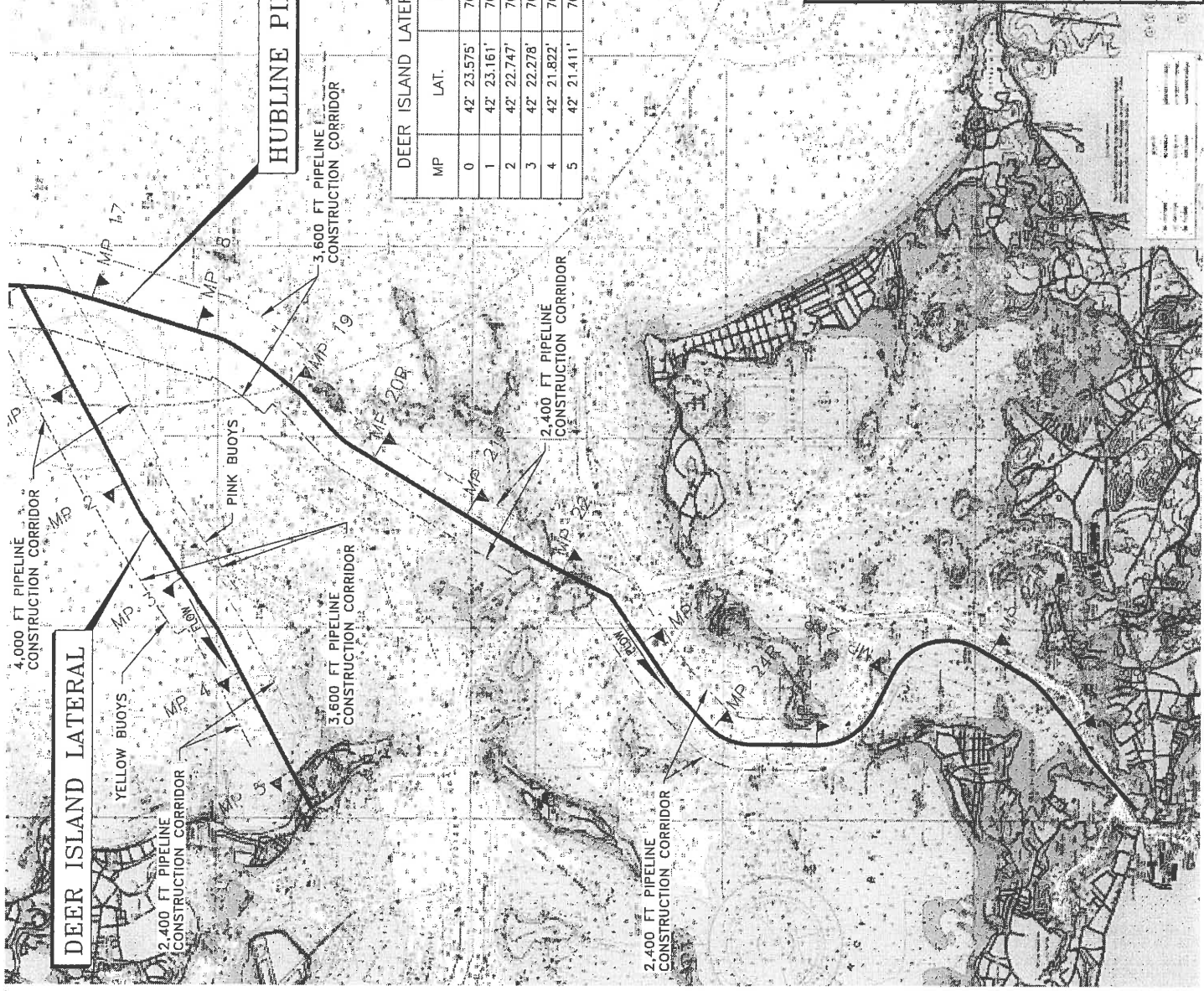

NOTES:

1. GEODETIC INFORMATION BASED UPON MASSACHUSETTS STATE PLANE COORDINATE SYSTEM, ZONE 2001, NORTH AMERICAN DATUM 1983.
2. MILEPOST LOCATIONS ARE FOR REFERENCE ONLY AND SHOULD NOT BE USED TO DETERMINE PIPELINE ROUTE LENGTH.



Duke Energy Gas Transmission
 Algonquin Gas Transmission Company
 1294 Soldiers Field Road, Boston, MA 02135 (617) 254-4000

HUBLINE PIPELINE PROJECT
 MILEPOST AND CORRIDOR MAP

DRAWN BY: S.E.M. CHK'D. BY: R.P.G.

DATE: 11-11-02 APPRV. BY: L.E.P.

DWG. NO. MP-MAP REV D

HUBLINE PROJECT BLASTING OPERATIONS SAFETY AND SECURITY ZONES

As part of the Hubline Gas Pipeline Project, the Coast Guard Captain of the Port has created a safety and security zone for drilling and blasting operations around the DRILLBOAT NO. 8 and LABLIFT IV. These vessels will be conducting drilling and blasting operations along the Massachusetts coastline from Salem to Quincy, MA.

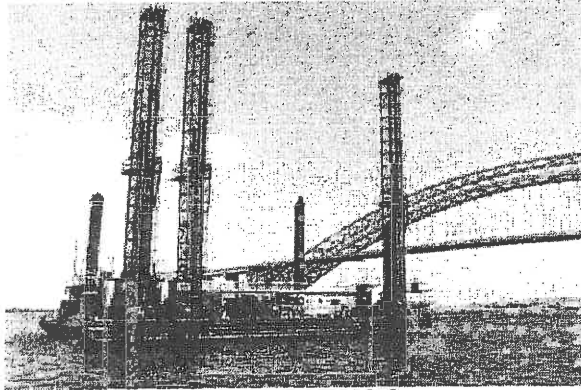

DRILLBOAT NO.8

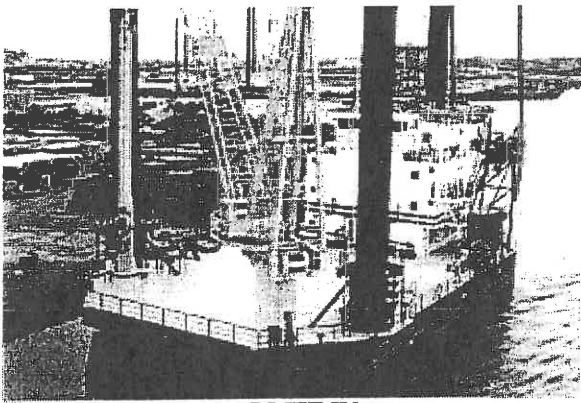

LABLIFT IV

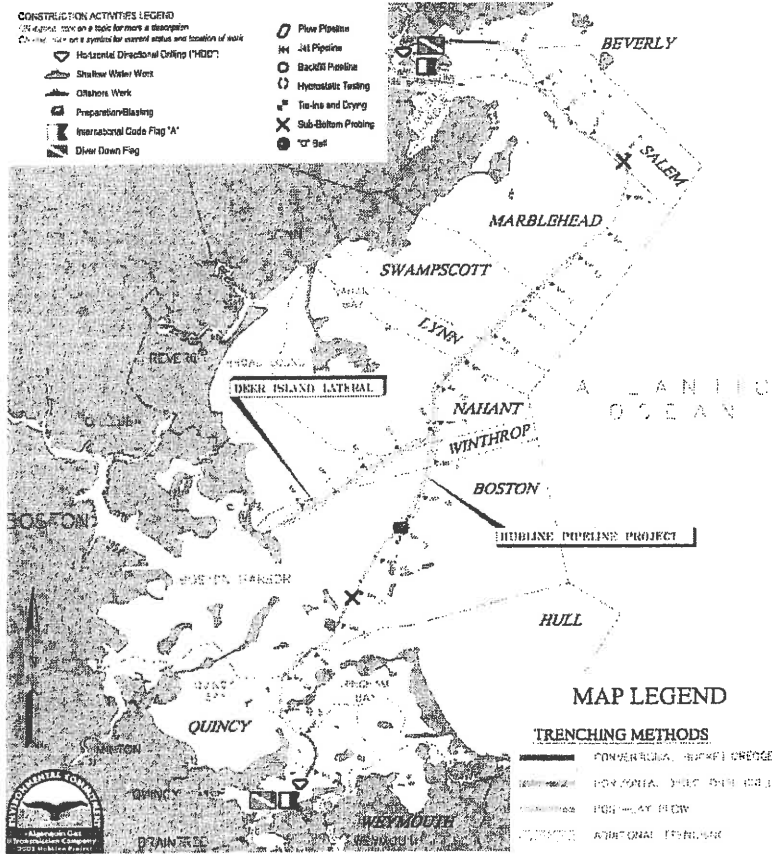

The safety and security zone will be 400 yards around the DRILLBOAT NO. 8 and LABLIFT IV while operating in Danvers, MA, the Danvers River, Salem Sound, Broad Sound, Nantasket Roads, Quincy Bay and Weymouth Fore River to Quincy, MA, Boston Harbor, or any location the vessels may have to shelter in emergency situations.

During Blast Operations the safety and security zone extends to 600 yards around the vessels DRILLBOAT NO.8 AND LABLIFT IV one hour prior to, during, and one hour after all blasting operations.

The safety and security zones are in effect only when explosives are on board the DRILLBOAT NO.8 and LABLIFT IV or when loading and unloading operations are in progress at Conley Marine Terminal. These zones are effective from 12:00 a.m. November 18, 2002 through 11:59 p.m. February 28, 2002.

A Safety Marine Information Broadcast will be made during drilling and blasting operations. Information will also be available in the Local Notice to mariners and on the Web at www.hublineproject.com including daily project updates and equipment positions.

"News, research updates, and information on lobsters and the lobster industry."

Published by the Lobster Institute

"Protecting and conserving the lobster, and enhancing lobstering as an industry...and a way of life."

Educational Programs a Big Part of Lobster Institute's Summer Activities

The Lobster Institute provided a number of educational programs throughout this past summer. Most notably, the Institute hosted its second Lobster College – a learning vacation where folks spend a long weekend on the coast of Maine and are immersed in learning everything there is to know about the lobster industry. Lobster College students came from as far away as California and Arizona to learn about lobster biology, cuisine, history, and other related topics. Also part of the curriculum were field trips to a working lobster wharf and a lobster boat excursion. The event was well received by all. As one participant wrote, "The words great and excellent are much overused in our society, but these words must be used to describe this program."

Other educational activities included presentations for a conference of economics educators; a lecture as part of Downeast Senior College; talks at a variety of community lecture series; participation in the LFA 34 lobster workshop in Nova Scotia; and the Institute's own annual Friends of the Lobster Institute luncheon.

Organizations or schools interested in contacting the Lobster Institute about presentations can call Cathy Billings at 207-581-2751.



Dr. Bob Bayer displays a blue lobster at the annual Friends of the Lobster Institute luncheon held in August at Tidal Falls. The lobster, "Old Blue", was donated to the Institute by Jim Stone, a lobsterman from Rockland, Maine.

Lobster Institute Helps Bring Wood Composite Trap Runners to the Market

With help from a Maine Technology Institute Seed Grant in the Fall of 2001, the Lobster Institute and the University of Maine's Advanced Engineered Wood Composite Center developed a prototype lobster trap runner made of wood composite materials. The composite is a formula of wood, sawdust, and plastic polymer. The material is not susceptible to rot or invasion by ship worms.

Bob Brown of Sealure North American, LLC distributed the prototype trap runners to lobstermen and also installed and tested the runners on his own traps. After some modifications, the concept was picked up by CorrectDeck of Biddeford, Maine who now produce the runners for the commercial market.

According to CorrectDeck, the runners have a 1.2 specific gravity, allowing them to sink in water while using less weight in traps as compared to traditional runners. The composite material used by CorrectDeck has a moisture absorption rate of less than 1% and a 50-year lifetime. Plante's Lobster Escape Vents, Inc. of Somerville, Maine, is distributing the runners. ❄

The **Lobster Bulletin** is published by the



LOBSTER INSTITUTE

5763 Rogers Hall, Room #210
The University of Maine, Orono, ME 04469-5763
Phone: 207-581-2751 Fax: 207-581-2744
www.lobsterinstitute.org

A unit of the Maine Agricultural & Forest Experiment Station



A member of the University of Maine System

Cathy Billings, Editor cathy.billings@umit.maine.edu

POINT – COUNTERPOINT: Opposing Editorials on the Use of Quotas as a Management Tool in the Lobster Fishery.

The *Lobster Bulletin* will feature opposing editorials discussing the use of quotas as a management tool in the lobster fishery – one in the Fall 2002 issue and one in the Winter 2003 issue. By luck of the draw the editorial in this Fall 2002 issue is an opinion opposing quotas, offered by Wayne Spinney, a lobsterman from Nova Scotia. Our next issue, Winter 2003, will feature an opinion in favor of quotas offered by Dick Allen, a lobsterman from Rhode Island. Please note that editorial commentary does not necessarily reflect the views of the Lobster Institute. We invite reader feedback.

Quota Management System Will Be Destructive to Lobster Fishery

Editorial comment by

*L. Wayne Spinney, Lobster Fisherman
L.F.A.34, South West Nova Scotia, Canada.*

At a recent workshop on Oct.1st and 2nd held in Yarmouth, Nova Scotia, the inshore lobster harvesters and their representatives notified Mr. Neil Bellefontaine, Regional Director General of the Canadian Department of Fisheries and Oceans (DFO), that they are again unanimous in opposing the use of 'quota' and or 'transferable tags' as tools for conservation or management in the lobster industry. To implement 'quota' as a management tool while witnessing catastrophes for years in other fisheries governed with this mechanism is inexplicable.

Thousands of maritime families can testify to the devastation and horror resulting from poor fisheries management since the implementation of the quota system. A system made to look very enticing by large initial individual quota allocations. Each year thereafter the inshore fleet faced quota allocation cuts that forced many fish harvesters out of the industry. Larger companies purchased and stockpiled quota or 'paper fish.' This caused quota prices to increase to the level that owner/operators could not afford enough quota to make their enterprise viable. 'Paper fish' exchanged or auctioned off became only affordable to corporate fleet owners.

In hindsight, the set up for the destruction of a fleet and the demise of a fish species is obvious as a result of a 'quota' management system. The same strategy has been used species by species here in Canada. The herring, cod, haddock, pollock, flounder and the scallop fishery all followed similar patterns of ruin. Are we to allow our lobster industry to be next?

The traditional inshore fishery is an economic system where most vessels support three or more families. Documented proof shows that profits stay in the communities and region. Indirect jobs are created both locally and in other provinces through supplies and services required to maintain the fleet and the families

employed within the industry. Most corporations export profits from the region and from Canada.

In addition, the current pay for lobster crewmembers average between 12% to 15% of gross catch, even as the industry is hit with increasing costs and user fees. This differs from a corporate owned vessel where a crew's pay may be only 1% to 3% of gross catch.

The corporate goal is vertical integration of the fisheries. This means huge companies own the quota, vessel, captain, crew, processing plant, etc. The argument that 50 corporate lobster vessels in L.F.A. 34 would be more economically efficient than the inshore fleet of nearly 970 vessels is ludicrous. This corporate fleet will be smaller in numbers only. They will be fishing year round, using any amount of gear as determined by the owner. This non-conservation quota system will increase effort as witnessed in other fisheries.

The present management practice has proven to work for sustainable conservation in the inshore lobster fishery for decades. A seasonal lobster fishery allows the lobsters to molt, to mate, to spawn, etc. Other conservation measures in place include: limited number of traps per license, restricted trap size, minimum carapace size, minimum size escape hatches, v-notching of berried lobsters, and the presence of conservation officers, etc. These conservation tools exceed lobster conservation requirements if proper enforcement is in place. We have been and continue to be true stewards of a renewable resource ensuring a fishery for future generations of families living in coastal communities. ☼



**Check out the Lobster Institute website at
www.lobster.um.maine.edu/lobster ---
providing the definitive site for lobster information
.....with nearly 200 links.**



Readers may contact the Lobster Institute for more detailed information on any of the projects reported.

- ❖ **Audio Recordings of Lobsters** – Dr. Bob Bayer of the Lobster Institute, and Rob Rosenthal of Shunpike Audio in South Portland Maine have been attempting to record any sounds emitted by lobsters held in tanks by using a hydrophone. To-date, no sounds have been heard.

The spiny lobster, which does not have the large claws of the American lobster, does emit a raspy sound that is thought to be a defense mechanism.

- ❖ **Lobster Cam Goes Dark Again** – The Lobster Institute's Lobster Cam was up and running again this summer for just two days before once again going dark. Lobster Cam is an underwater camera mounted inside a lobster trap that provides real-time video viewing via the Internet. Earlier in the year the camera's mounting brackets rusted out and the camera was dark for several months while a student researcher worked on developing a new system to secure the camera to the trap. When that work was completed, the trap and camera were re-submerged in Rockland Harbor, Maine. Within two short days the video again went dark and it was discovered the camera needed to be replaced. The Lobster Institute and the Internet provider for Lobster Cam, MidCoast Internet Solutions, are searching for a replacement camera. Sealure North American, LLC is a sponsor of Lobster Cam, which can be found via the Lobster Institute's website at www.lobsterinstitute.org. Archived shots from Lobster Cam are also available for viewing on the site.

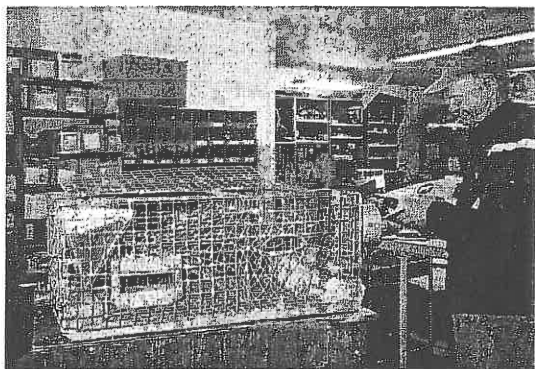

Dr. John Riley, a Lobster Institute cooperating research professor, works on repairing the fittings for Lobster Cam prior to its placement in Rockland Harbor, Maine.

- ❖ **Refractometry Used to Analyze Blood Protein in Lobsters** –University of Maine researchers Dr. Gulni Ozbay and Dr. John Riley recently published the results of their studies on using refractometric methods in determining whole blood protein concentrations in lobster (“An analysis of refractometry as a method of determining blood total protein concentration in the American lobster *Homarus americanus*” *Aquaculture Research*, 2002, **33**, 557-562). They concluded that, “Refractometry as a method is reliable to determine blood total protein concentrations in the American lobster. Consequently, a refractometric method can be used directly by commercial distributors to assess responses to holding facility conditions and to feeding regimes.” They went on to say, “Whole blood protein concentrations may provide more information than serum protein concentrations.” For more information, please consult *Aquaculture Research* or contact the Lobster Institute.

- ❖ **2001-2002 Report on Lobster Pound Shrinkage** – The Lobster Institute has compiled the results for the Maine Lobster Pound Association's 2001-02 Pound Survey. With 14 pounds reporting, the average shrink was 11.9% -- with a range from .75% to 25%.
- ❖ **Bayer Named to Northeast Consortium Advisory Committee** – Dr. Robert Bayer, Executive Director of the Lobster Institute, was recently named to the Northeast Consortium Advisory Committee. Established in 1999, the Northeast Consortium encourages and funds partnerships among commercial fishermen, researchers, and other stakeholders for cooperative research and development of selective fishing gear technology. Their focus area is the Gulf of Maine and Georges Bank. Commercial fishermen are encouraged to participate in research activities and Consortium funding may be available to equip their fishing vessels for research purposes. The Consortium is an integrated effort between four institutions: Massachusetts Institute of Technology, University of Maine, University of New Hampshire, and Woods Hole Oceanographic Institute. For information about the Northeast Consortium check their Web site at www.northeastconsortium.org. ☼

Lobster Institute
210 Rogers Hall
The University of Maine
Orono, ME 04469



LOBSTER INSTITUTE

Lobster Bulletin, Fall 2002

Maine Fishermen's Forum Provides Scholarships

The Maine Fishermen's Forum Board of Directors offers scholarships to benefit immediate family members (son/daughter/grandchild) of anyone actively involved in Maine's seafood industry. Ten \$1,000 scholarships will be awarded by a random drawing at the 2003 Maine Fishermen's Forum (2/27-3/2). Undergraduates at a two or four year college who are in the second year of their program are eligible. Applications will be accepted through February 25 and can be obtained by calling 207-442-7700, or by downloading from the Forum Web site at www.maine seafood.org. *

2002 Roll Call of Donors to be Published in *Lobster Bulletin*

The Lobster Institute will publish its 2002 "Roll Call of Donors" in the Winter 2003 *Lobster Bulletin*. Those who contributed to the Institute during calendar year 2002 will be listed. If any contributor does not want their name published they may contact Cathy Billings at the Institute (207-581-2751) by January 15, 2002. *

Looking for Great Gift Ideas?

Support the Lobster Institute through our
Partner Providers Program

Visit our website at www.lobsterinstitute.org
and link to our Partner Providers :

- * Brandline Corp. - featuring Tervis Tumblers
- * Cutler's Custom Promotions - offering Lobster Institute merchandise
- * Lobster Direct - shipping lobsters worldwide
- * Yankee Magazine - great subscription rates

Attention Maine Lobstering Communities Looking for Waterfront Access

The Lobster Institute can work with you and your town's Board of Selectmen to explore opportunities to secure critical properties for coastal access for fishermen in your community. We can serve as a liaison to possible funding sources and organizations that can help you through the process. Contact the Lobster Institute at 581-2785.



**Please Remember
the Lobster Institute
in your Holiday Gift
Giving Plans !!**

This gift is from:

Name(s): _____

Address: _____

Phone: _____

Enclosed is my check for \$ _____ (payable to UMF-Lobster Institute)

Please charge my gift of \$ _____ to my VISA/MC

Acct. # _____ Exp. Date _____

Signature _____

✂ Clip & Mail to: Friends of the Lobster Institute
210 Rogers Hall, University of Maine
Orono, ME 04469-5763

From: Marti Gastineau, 1stBooks Library
Tel: 800-839-8640 ext.234 Fax: 812-339-6554

BOOK SIGNING:

Author Robert Delano Martin will be at the Annual Weekend for a book signing. He will have his book *The Tale of the Lobster* available for purchase and will autograph all copies. Stop by, pick up a copy (or 2) of his book and have him personally autograph it for you.

L is for Lobster

Astonish your friend with your know-how about the American lobster!

BEVERLY, MASSACHUSETTS—Robert Delano Martin presents a thorough review of lobster fisheries, for the casual and scholarly reader in *The Tale of the Lobster: A Practical Guide to the American Lobster, The Inshore and Offshore Lobster Fisheries, and the Hardy Souls That Pursue One of the Ocean's Finest Delicacies* (E-book version now available through 1stbooks Library, hardcover and paperback available soon).

The Tale of the Lobster delves into all aspects of the lifestyle of this remarkable crustacean, including a factual account of how, when, and where lobsters are caught by the brawny inshore and offshore “Lobstermen.”

Learn about the many conditions and restraints placed upon the American lobster industry. Reinforce your knowledge of the lobster by referencing the handy “Lobster Dictionary” provided for you by Martin. In addition, Martin includes a compilation of answers to the most commonly asked questions about the lobster.

Gain insight into the savvy satisfaction of knowing the proper way to buy, cook, and eat the lovable lobster. Come aboard a typical lobster boat for a pictorial review of a day of “lobstering” off the coast of Maine.

The author’s familiarity with his subject—the American lobster—is derived from close study of the animal through data research, by going out fishing with various lobstermen, and as an outcome of discussions with lobster marine scientists and other parties working with lobsters at the state and federal levels. It is through these interactions and much time spent in and around the coastal lobster fishery that the author is able to bring the reader up close and personal to his subject—the American lobster—*Homarus americanus*.

Robert Delano Martin is a long-time resident of Beverly, Massachusetts, and has a wonderful marriage of more than forty-eight years. He is the father of four grown children. He’s a graduate of Northeastern University, a veteran of the USAF and the Korean War.

ABOUT 1STBOOKS LIBRARY

The only profitable print-on-demand and eBook publishing company of its kind, 1stBooks Library was founded in 1997 and has helped more than 7,000 authors publish their works. For more information, visit www.1stbooks.com and click the “Media” image at the top of the page.

###

Room Registration Form - 2003

Please type or print clearly. Use a separate form for each room being reserved. Call the MLA for additional forms if necessary. Children under the age of 16 stay free in same room with their parents, however, meal tickets will have to be purchased separately for them.

Name: _____
1st Person 2nd Person

Mailing Address: _____
Street / PO Box City/Town State Zip

Daytime Telephone: (_____) _____ Fax: (_____) _____

Are you an Exhibitor? [] No [] Yes, Company Name _____

The Following Are Full Weekend Packages

2 Nights = Friday & Saturday 3 Nights = Thursday, Friday & Saturday

- [] Pkg #1 2 People / 2 Nights \$399.00
- [] Pkg #2 2 People / 3 Nights \$499.00
- [] Pkg #3 1 Person / 2 Nights \$279.00
- [] Pkg #4 1 Person / 3 Nights \$379.00

Full Weekend Packages include: Breakfast on Saturday and Sunday morning, Specialty Buffet on Friday night and Banquet on Saturday night including the Cocktail Party & Reception. Also includes all complimentary gifts.

The Following Are 1-Night Only Packages

(Includes dinner meal ticket for the night specified and breakfast the next morning plus complimentary gifts)

- [] Pkg #5 2 People / Friday Only \$225.00
- [] Pkg #7 1 Person / Friday Only \$150.00
- [] Pkg #6 2 People / Saturday Only \$225.00
- [] Pkg #8 1 Person / Saturday Only \$150.00

Rooms Only (No Meals Included)

Does **NOT** include complimentary gifts, which are reserved for those who purchase the above packages only

- [] Thursday Night Only \$110.00 (Single or Double)
- [] Friday Night Only \$110.00 (Single or Double)
- [] Saturday Night Only \$110.00 (Single or Double)

Additional Meal Tickets

- Specialty Buffet (Friday) # _____ @ \$35.00
- Banquet (Saturday) # _____ @ \$50.00

Ages 12 & Under Meal Tickets

- Specialty Buffet (Friday) # _____ @ \$20.00
- Banquet (Saturday) # _____ @ \$30.00

Special Requests:

- [] 1st Floor
- [] 2nd Floor
- [] 3rd Floor
- [] Oceanview
- [] Fireplace (no oceanview)

Day of Arrival:

Total Amount \$ _____

Please check how you would like to pay: [] MasterCard [] VISA [] Check (Payable to MLA)

Name: (as it appears on card) _____

Card # _____ Exp Date _____

Signature: _____

Mass. Lobstermen's Association
8 Otis Place, Scituate, Ma 02066-1323
Tel (781) 545-6984 Fax (781) 545-7837

Annual Weekend & Lobster Trade Show
Sea Crest Resort - No. Falmouth, MA

Exhibitor Booth Reservation - 2003

Company Name: _____

Company Address: _____
Street / PO Box City/Town State Zip

Daytime Telephone: (_____) _____ Fax (_____) _____

Contact Person in charge of booth: _____

Item(s) on Display: _____

# _____ BOOTH(S) @ \$385.00 Per Booth (Includes covered table & 2 chairs)	\$ _____
[] Need Electricity (\$30.00)	\$ _____
[] Need Lift for Engine (\$35.00)	\$ _____
[] Need # _____ Extra Table(s) (\$7.00 each)	\$ _____
[] Need # _____ Extra Chair(s) (\$3.00 each)	\$ _____

TOTAL AMOUNT: \$ _____

[] Same geographical location as last year / I wish to be located near _____

OTHER NEEDS and/or SPECIAL REQUESTS: _____

NOTE: Set-up time begins at 3:00 Pm on Thursday and must be removed by 3:00 PM on Sunday unless other arrangements have been made in advance. ALL EXHIBITS MUST REMAIN IN TACT AND NOT BE DISMANTLED PRIOR TO 11:00 AM ON SUNDAY MORNING.

Please check how you would like to pay: [] MasterCard [] VISA [] Check (Payable to MLA)

Name: (as it appears on card) _____

Card # _____ Exp Date _____

Signature: _____

GRAND AUCTION - 2003

WOULD YOU DONATE AN ITEM(S) TO BE AUCTIONED AT THE ANNUAL WEEKEND? **ALL PROFITS GO TO THE MLA SCHOLARSHIP FUND.** REMEMBER, AUCTION ITEMS DON'T ALWAYS HAVE TO BE MARINE RELATED. WE WELCOME ANY TYPE OF ITEM. THANK YOU VERY MUCH!

AUCTION ITEM #1:

DONOR'S NAME _____

COMPANY _____

DESCRIPTION OF ITEM: _____

VALUE \$ _____

AUCTION ITEM #2:

DONOR'S NAME _____

COMPANY _____

DESCRIPTION OF ITEM: _____

VALUE \$ _____

REMEMBER, AUCTION ITEMS DON'T ALWAYS HAVE TO BE MARINE RELATED. WE WELCOME ANY ITEM. THE FOLLOWING ARE EXAMPLES OF AUCTION TYPE ITEMS.

LIFE JACKET - LIFE RING
TOTES - WIRE - ROPE
CASE OF FRUIT
BUOY STICKS
SERVICES
LOBSTERMEN'S APRON

OUTER WEAR
ANCHOR LINE
OIL SAMPLING KITS
EVENT TICKETS
SURVIVAL SUIT
BILGE PUMP - HATCHES

BINOCULARS
FISHING SUPPLIES
ELECTRONICS
HOME MADE ITEMS
CANVAS TOTE BAG
TRAPS - BAIT

AFGHANS - PAINTINGS
LOBSTER GEAR
FURNITURE - LAMPS
GIFT BASKETS, VACATIONS
WALL HANGINGS
ETC. - ETC. - ETC.

CAPE COD TIMES

GOVERNMENT MAY EXPAND RIGHT WHALE PROTECTIONS

THE ASSOCIATED PRESS

BOSTON - An environmental group hoping to strengthen protections for rare right whales has asked the federal government to expand the whale breeding and living areas that are shielded by the Endangered Species Act.

The National Marine Fisheries Service last week said it would consider a petition by the Ocean Conservancy to expand so-called "critical habitats" in New England waters and off the southeastern coast, where North Atlantic right whales live.

The critical habitat designation recognizes an area as vital to an endangered species. It doesn't guarantee tighter restrictions for fishermen, shippers or others who share the waters with whales, though some fear that would result.

"They're going to bleed this for all it's worth," said Gary Ostrom, vice president of the Massachusetts Lobstermen's Association.

NMFS spokesman George Liles said if the petition is approved, the fisheries service will review existing rules, and could make changes.

The petition is open to public comment. NMFS must make a final decision by next July.

There are only 300 to 350 North Atlantic right whales remaining, and five died this year. Ship strikes and fishing gear entanglements are frequent causes of whale deaths. Restrictions to protect whales include closing fishing areas when the whales are nearby, reducing ship speeds and requiring the use of special fishing gear that breaks if a whale is caught.

Under the Ocean Conservancy petition, the water between existing

critical habitat areas in Cape Cod Bay and the Great South Channel would also be labeled a critical habitat, as would additional areas running about 10 miles north and 110 miles east of Provincetown.

Off Georgia and Florida, where the whales breed, the plan would add roughly 2,700 square nautical miles to the whale habitat.

Much of the new critical habitat areas already have restrictions to protect the whales under the Marine Mammal Protection Act.

But those restrictions can be abandoned relatively easily, while rules adopted under the Endangered Species Act are tougher because they must remain in place until the whales are out of danger, said Nina Young of the Ocean Conservancy.

Expanding the habitat designation also recognizes new science that shows the whales move in a much broader area than first thought, she said. "It's not a case of an evil environmental group coming down and looking for more regulations," Young said.

Young said the Ocean Conservancy would continue to work with the Atlantic Large Whale Take Reduction Team, a groups of scientists, fisherman and conservationists that recommends measures to prevent whale deaths.

(Published: November 22, 2002)

Copyright © Cape Cod Times. All rights reserved.

MILA Clothing + Novelties



Order Form

Also, look for more items on our website at www.lobstermen.com

MLA Clothing

MLA Baseball Jacket (Winter)	50.00
Denim with tan sleeves and trim. MLA logo on left chest. This jacket is heavy weight. Snap front	
MLA Grey Sweatshirt	20.00
Pullover sweatshirt with Hood and pouch. MLA logo on left chest, big red lobster on back	
MLA Grey Sweatpants	15.00
Gray (to match sweatshirt) Elasticized waist with drawstring. Mass. Lobstermen's Assoc down left leg.	
MLA Grey T-shirt (Sizes Small and 2X only)	12.00
Small MLA Logo on left chest, big red lobster on back	
MLA Denim Shirt	20.00
Long-sleeve blue denim shirt with Mass Lobstermen's Assoc embroidered & red lobster on left chest.	
MLA Boxer Shorts (<i>you gotta have a pair of these!</i>)	12.00
White boxers with red lobsters all over. Wear as boxers, or wear as shorts or PJ's. (No mediums left)	
MLA Beach Towel	20.00
Lobster Nation T-Shirt	ON SALE 5.00
White t-shirt with Lobster Nation picture on front (No large)	
Lobster Nation Sweatshirt	ON SALE 8.00
White sweatshirt with Lobster Nation Picture on front, MLA Logo embroidered on back	

For the Kids

Kids Colorful T-Shirts (<i>bright green, pink, red, yellow</i>)	10.00
Comical lobster on front (very popular, call for sizes)	
Kids White T-Shirts (Large only)	10.00
White Tee with abstract colors and lobsters on front	
Kids Sweatshirts (<i>just like the adults</i>)	20.00
Gray pullover with hood and pouch. MLA logo on left chest and large lobster on back	
Kids Sweatpants (<i>just like the adults</i>)	15.00
Gray with Mass Lobstermen's Assoc down left leg. Elastised waist with drawstring	

HATS AND BAGS

DENIM HAT - Blue denim with tan visor and MLA logo on front	10.00
Mesh Hat – Red mesh for the summer – MLA logo on front	5.00
Small Canvas Bag Purse size heavyweight canvas with leather fasteners and red lobster on front & zipper closure	18.00
Large Canvas Bag Supersize heavyweight canvas bag with pocket in front And MLA logo on front. Black leather handles. Very roomy!	25.00

NOVELTIES

Lobster Huggable Doll Great to wrap your arms around	15.00
Lobster Back-Pack Soft & plush, the kids will love toting things around in it	15.00
Lobster Slippers (<i>just adorable</i>) Red, of course, slip on slippers with lobster head and claws on front. Very cute – One size fits kids ages 3 – 8	8.00
Lobster Purses – Red lobster purse with shoulder strap	5.00
Lobster "Tails" – Large red tail with strap for fastening to waist When this is buckled on, the tail sits on top of backside. Very cute	5.00
Lobster Headbands – (<i>another cutie – kids love them</i>)	5.00
Lobster Swimmers – Plastic lobster with drawstring in front. Pull the string and tail slaps and claws move. This will actually swim in bathtub or pool.	3.00
COOKIE CUTTER – about 6" long – Comes with recipe and spice packet. Smells nice, can even be used as room freshener	5.00
Tablecloth Set – Wipe clean plastic rectangular tablecloth, quilted oven mitt and small tea towel. All pieces are white with red lobsters and gray clams	12.00
Placemats (set of 4) – Plastic and same design as tablecloth set	9.00

WE'RE CLEANING INVENTORY LOOK WHAT \$1.00 WILL BUY

- Yellow Rain Ponchos** - One size fits all. **SOLD OUT** Logo on front 1.00
- MLA Blue Tote Bags** – Blue cloth with MLA logo on front. 1.00
These are slightly larger than 11 x 12 so they are great for
Carrying books, papers, work, or small toys for travel
- Flashlights** - Yellow flashlight that can be used as a regular 1.00
flashlight or you can pop up handle and use as lantern.
Even comes with its own batteries!
- Keychains** – Metal nautical design with MLA logo 1.00
- Jar Openers** – Everyone needs a couple of these. They're great 1.00
for opening up jars and caps. Get a couple!

Please use the order form on the back.

Remember.....all profits benefit the MLA Scholarship Fund!

Mail Order form with check or money order payable to:

**MLA
8 Otis Place
Scituate MA 02066-1323**

OR

Place order by phone at 781-545-6984

OR

Fax order to 781-545-7837

(Phone orders and Fax orders must be paid by credit card)



MLA ORDER FORM

ITEM	QUANTITY	SIZE	PRICE EACH	TOTAL COST
BASEBALL JACKET (HEAVYWEIGHT)			50.00	
ADULT GRAY SWEATSHIRT			20.00	
ADULT GRAY SWEATPANTS			15.00	
ADULT GRAY T-SHIRT			12.00	
EMBROIDERED DENIM SHIRT			20.00	
BOXER SHORTS			12.00	
BEACH TOWEL			20.00	
ADULT LOBSTER NATION T-SHIRT			5.00	
ADULT LOBSTER NATION SWEATSHIRT			8.00	SOLD OUT
KIDS COLORFUL T-SHIRTS			10.00	SOLD OUT
KIDS WHITE T-SHIRTS			10.00	
KIDS GRAY SWEATSHIRT			20.00	
KIDS GRAY SWEATPANTS			15.00	
DENIM HAT			10.00	
MESH HAT			5.00	SOLD OUT
SMALL CANVAS BAG			18.00	SOLD OUT
LARGE CANVAS BAG			25.00	
LOBSTER HUGGABLE DOLL			15.00	SOLD OUT
LOBSTER BACK PACK			15.00	
LOBSTER SLIPPERS			8.00	
LOBSTER PURSE			5.00	
LOBSTER "TAIL"			5.00	
LOBSTER HEADBAND			5.00	
LOBSTER SWIMMERS (TOY)			3.00	
COOKIE CUTTER, RECIPE & SPICE PKT			5.00	
TABLECLOTH SET			12.00	
PLACEMATS (SET OF 4)			9.00	
YELLOW RAIN PONCHOS			1.00	SOLD OUT
MLA BLUE TOTE BAGS			1.00	SOLD OUT
FLASHLIGHT (LANTERN)			1.00	
KEYCHAIN			1.00	
JAR OPENERS (GRIPPERS)			1.00	

Shipping & Handling	\$3.00 plus .75 each item thereafter	\$
--------------------------------	---------------------------------------------	-----------

TOTAL	\$
--------------	-----------

VISA MasterCard

Card#: _____ Exp: _____

Signature: _____

Ship to:		
Print Name: _____		
Street Address: _____		
City: _____	State _____	Zip _____

WE DELIVER FRESH LOBSTER BAIT

INCLUDING:

HERRING

POGIES

MACKEREL

RED FISH

SKINS

FLAT FISH

WHITE FISH

SALMON

**SALT
&
ICE**



**LARGEST INVENTORY
OF FRESH, SALTED, AND QUICK FROZEN BAIT**

CHANNEL FISH CO.

EASILY ACCESSIBLE FROM THE NORTH AND SOUTH OF BOSTON

CALL (617) 569-3200

*370 EAST EAGLE STREET
EAST BOSTON, MA 02128*

UP AND DOWN THE
NEW ENGLAND COAST WE
ARE THE ONES THAT **WILL**
DELIVER YOU THE MOST

OPEN 24 HOURS A DAY MONDAY A.M. TO SATURDAY P.M.

NEW ENGLAND'S **LARGEST** SUPPLIER OF
LONGLINE GEAR

5000 HOOKS \$2795.00

COMPLETELY RIGGED

MAIN LINE --- GANGINGS --- EZ BAITER HOOKS

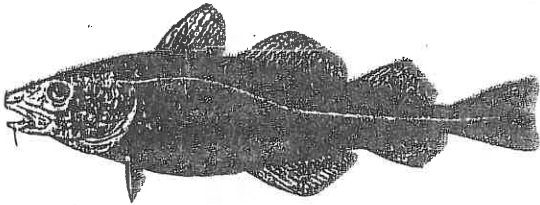

VOLUME DISCOUNTS ON
MUSTAD AND VMC HOOKS

OVER 100,000
IN STOCK

OVER 30 styles & sizes

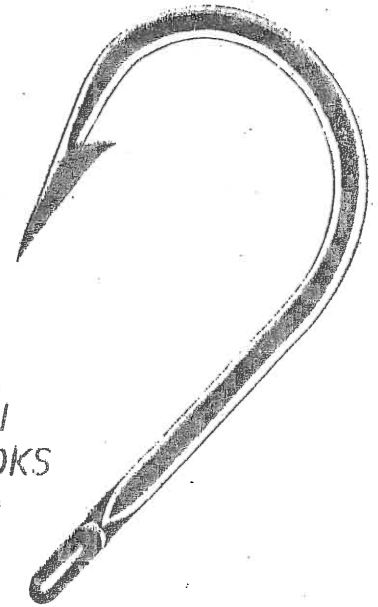

AND OF COURSE... **LOBSTER GEAR**

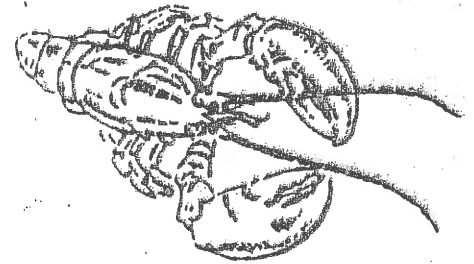

NEW GAUGES ----- ROPE CUTTING BOXES ----- ROPE METERS

CARLON BUOYS

ALWAYS IN STOCK...
ALWAYS PRICED RIGHT!

NEW VENTS
\$39.00/100

WELLINGTON-PURITAN

SINKING & FLOATING
CALL FOR A PRICE!!!

RIVERDALE WIRE -- FLEXABAR PAINT -- BRANDERS

WE'RE WORTH A RIDE TO THE CAPE.....

MON -- FRI 8 am - 5 pm SAT 8am - 12noon MASTERCARD * VISA * DISCOVER



P.O. BOX 172 / 67 DEPOT STREET / CHATHAM, MA / 02633 / 508 945-3501 / FAX 508 945-3373



New England

MARINE & INDUSTRIAL



Practical Pullovers for Winter Gift Giving



**Guy Cotten
& Grundens
Winter Pullovers**



Your Choice

\$84.30

Fleece Lined,
Hooded with
Zipper Closing &
Drawstring,
Storm Cuffs &
Two Side Pockets



Stocking Stuffers & Other Gear To Keep Away The Winter Chills.

Hard Core Hand Cream

Chappy's Lip Balm

Goatropers

Baffins

Watchcaps

Gloves

Socks



Stop in at our 4 locations.



New England

MARINE & INDUSTRIAL

Now Carrying!

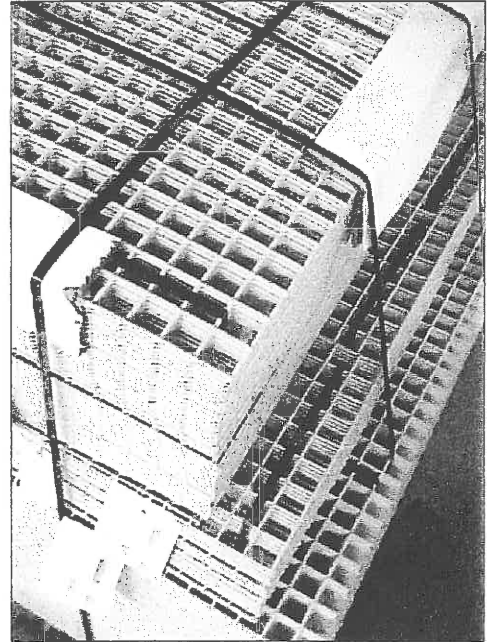
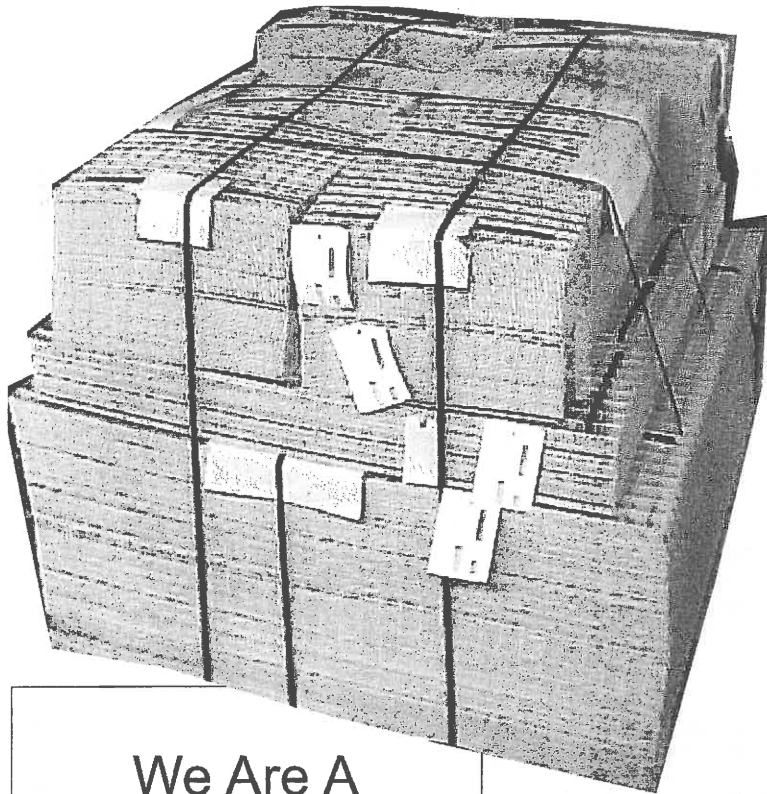

Riverdale Wire

We Are A
Stocking Dealer
For Riverdale
Lobster Trap
Repair Wire and
Trap Kits.

Call for
Information.

At All 4 Locations

Portsmouth

200 Spaulding Tnpk. Portsmouth, NH 03801
603-436-2836
800-492-0779
fax 603-433-2239

Gloucester

3-5 Parker St. Gloucester, MA 01930
978-281-2080
866-281-2080
fax 978-281-8862

Brant Rock

294 Ocean St., Brant Rock, MA 02020
781-834-9301
888-834-9301 in MA
fax 781-834-8653

Stonington

Cemetery Rd. Stonington, ME 04681
207-367-2692
800-660-2692
fax 207-367-5951

ROSE'S MARINE CO.

NEW 15" HAULER ASSEMBLY

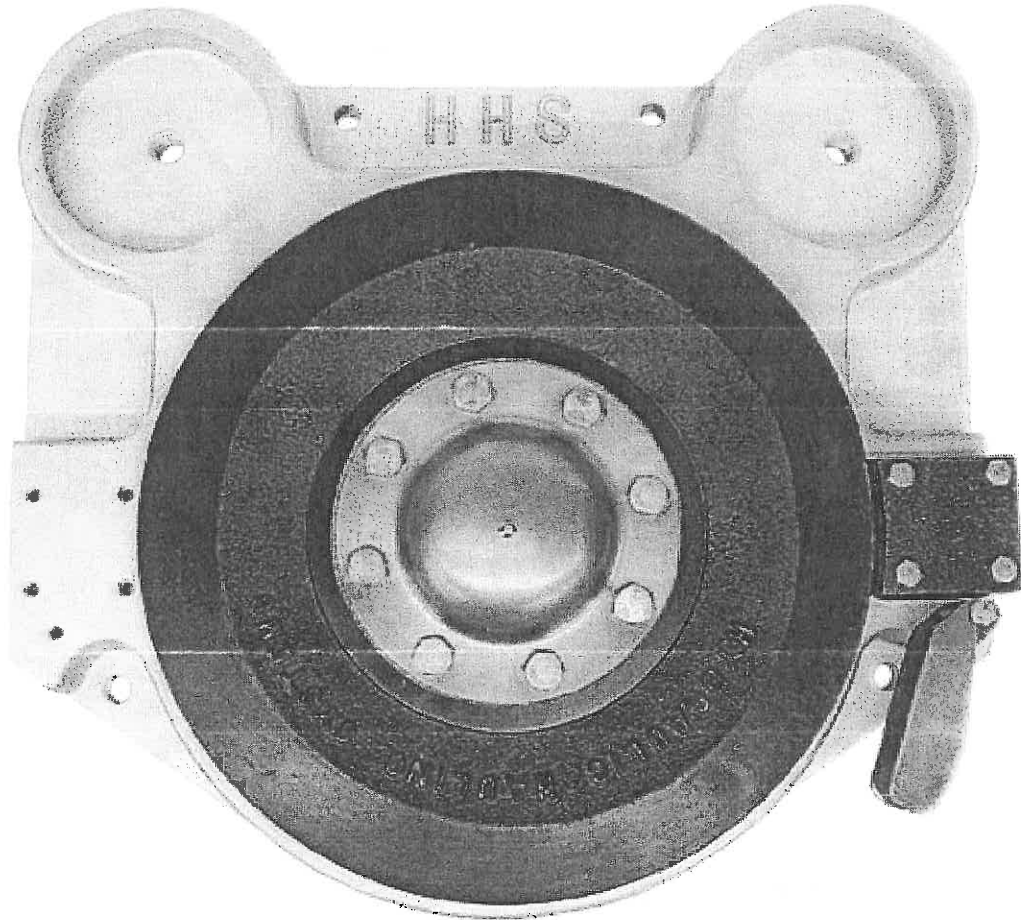

2,970 LBS LINE PULL • 84 FPM LINE SPEED
3/4" HAULER PLATES • 1/2" STAINLESS STEEL HUB BOLTS

STARTING AT \$1,453.⁰⁰

CALL FOR DETAILS



ROSE'S MARINE CO.

375 MAIN ST. GLOUCESTER, MA 01930

TOLL FREE: 877-283-3334

DIRECT: 978-283-0280 FAX: 978-283-3308

e-mail: parts@rosesoil.net website: www.rosesmarine.com

TITAN

MODEL TH 1 PLANETARY WINCH

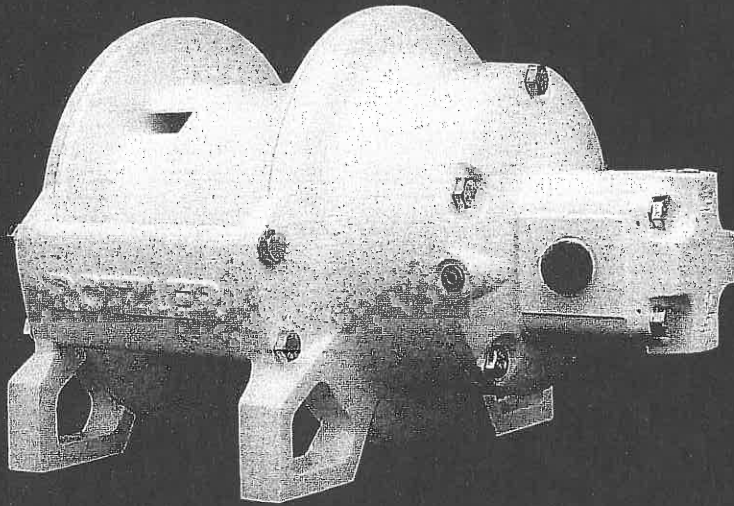

1 METRIC TON HOIST CAPACITY

MAXIMUM LINE PULL

Bare Drum: 2200 LB

SYSTEM VOLUME

Maximum: 10.2 USGPM

MAXIMUM LINE SPEED

Bare Drum: 126 FT/MIN

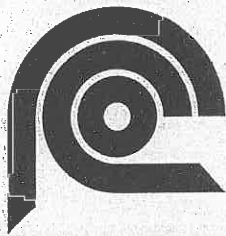

ROTZLER®

TOMORROW'S TECHNOLOGY FOR THE WORLD TODAY

AVAILABLE AT

ROSE'S MARINE CO.

375 MAIN ST. GLOUCESTER, MA 01930

TOLL FREE: 877-283-3334

DIRECT: 978-283-0280 FAX: 978-283-3308

e-mail: parts@rosesoil.net website: www.rosesmarine.com



WHOLESALE PRICE LIST

FALL 2002

LOBSTER FISHING GEAR

SPONGEX BUOYS: (Case lots only)		
5 x 11 x ¾"	48 to case	\$2.10 ea.
7 x 7 x ¾"	40 to case	\$2.10 ea.
6 x 14 x 1"	30 to case	\$3.75 ea.
7 x 14 x 1"	20 to case	\$5.00 ea.
7 x 15 x 1"	15 to case	\$5.50 ea.

BUOYS: (Case lots only)	
8 x 16	\$6.50 ea.
9 x 16	\$9.25 ea.

SECOND BUOYS: (When available)		
5' x 11 x ¾"	48 to case	\$1.65 ea.
7 x 7 x ¾"	45 to case	\$1.65 ea.
6 x 14 x 1"	30 to case	\$2.75 ea.
7 x 14 x 1"	20 to case	\$3.75 ea.
7 x 15 x 1"	15 to case	\$3.95 ea.
9 x 16 x 1 ¼"	12 to case	\$6.50 ea.

LOBSTER GAUGE \$9.95 EA.

**WORM RESISTANT
Buoy Sticks**
 3, 4 & 5 feet 7/8" thick
 Packed 25 to bundle
 30¢ per foot

SLIDERS Oak 3-feet
 Mill run stock/ packed 20/ 25¢ per ft

LOBSTER BANDS WINMORE IMPORTED 1ST QUALITY

Regular Bands	25 lb. box	\$1.35 lb.
Regular Shedder Bands	25 lb. box	\$1.35 lb.
North Atlantic Bands	20 lb. box	\$1.50 lb.
Cold Water Bands	20 lb. box	\$1.50 lb.

WRAP-AROUND	3x6 ½ MESH	\$6.00 LB.
WRAP-AROUND	Black, Tarred	\$6.75 lb.
ESCAPE VENTS	Black Plastic	50¢ ea.
HEADS	Machine Made Mesh	\$4.75 set
TWINE	750 or 1050	\$5.00 lb.

HOG RINGS		
Stainless Steel 3/8", ½", or ¾"		\$5.00 lb.
¾" Iron Degradable		\$2.00 lb.
Hog Ring Pliers		\$7.50 ea.

SHOCK CORD
 ¼" 500 foot roll \$30.00 each roll

BAIT BAGS:	Heavy Duty Plastic	13" Wd x 18" lg	\$25.00 per 100
	Extra Heavy Duty	15" Wd x 18" lg	\$27.50 per 100

Bait Bags, Hand Knitted, Double Draw
 String 14" long, orange \$9.50 dozen

BAIT BAG MATERIAL	Heavy Duty Plastic	13" wide / 1600 foot rolls	.10¢ per foot
	Extra Heavy Duty Plastic	15" wide / 1600 foot rolls	.12¢ per foot

ROPE	Poly Pro Line Floating	\$1.35 lb.
	5/16" or 3/8" Sinking	\$2.10 lb.

EEL TRAPS 12" X 24" Vinyl Coated Wire
 ½" x ½" Mesh \$27.50 ea.

LIVE CARS	30 x 18 x 12" Plain	\$21.00 ea.
	36 x 18 x 12" Plain	\$23.50 ea.

LOBSTER TRAPS:

Vinyl Coated Wire, 1 ½ x 1 ½ mesh
 2 Bricks, full size tie-down shock cord
 30 x 18 x 12" \$30.00 ea. (10 or more)
 36 x 18 x 12" \$32.00 ea. (10 or more)
 36 x 21 x 13 ½" \$35.00 ea. (10 or more)
 W/Runners \$2.50 more ea.

Bi-Weekly deliveries to the South Shore

Henry J. Ferri D/B/A SEA PRODUCTS CO.
 PO Box 817 No Falmouth MA 02556-0817
 (508) 563-6217

All above items in stock unless otherwise indicated. All previous prices are hereby cancelled. **TERMS**
 C.O.D. F.O.B. No Falmouth, MA. Prices subject to change without notice. **NET 10 days to established**
 accounts. Deliveries available. Parcel Post or UPS on request. **WAREHOUSE PICK-UPS by appointment**
ONLY.

HYDRO-SLAVE

SAME DAY SERVICE AND TECHNICAL SUPPORT

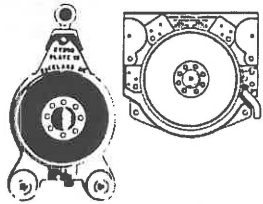

WARNER ELECTRIC CLUTCHES

- Autopilot Hydraulic components
- Hydraulic powered WATER PUMPS
- Power Steering systems
- Hydraulic Trap LIFTERS
- Electric models start at \$790 retail

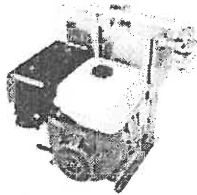

5.5 HP HONDA POWER UNIT

- 11GPM @ 1500 PSI 2 Stage Pump
- Light, Versatile and Portable
- HYDRAULIC WATER PUMP WITH NEW TROUBLE FREE HYDRAULIC MOTOR

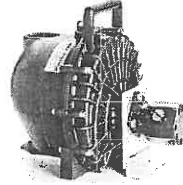

OUR NEW GENERATION SUPER BLOCKS SUPER LOBSTER BLOCKS



- 4" Low LIP and HI LIP
- 5" Low LIP and HI LIP
- 2000 lb. Capacity
- Sealed tapered roller bearings
- Aluminum sheaves
- Stainless Sheaves coming soon

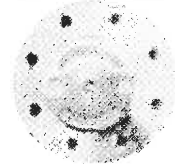

12" SS HUB \$99.00



TITAN
PLANETARY WINCH

1 METRIC TON optional high pressure hydraulic motors—integral external brake release stainless steel drum seal surfaces—polyester powder coating

2 METRIC TON rubber coated seals—graphite resin brake plates—no case drain required, plated or stainless steel fastener options—2 year warranty

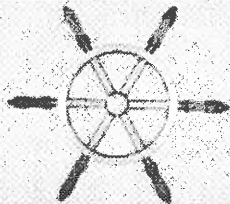

STEERING WHEEL

\$160.00

Our newly designed 16" bronze spoked steering wheel features teak handles and a machined surface. It is also available in a chrome plated version for yachts or any boat that prefers an extra nice finish.

WORLD'S LARGEST POT HAULER MFG. FOR 36 YEARS

Call John for more information 1-800-747-7550 • Or visit us on the internet: <http://www.midcoast.com/~marinhyd/>

MARINE HYDRAULIC ENGINEERING

17 Gordon Drive • Rockland, Maine • Fax: 207-594-9721 • Email: marinhyd@midcoast.com

***When it comes to service and support, you know
you can count on the Rhino!***

— DEALERS —

• We provide the best products and the best product support in the business, backed by a well-stocked warehouse from which we ship daily. **NO ORDER TOO BIG — NO ORDER TOO SMALL!**

— FISHERMEN —

• Our RHINO TUFF WIRE is tough — It's the biggest trap wire available, and has more than enough zinc (which means no premature rusting). Plus our PVC Coating is the best in the business!

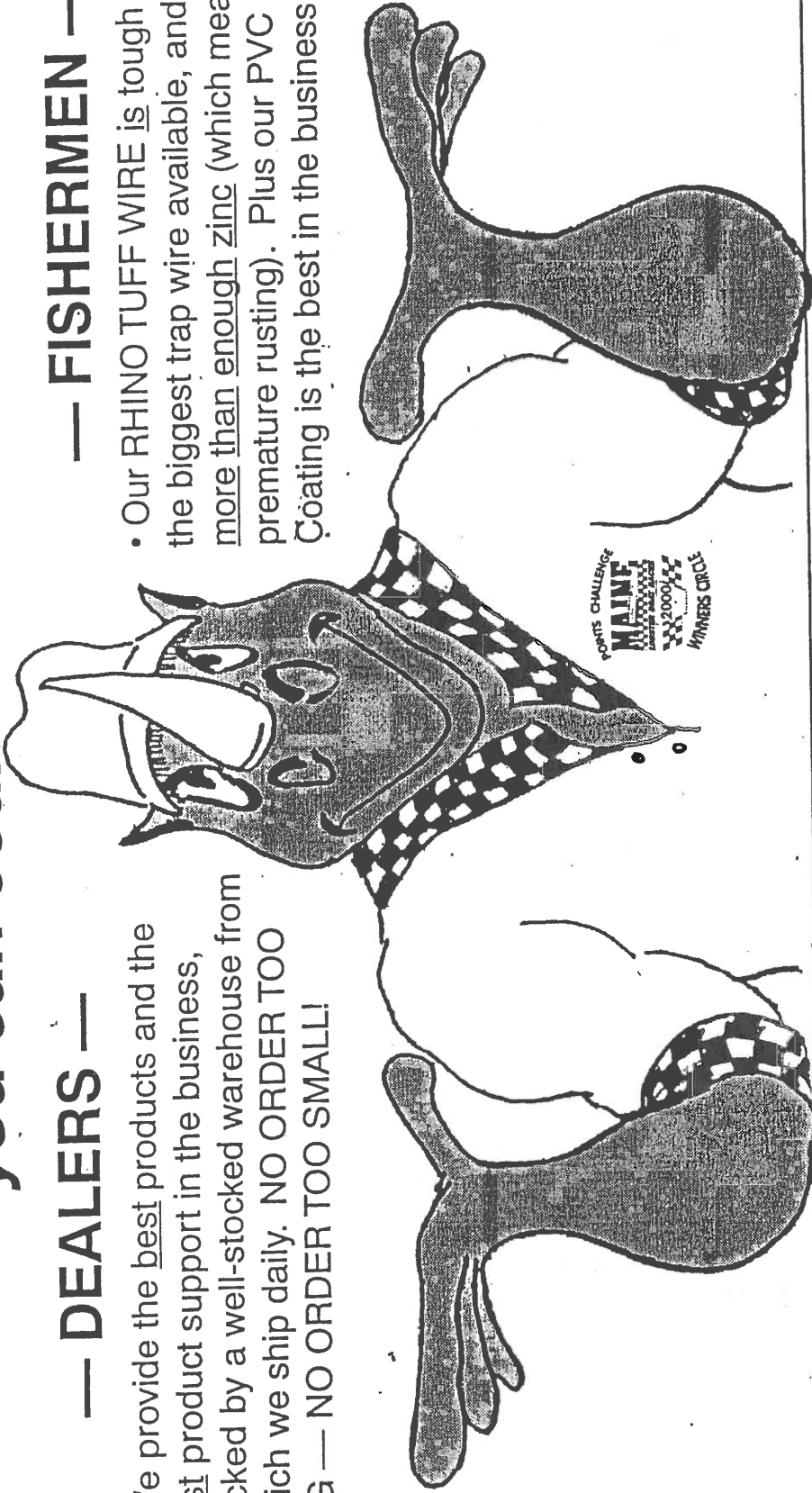

SHEPHERD LOBSTER WIRE

IN NEW ENGLAND FOR OVER 20 YEARS

PO Box 314 • Mills Road • Newcastle, ME 04553

Tel: (207) 563-3595 Fax: (207) 563-3597

Sponsor: Annual Maine Lobster Boat Race Points Challenges



**Your Best Source for
All Your Supply Needs. . .**

RNR

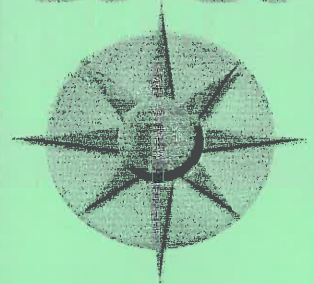

**MARINE
SUPPLY**



**Tote
Hook**

USA Made
30" \$24
36" \$26

**North
Atlantic
Bands
by Winne
20 LB. Box
\$ 29**

**Herk 16
\$59**

**Lobster
Line
1200'**
11/32 \$ 69
3/8 \$ 80
7/16 \$ 110

New!



**Brig 40
Jacket
\$59**

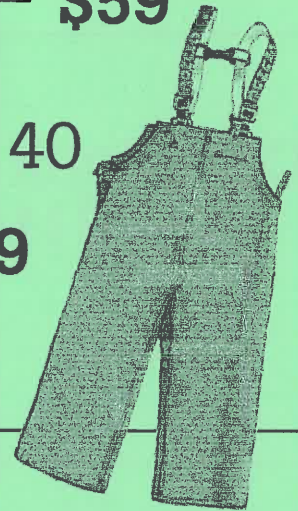

**Warren
Replacement
Sheeves**

*You know..
the "Green Ones" and
"PinSavers"*

**3 Strand Fid
small \$6 large \$9**

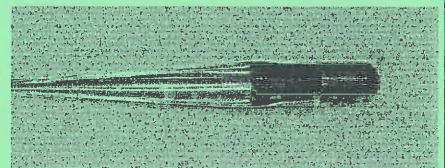

plus MORE.....

Call for Delivery

781-585-1910

**Call Now . . . We Deliver
from Boston to Plymouth**

RNR

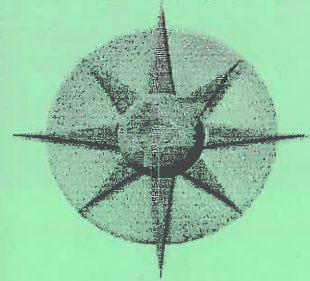

**MARINE
SUPPLY**



**Breakaway
Line**

Whale Safe
650/680 lb
\$ 50

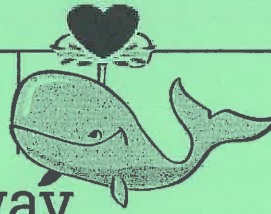

Flags
8 x 11
**\$ 1
each**

CorrosionX
16 oz **\$11**

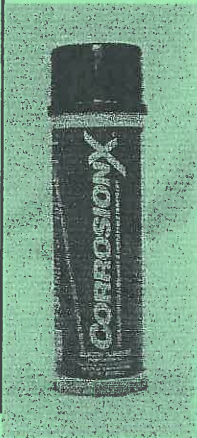

**S.S.
V-Notch
Tool \$10**



WWD 110



**Astron
Boots**
with liner
\$49

Knives

*Victronoix
Red \$30/case*



plus much, much MORE.....

Call for Delivery

781-585-1910

CONGRATULATIONS!

to

Eric deDoes

President, Plante's Lobster Escape Vents

on his award of U.S. Patent
No. 6,457,896 to the

PLANTE BREAKAWAY SWIVEL

Making, using or selling swivels of the type claimed
in the patent is a violation of U.S. patent law.

See your local dealer for
PLANTE'S fine products.

For more information on Mr. deDoes patented swivel contact:
plantes@gwi.net
207-549-7204

Use the same technology the US Navy uses on its propellers...

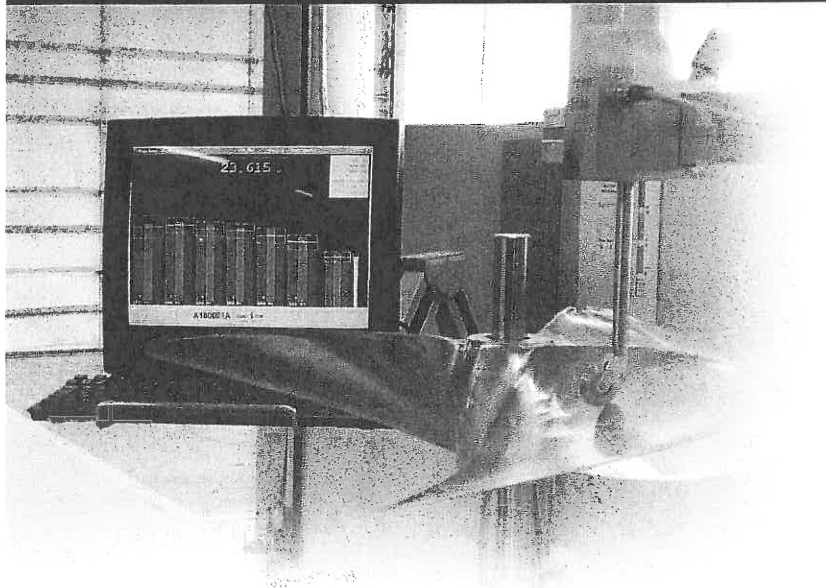

- ✓ Saves Fuel
- ✓ Increases Speed
- ✓ Reduces Vibration

- ✓ Pitch Accuracies to 0.001 of an inch
- ✓ Competitive Pricing
- ✓ Quick Turn Around

Benchmark Propellers uses the revolutionary marine propeller inspection system, **Prop Scan**, enabling your propeller to be remanufactured, repaired or modified to levels of accuracy within *.001 of an inch*—an accuracy unparalleled—and it's provided at a *competitive price*.

Increase the performance of your boat!...Having your propeller calibrated at Benchmark is a minor investment that will help increase the life of your boat. Prop Scan *reduces propeller vibration* that can damage your engine, *increases the speed* of your boat, and *reduces fuel consumption*, so you can ride smoother, faster for less.

With our "state of the art" technology we make your propellers literally better than new!...Call Benchmark today at 508.732.0073!

➤ SPECIAL INTRODUCTORY OFFER! ◀

FREE

DETAILED COMPUTER ANALYSIS
of your propeller

10% OFF

your first PROPELLER REPAIR

BRING THIS AD INTO BENCHMARK PROPELLERS TO REDEEM. OFFERS AVAILABLE ONLY FOR SERVICES RENDERED AT BENCHMARK PROPELLERS. EXPIRES OCTOBER 15, 2002.



PROPELLERS

B E N C H M A R K

Performance through Accuracy

www.benchmarkpropellers.com
Building 36, Cordage Park
Plymouth, MA 02360

508-732-0073

BUZZ BAIT

"Call for the "buzz" on our bait!"

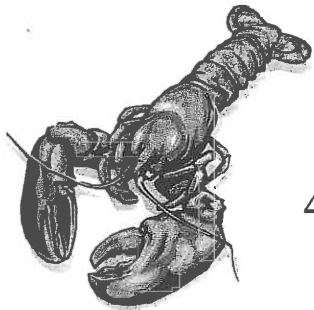

Buzzards Bay Trading Co., Inc.

49 Hassey Street, New Bedford, MA 02740

Tel(508)996-0242 Fax(508)996-2421

Quality Fresh, Frozen, and Salted Baits
Convenient Location for pick up
Dockside Delivery Available



- Herring in stock now!
- Mackeral in stock now!
- Skate in stock now!
- Flatfish Racks in stock now!
- Cod/Haddock Racks in stock now!
- Fish Heads in stock now!
- Fish Skins in stock now!
- Pogies Call for availability!
- Clam Bellies in stock now!
- Whole Clams in gallons in stock now!



Call Steve the "Master-Baiter"



Coastal Hydraulics, Inc.

Electric Clutches & Mounts

Shaft or V-Belt Driven - NO Maintenance

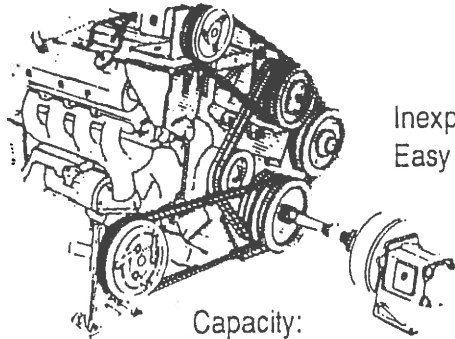

Inexpensive
Easy to Install.

Capacity:
Up to 85 gallons per minute
from 75 up to 1,000 foot pounds

Balanced Hydraulic Components Available

Distributor
PITTS
The Clutch People.

Distributor
 components
GRESEN pumps & valves

Char-Lynn

Thousands in marine use. Proven trouble free. 1 year guarantee.

The Pressure Is On Board.

Clean traps catch more.
Our pressure washers are proven.

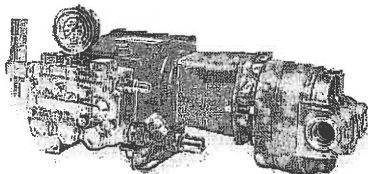

Hydraulic

4.5 gpm
@ 3000 psi

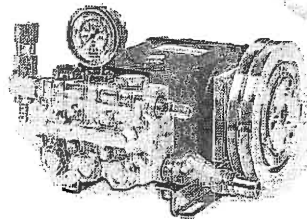

Belt-driven with
Electric Clutch



Coastal Hydraulics, Inc.

28 ROUTE 286 • PO BOX 2832 • SEABROOK, NH • 03874-2832

Call 603-474-1914

TELEPHONE (603) 474-1914

FAX (603) 474-1902

Life Rafts
&
Survival
Gear

Scallop,
Groundfish,
Quahog,
Lobster
Gear



MARINE DIVISION

44 South Street, New Bedford, MA 02740

508-993-0010 1-800-467-8865

Fax: 508-993-9005

john4impnb@aol.com

COMMERCIAL FISHING - MARINE SAFETY

Marine Hardware • 66°N • Buoys • Wire Rope •
Lobster Bands • Fish Tubs • Cordage • Netting •
Floats • Leadline • Helly Hansen

Electronics for all boats • Golf and Batting cage netting
USCG Service Station #327 Safety Inspection
Polyform U.S. Buoys & Fenders – All Colors

NYLON FLEA BAGS IN ALL SIZES – SAVES YOUR BAIT!

SPECIAL

15' HI FLYERS

10' LOW FLYERS

PLENTY IN STOCK ~ ORDER NOW!

Recreational
BOATING
Equipment

1 Stop
Gillnet Shop
We Strip,
Hang & Ship



1005 CORPORATE PARK
PEMBROKE, MA 02359

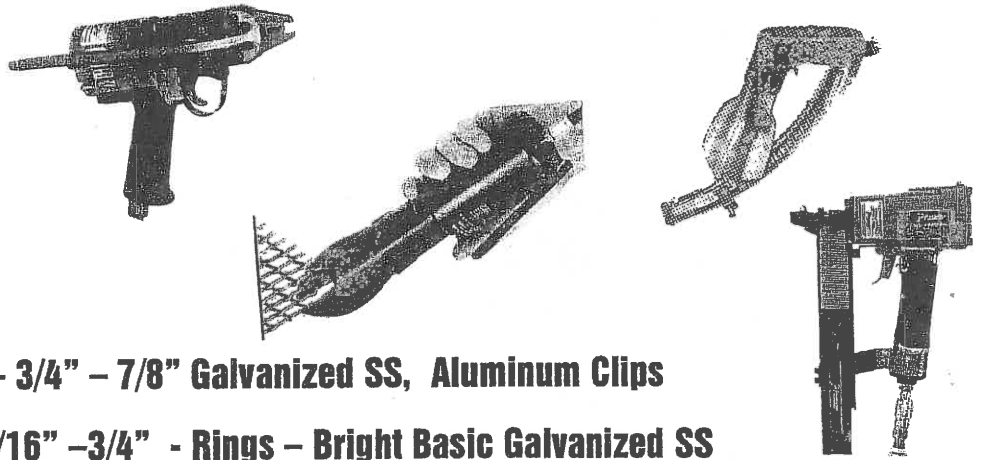

- "Hartco" Clip Guns – 3/8" – 3/4" – 7/8" Galvanized SS, Aluminum Clips
- Ring Guns – 3/8" – 1/2" – 9/16" – 3/4" - Rings – Bright Basic Galvanized SS
- Staple Guns – 1/4" – 3/8" – 1/2" Crown Staples Galvanized SS – 18 – 16 – 14 Gauge
- Wire Cutters – Flush Cutting Jaws For 14 – 10 – 8 Gauge Wire
- Shepherd Lobster Wire

We've Moved!

Minutes from our old Hanover location
to 1005 Corporate Park, Pembroke, MA.
Our phone & fax remain the same

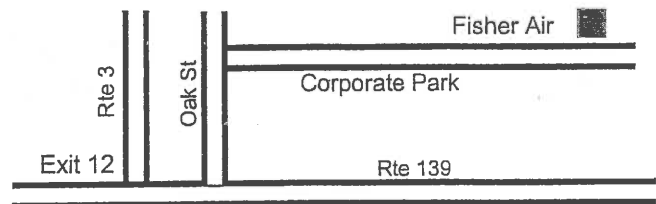

Tel (781) 826-2522

Fax (781) 826-5252



VISIT OUR WEB SITE
<http://www.sinko-inc.com>

Sinko U.S.A. INC.

THE ORIGINAL & PROVEN LOBSTER / FISH TRAP BALLAST RUNNERS

- * ELIMINATES CONVENTIONAL BALLAST & RUNNERS
- * WELL-BALANCED TRAP
- * ALWAYS LANDS UPRIGHT
- * EASY TO INSTALL (CLIP ON)
- * REMOVABLE, NOT PART OF TRAP
- * REPAIR EXISTING TRAPS
- * STRENGTHENS TRAPS
- * MARINE WORM PROOF
- * COST EFFICIENT

*OFFSHORE
INSHORE
holds in strong
tides. Great in
deep water.*

Frank Thompson
FV Independence
Vinnal Haven, Me

OVER 9 SEASONS
IN THE WATER

U.S.A. PATENT # DES.365,135

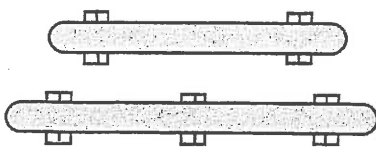

TESTED OVER 8,000 LBS. PSI.

CALL TOLL FREE



EZ BRICK

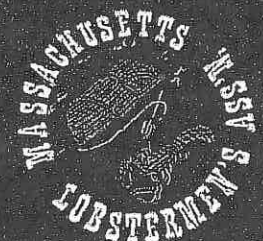

ATTENTION TRAP BUILDERS

Our Distributors are:
Brooks Trap Mill; Thomaston, ME
Phone # 207-354-8763
Ketcham Trap; New Bedford, MA
Phone # 508-997-4787

EZ BRICK REPLACES A
CONVENTIONAL BRICK
STAYS IN PLACE, AND
AS STRONG AS A
Sinko PRODUCT
APPROX. 5.5 LBS
SIZE 5 X 10 X 2 INCHES

1-888-Sinko79

2001

FERTIG-MARCH

Since 1928



TRIDON GEAR DRIVE HOSE CLAMPS

No. B-16

(11/16" to 1-1/2" range)

1.95 per Box
17.45 per 10 Boxes (100 Clamps)

800-621-4276

FAX 800-767-6118

10 Clamps per Box
Other Sizes Available

We Accept...



**FREIGHT ALLOWED ON
ORDERS OF \$150.00 OR MORE.**

FERTIG-MARCH

P.O. BOX 11

SHELBYVILLE, IN 46176-0011

ROS Boats, Inc.

785 American Legion Hwy (Route 177) Westport, MA

• **CUSTOM BUILT BOATS**
WORK OR PLEASURE AT
WHOLESALE PRICES.

• **CUSTOM BUILT TO ORDER**
• **KITS AVAILABLE -**
CALL FOR QUOTES
USED BOATS AVAILABLE

New ROS 27' or 30'
on Winter Specials.
Cuddy cabins, Lobster boats, Tuna
boats, Bass boats, Center cabins,
& Center consoles

**WINTER
SPECIALS**

**FACTORY
DIRECT**

ALL HAND LAID

**ORDER EARLY
& SAVE!**

**PROFESSIONALLY
CUSTOM BUILT**

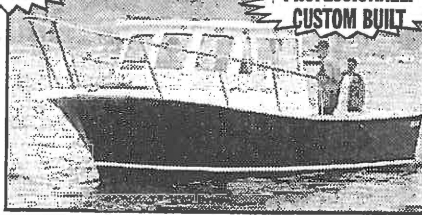

• **INBOARD OR OUTDRIVE • HARD CHINE • FAST HULL DESIGN**
• **STABLE • EXCELLENT SEA BOAT • HEAVY DUTY SOLID GLASS CONSTRUCTION**
BUILT YOUR OWN FROM OUR KITS OR WE'LL CUSTOM BUILD FOR YOU!

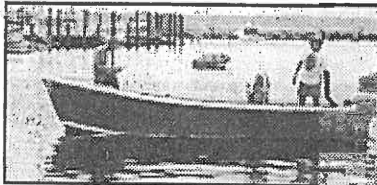

ROS Open Skiff Special.
13' to 24', many custom options available.



New ROS 24' Lobster Boat Special.
Also available-8', 10', 13', 17', 19' and 21'.
Call for prices.

Dealer Inquiries Wanted For 8', 10', & 13'

BOAT HAULING SEASON
SPECIAL W/STORAGE

(508) 636-2295

- FIBERGLASS OR WOOD REPAIRS
- GELCOAT FIBERGLASS COMPONENTS
- CAULKING - PLANKING
- FIBERGLASS SUPPLY

INTRODUCING:

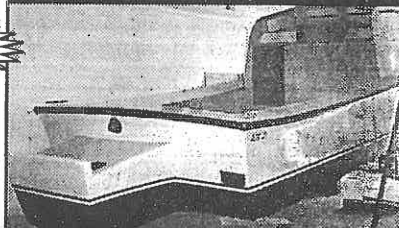

ROS CUSTOM OUTBOARD MOTOR SEA DRIVE BRACKET:

- EXTENSION OF EXISTING HULL
- HAVE YOUR TRANSOM REPAIRED
- PROVIDES BETTER ALL AROUND PERFORMANCE THAN CONVENTIONAL BRACKETS
- ADDS BUOYANCY TO YOUR BOAT
- REDUCES CAVITATION
- CUSTOM DESIGNED FOR YOUR BOAT
- HELPS HOLD UP ENGINE FOR BALANCE
- HELPS YOUR FULL TRANSOM FOR SEAWORTHINESS
- WE CAN CONVERT YOUR STERN DRIVE INTO AN OUTBOARD BRACKET, BETTER & FOR LESS
- CALL FOR PRICES

THERE'S A REASON MORE PEOPLE HAVE TRUSTED US FOR OVER 20 YEARS.

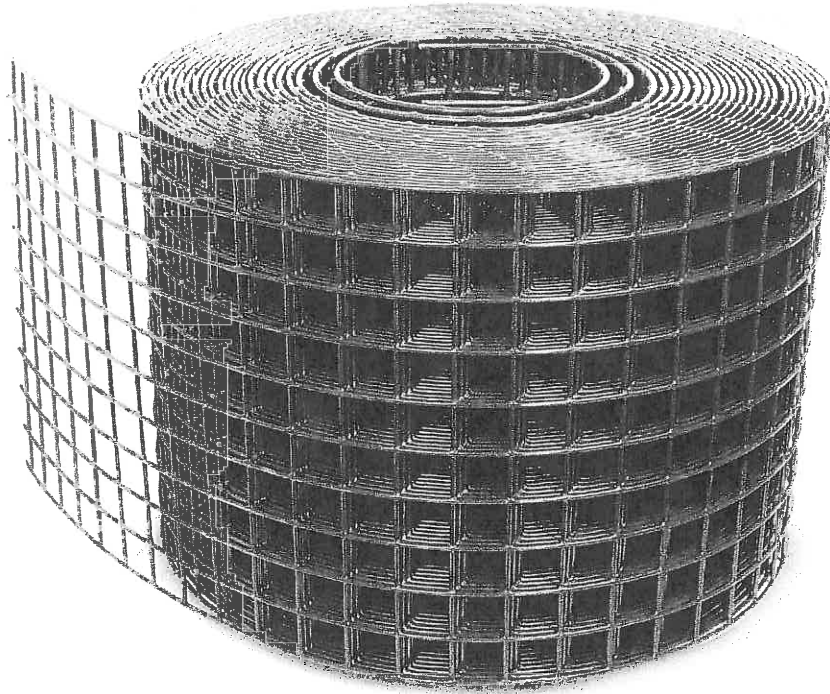

WHEN IT'S AQUAMESH® ON THE OUTSIDE, THERE'S MORE ON THE INSIDE.

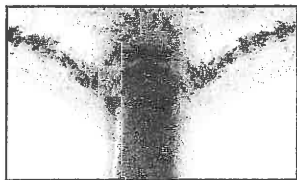

*Aquamesh® GAW process
ensures long life in the
harshest conditions.*

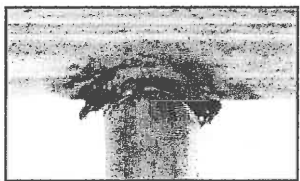

*Welding heat burns zinc exposing
the wire to the elements.*

Only Aquamesh® wire from Riverdale Mills is made from a proprietary welding and coating process that helps traps last longer and perform better. Unlike ordinary wire mesh, our unique Galvanized After Welding (GAW) technique completely surrounds the wire weld with zinc to prevent deadly rust. With Aquamesh you get long-lasting durability that's unmatched by any other in the industry. So if you're looking for trap wire that can stand the test of time, look to the one name lobstermen have trusted for over 20 years -- Aquamesh.



RIVERDALE

Northbridge, MA 01534 • 800-762-6374 • www.riverdale.com

AQUAMESH® OCEAN TOUGH.

NOW TWO LOCATIONS: BOSTON AND PLYMOUTH
**NEW ENGLAND
PROPELLER**

Along with **CAPEWAY WELDING**
at the Plymouth Industrial Park

Distributors of Michigan Propellers

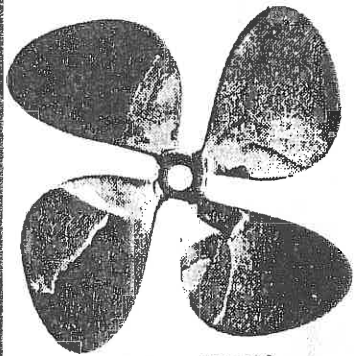

DYNA-QUAD®

- Large inventory of Inboard, Outboard, Stern Drive Props
- Authorized Michigan Repair Center
- Exclusive Pitch Blocks with Guaranteed Accuracy

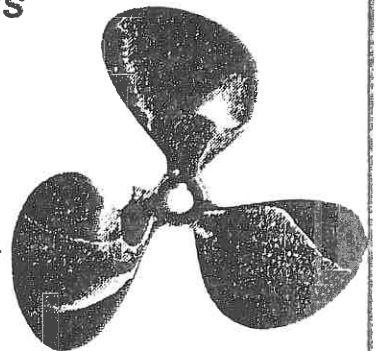

DYNA-JET®

Fast and Quality Repairs for Commercial Fishermen

- Struts • Rudders • Godfrey Zinc Corrosion Collars
- Bronze & Stainless Shafting • Bearings • Flexible Couplings
- Fabricated metal parts for Boating Industry
- Replacing Lower Unit Skegs
- Welding and Machine Shop Service

At Our Plymouth facility, we have a large inventory of marine aluminum pipe, tubings, angle, flat bar and channel; also plate and sheet stock. We have: 1/2" x 10' shear - 14'x225' Ton Brake - Pipe Bending up to 2" Sch. 80.

**New England
Propeller, Inc.**

68 Von Hillern St.
(Off Dorchester Avenue)
Boston, MA 02125

(617) 288-3132

**NOW 2
LOCATIONS
AVAILABLE**

**Capeway
Welding, Inc.**

9 Apollo Eleven Road
Plymouth Industrial Park
Plymouth, MA 02360

(508) 747-6666

NEW ENGLAND PROPELLER
HAS RECENTLY EXPANDED,
ADDING EXPERIENCED STAFF
AND NEW EQUIPMENT TO

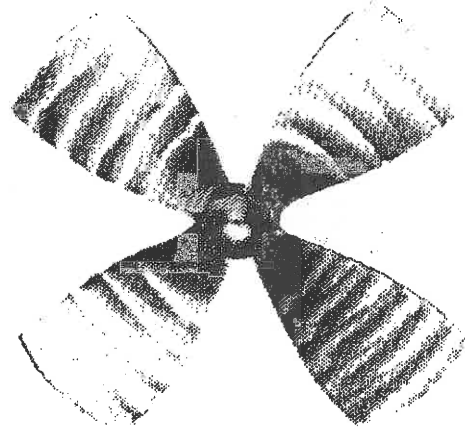
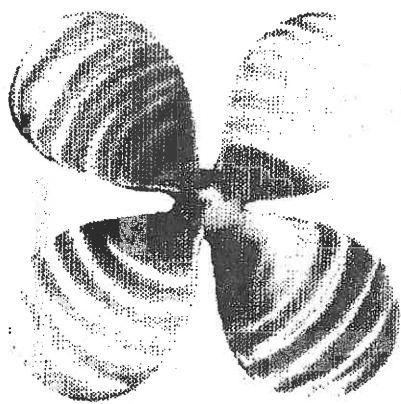

REPAIR PROPELLERS UP TO 8 FT.

IN DIAMETER. FAST, QUALITY

SERVICE AT AFFORDABLE PRICES.

9 APOLLO ELEVEN RD. PLYMOUTH, MA.

(508) 747 - 6666

EXTREME PROTECTION



EXTREME 4000 Hooded Jacket

Adjustable Drawcords

They stay out of your way inside the hood.

Cord Locks

Adjust even while wearing gloves.

Face Flap

Stows securely beside the hood.

Double Cuff Construction

Wears longer and reduces chafing.

The revolutionary hood design of our jacket offers the very best face protection for people who must face the elements head on.

This is still the heaviest weight, longest wearing raingear that you will ever own.

Works equally well with a baseball cap or hard hat.

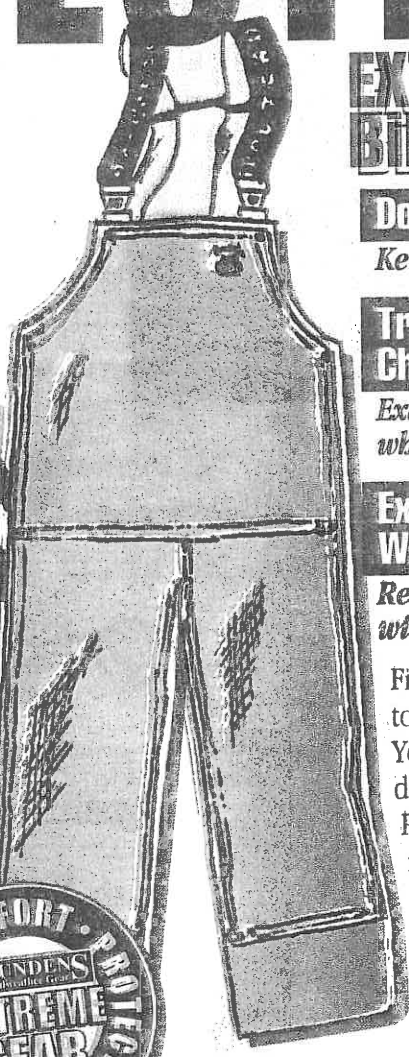

EXTREME 1600 Bib Pant

Double Layer Front

Keeps you dry, even if torn!

Triple Layer Chest / Midsection

Extreme abrasion resistance where it's needed most.

Exclusive Nylon Webbing

Reinforces the pant hem without trapping water.

Fishermen will not find a tougher bib pant on the planet. You'll find the *Extreme 1600's* double sacrificial layer of PVC/Nylon where you need it most to slow wear and keep you dryer longer.

Call your local Marine Gear Supplier or contact us for the supplier in your area.



GRUNDÉNS

The Fisherman's Choice in Foulweather Gear

800-323-7327 • Fax 360-779-8171

Grundéns USA Ltd. • Box 2068 • Poulsbo, WA 98370

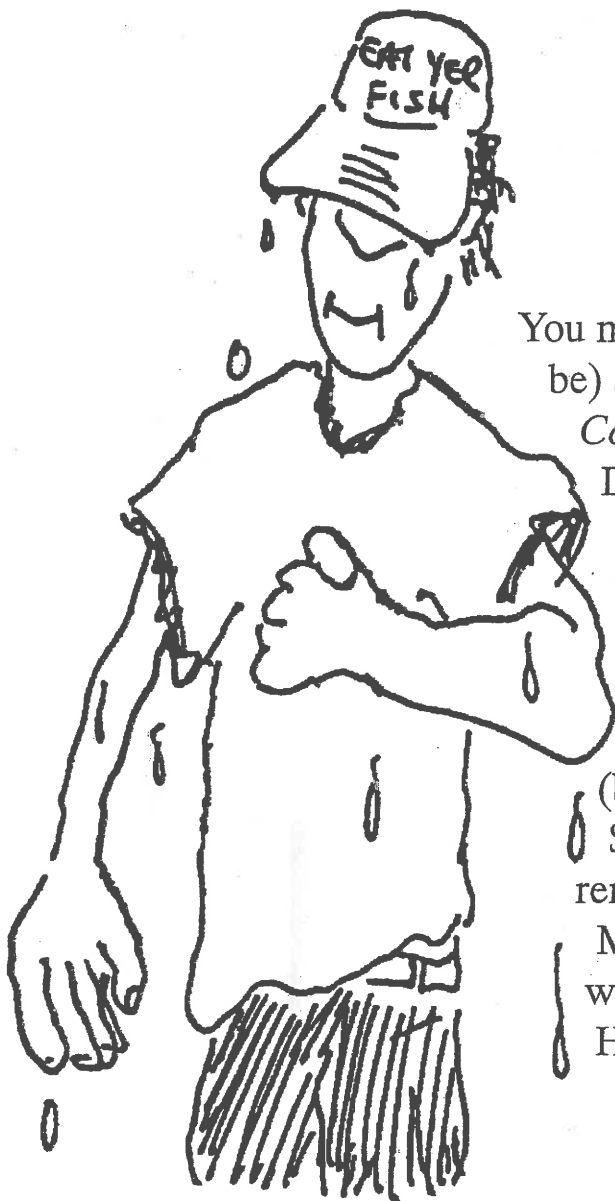

Jumpin' Jeehossafats! We thought we lost you.

You may have gotten a notice lately (or you will be) asking you to re-up your subscription to *Commercial Fisheries News*.

Don't worry you still have a month or two to go. But, instead of renewing with your membership dues we can renew you directly this year.

If you want to renew, clip out the coupon below and send it in with your \$18.95 (being an MLA member saves you more than \$14 a year off the cover price!). If you have a renewal notice in hand, just jot down your MLA membership number on it and return it with your \$18.95. Easier still, gives us a call.

Have your membership number and credit card number ready and we'll renew you over the phone.



Thanks

CLIP & MAIL TO: COMMERCIAL FISHERIES NEWS, PO BOX 37, STONINGTON, ME 04681

Name _____

Address _____

City _____ State _____ Zip _____

MLA membership # _____

Charge my VISA MasterCard AmEx Discover

Acct# _____ Exp Date _____

Signature _____

1 year \$18.95

2 years \$36.00

CALL US AT 1-800-989-5253 OR FAX US AT 207-367-2490



Washington Mutual

HOME LOANS

Home Loan Discount Program for MLA Members Only

Who is eligible?— All members of the Massachusetts Lobsterman Association and Affiliates.

Property Types: First Mortgages for Single Family Homes, Multi Family Homes, Second Homes, and investment properties.

Purchase or Refinance!

Discount Equal to approximately **.250%** off prevailing rates
or
the cash equivalent to be used towards closing costs!

This above program is offered through Paul Ames and Washington Mutual Bank. I am the son of a second generation Commercial Fisherman, who has been a member of the MLA for over 20 years. I personally received a scholarship from the MLA in 1987 and went on to Graduate from the University of Massachusetts at Boston. I am offering my services at a discount to help Lobsterman and Fisherman all over the State of Massachusetts and New England to save money on their home loans.

For more information, please contact:

Paul J. Ames
Loan Consultant



Washington Mutual Bank
Paul J. Ames
Office (617)786-8200 x238
Cell Phone(617)877-5499
1266 Furnace Brook Parkway Suite 201
Quincy, Ma 02169



Capital Construction Fund Investment Management

Smith Barney Asset Management
Money Management
Credit and Lending
Stocks
Mutual Funds
Government Securities
Corporate Bonds
Tax-Free Bonds
IRA's and Pension Plans
Annuities

For more information, contact:

Robert G. Mennona
Vice President—Investments

E. 140 Ridgewood Avenue, 4th Floor
Paramus, NJ 07652

(201) 967-2106

(800) 631-1607

ssbfcs.com/Robert_Mennona

SALOMON SMITH BARNEY®

SEE HOW WE EARN ITSM

Salomon Smith Barney is a registered service mark of Salomon Smith Barney Inc.
"SEE HOW WE EARN IT" is a service mark of Salomon Smith Barney Inc.
© 2001 Salomon Smith Barney Inc. Member SIPC

A member of  Citigroup

12986 Salomon Smith Barney
Farrington & Favia
Job No.: 415 Size: 7½" x 10"
Description: Capital Construction Fund...
June01/SalomonSmithBarney/12986-D-03
6/8/01 jn Proof 5 4 3 2 1

MARINE

Over 10 Years Experience
All Materials & Sizes

Propeller Service

BIG & SMALL

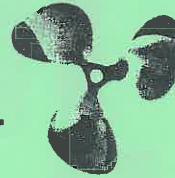

Repaired & Reconditioned ♦ Pick-Up & Delivery

HYDRAULIC HOSE ASSEMBLIES MADE ON PREMISES

 **FAST SERVICE**

 **FULLY INSURED**



AUTHORIZED DEALERS FOR OVATEK RIGID LIFERAFTS

Call Mike at (508) 979-8000

Fax: (508) 996-3785

128 Grinnell Street • New Bedford, MA 02740

Attention Lobstermen!

(Plans also available to small groups and employees)

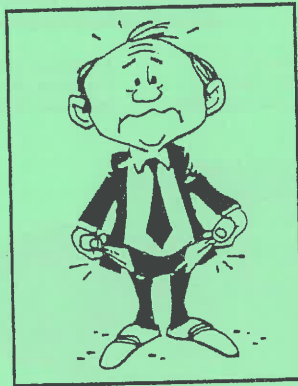

*Going broke over
health care costs?*

**Finally...
Affordable, Endorsed
Health Insurance!***

- ☛ Group rates (Seven Hundred Thousand Members)
- ☛ Any doctor, any hospital, worldwide
- ☛ Custom tailored to your needs
- ☛ Flexible to fit your budget
- ☛ Complete family coverage
- ☛ 100 additional corporate benefits through Association Membership

Call today for a no obligation quote!

*Group Insurance is underwritten by the Mega Life and Health Insurance Company Oklahoma City, Oklahoma



National Association for the self Employed

M/MA0006

Craig O'Donnell
Benefits Coordinator

800-726-1841 ext. 219

24 hr. message center

Introducing the *New* CAT® 3126B.

Head of Its Class.

The electronically controlled fuel system makes it the most technologically advanced engine in its class.

3126B Features

- Electronically controlled fuel system
- Best fuel economy in its class lowering your operating costs
- High horsepower-to-weight ratio
- 420 or 450 HP @ 2800 RPM

The new CAT 3126B marine engine is the most technologically advanced engine in its horsepower class. With its exceptional acceleration characteristics, you'll be able to reach cruise speed faster, shortening your haul time. And, its high horsepower-to-weight ratio and optimum fuel efficiency at any speed will lower your operating costs and increase your profits.

In ME and NH call
Stewart Tuttle at 207-885-8082 or 207-989-1890.
In MA and RI call Don MacPhee 508-634-5533.



Power Systems Division

www.southworth-milton.com

NINE LOCATIONS
THROUGHOUT
THE NORTHEAST

Milford, MA / 508-634-3400
Clifton Park, NY / 518-877-8000
Hopkinton, NH / 603-746-4611

Warner, NH / 603-746-4671
Brewer, ME / 207-989-1890
Scarborough, ME / 207-883-9586

Richmond, VT / 802-434-4228
Cranston, RI / 401-946-6350
Wareham, MA / 508-291-1200

