

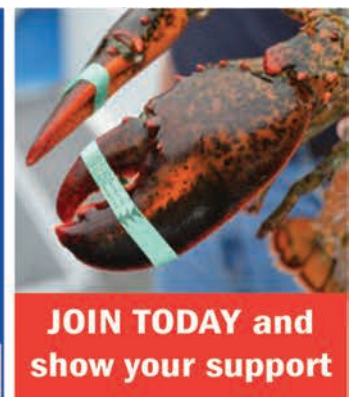

MASSACHUSETTS LOBSTERMEN'S ASSOCIATION

A LEADING Commercial Fishing Industry Association in New England



JOIN TODAY and
show your support

FEBRUARY 2023 NEWSPAPER • WWW.LOBSTERMEN.COM

Massachusetts Lobstermen's Association Annual Weekend & Industry Trade Show March 24-26, 2023

SEE
PAGES
17 - 24
FOR MORE
INFO!

We are ready, are you? Are you ready for some fun, laughs and great conversations at this year's Massachusetts Lobstermen's Associations' 60th Annual Weekend and Industry Trade Show March 24-26th at the Resort and Conference Center at Hyannis, 35 Schudder Ave., Hyannis, MA 02601. We are thrilled to be back, and the Annual Weekend Committee has been working hard over the last several months to ensure this year's event is the best one yet. In this paper you find most of event's offerings from; 3 comedians Friday night, raffles, Member gifts, MLAs infamous hospitality suite, all the great seminars, the 50 plus vendors, and all the other great offerings.

If you have not yet reserved your booth or hotel room or meal tickets, please do not delay any longer as we



are almost at capacity. All the forms can be found on the MLAs website www.lobstermen.com

Admission to the Trade Show is FREE so, come on down for the day

or spend the weekend, we are happy to be back out in in the world where we can all see each other after three long years in hibernation. See you there!



SERIOUS ABOUT SAFETY

LRSE.COM | 401-816-5400

590 FISH RD, TIVERTON, RI 02878
 181 OLD COLONY AVE, UNIT A, BOSTON, MA 02127
 55 STATE ST, NARRAGANSETT, RI 02882



SALES • SERVICE • TRAINING • RENTAL • OUTFITTING • PICKUP + DELIVERY

Safety Equipment Servicing

Life Raft + Survival Equipment has been selling and servicing all major brands of Life Rafts, EPIRBs/PLBs, Life Jackets, Immersion Suits, and Man Overboard Equipment since 1983.

We offer pickup and delivery to over 20 locations throughout the Northeast.

CALL FOR GREAT PRICING.

North East Safety Training

NEST, a division of LRSE, offers hands-on Basic, Advanced, and Customized Safety Training Courses, Monthly Drill Conducting, First Aid/CPR/AED Courses and Vessel Inspections.

VISIT OUR WEBSITE TO LEARN MORE.

-  LIFE RAFTS
-  EPIRBs + PLBs
-  LIFE JACKETS
-  IMMERSION SUITS
-  MAN OVERBOARD
-  PICKUP + DELIVERY

COMMERCIAL LIFE RAFTS

Elliot, Zodiac, Crewsaver, Revere, Viking



FIBRELIGHT LADDERS

Man Overboard Recovery Cradle, Self Recovery Ladder



IMMERSION SUITS

Imperial



EPIRBs

ACR V4



FIRETKO®

Fire Suppression Tool



LIFE JACKETS

Mustang



MLA Sponsors

The following companies are proud supporting MLA members. We encourage our members to patronize them. If your company is not listed and you would like it to be, contact Tracey Abboud at 781-545-6984, ext. 2

ALIVE & KICKING LOBSTER
LOUIS MASTRANGELO
CAMBRIDGE, MA
617.876.0451

BAR HARBOR LOBSTER
JEFF HAZELL
ORLANDO, FL
407.851.4001

BOSTON LOBSTER
NEIL ZARELLA
617.464.1500
bostonlobstercompany.com

BOSTON SWORD & TUNA
STEPHEN SCOLA
BOSTON, MA
617.946.9850

BROOKS TRAP MILL
STEPHEN BROOKS
THOMASTON, ME
207.354.8763
stephen@brookstrapmill.com

CAPE ANN MARINE
SALES & SERVICE
978.283.0806
CapeAnnMarina.com

C-TRAP
MATT BORGES
MATTAPOISETT, MA
508.758.2740

CAPE SEAFOODS
BAIT DEALER
GERRY O'NEIL
GLOUCESTER, MA
978.479.4642

CAPE FISHERMEN SUPPLY
DAVE LIBBY
CHATHAM, MA
508.945.3501

CAPE TIP SEAFOODS
CHRIS KING
PROVINCETOWN/ORLEANS
508.487.0259 | 508.225.7221

CAPTAIN MARDEN'S
SEAFOODS
KIM MARDEN
WELLESLEY, MA
781.329.7007 | 781.329.0792
captainmardens.com

CHERRY ST. FISH MARKET
DARRYL PARKER
DANVERS, MA
978.777.3449

CHRIS ELECTRONICS CORP.
FAIRHAVEN, MA
508.994.8257

COASTAL HYDRAULICS
RICH TUCKER
SEABROOK, NH
603.474.1914
coastalhyd.com
sales@coastalhyd.com

COHASSET LOBSTER
POUND
TOMMY ALIOTO
COHASSET, MA
781.383.1551

EAST COAST SEAFOOD
SPIROS TOURKAKIS
LYNN, MA
781.593.1737

ECKLAND & BLANDO
SAM BLATCHLEY
BOSTON, MA 02110
617.217.6936
www.ecklandblando.com

ELECTRA-DYNE CO INC.
JUDY MACCAFERRI
PLYMOUTH, MA
508.746.3270

FARM CREDIT EAST
MIDDLEBORO, MA
508.946.4455

FISHER AIR FASTENERS
ED & CHRIS FISHER
PEMBROKE, MA
781.826.2522

FISHERMEN SERVICES
DONNA CHEPREN
781.545.5073 Ext. 16
fishermenservices.com

FLEET PROPELLER
SERVICE
MIKE VALM
FAIRHAVEN, MA
508.979.8000

FRIENDSHIP TRAP CO.
JERRY WADSWORTH
FRIENDSHIP, ME
800.451.1200

HAMILTON MARINE INC.
56 US ROUTE 1 BYPASS
KITTERY, ME 03904
207.439.1133
hamiltonmarine.com

HARBOR FUELS
info@harborfuels.com
617.720.3835

HERCULES
JOHN REARDON
NEW BEDFORD, MA
508.993.0010

JAMES HOOK & CO.
ED HOOK JR.
BOSTON, MA
617.423.5500

JOHN M. KARBOTT
CUSTOM
WOODEN BOAT
BUILDING & REPAIR
PLYMOUTH, MA
508.224.3709
by-the-sea.com/
karbottboatbuilding

KETCHAM TRAPS
HEATHER KETCHAM
NEW BEDFORD, MA
508.997.4787

KINGFISHER TRAP
CARL HOWARD
DENNIS, MA
508.385.5968

KING LOBSTERS
D.J. KING
BRANFORD, CT
203.488.6926

KING MARINE LLC
CAPT. GEORDIE KING
MARINE SURVEYOR
207.337.8706
kinggeordie@comcast.net

LOBSTER CRUISES
PAUL QUINTAL
PLYMOUTH, MA
508.746.5342

LOBSTER TRAP
FISH MARKET
MONUMET BEACH, MA
508.759.6400
lobstertrap.com

LOBSTER TRAP CO.
LOGAN CLARK
BOURNE, MA
508.759.4928
lobstertrap.com

LYNCH LOBSTER CO.
JOHN LYNCH
BEVERLY, MA
978.921.8088

MAIN STREET WIRE
DOUGLAS, MA
508.847.8888

MARINE HYDRAULIC
ENGINEERING
ROBERT CROWE
ROCKLAND, ME
207.594.9525 | 800.747.7550

MILTON CAT
POWER SYSTEMS
NICK FAWEL
MILFORD, MA
508.207.8542

MORTILLARO LOBSTER,
INC.
VINCE MORTILLARO
GLOUCESTER, MA
798.281.0959

NAHANT FISH & LOBSTER
781.592.7500

NAPA-CAPE COD
BILL DRINAN
FALMOUTH, MA
508-457-1734

NAVROC MARINE
ELECTRONICS
JASON PHILBROOK
ROCKLAND, ME
207.596.7803

N.E. MARINE &
INDUSTRIAL INC.
MIKE RICHARDSON (NH)
603.436.2836 | 781.834.9301
Info@newenglandmarine.com

NEW ENGLAND PROPELLER
RON PECK
PLYMOUTH, MA
800.635.9504
neprop@aol.com

NORTH ATLANTIC
POWER-TWIN DISC
SAM PROFIO
EXETER, NH
sprofio@glpower.com
603.418.0470

PIGEON COVE COOP
ROBERT MORRIS
978.479.3828

RFP LOBSTER BAIT
DICK PERENTZ
774.248.0292

RIVERDALE MILLS
NORTHBRIDGE, MA
508.234.8715

ROSES MARINE
MARTY BOLCOME
GLOUCESTER, MA
877.283.3334
rosesmarine.com

SEA CLIFF LOBSTER
FRANK COLLINS
MANOMET, MA
508.224.5700

SPURS MARINE MFG.
PABLO SOSA
FORT LAUDERDALE, FL
800.824.5372

SUPERIOR LOBSTER
MARSHFIELD-SANDWICH
774.773.5048
www.superiorlobster.com

THE NEW RESULT
LOUIS LARSEN
Mvseafood@vineyard.net

TWO COUSINS
FISH MARKET
BRIAN O'DONOHUE
FREEPORT, NY
516.379.5065

WELLFLEET
SHELLFISH CO.
508.255.5300
sales@wellfleetshell.com

WINDWARD POWER
SYSTEMS
FAIRHAVEN, MA
774.992.0059
windwardpower.com

WOOD'S SEAFOOD
JAY KIMBALL
PLYMOUTH, MA
508.746.0261
www.woodseafood.com

YANKEE FISHERMEN'S
CO-OP
SEABROOK, NH
603.474.9850

IN MEMORIAL



John Coville

It is with heavy heart that we must inform you that MLA member John Coville passed away. John fished out of Humarock on the f/v Cloud Nine for many years and will be greatly missed. May you sail on calm seas and your pots be forever full.

IN MEMORIAL

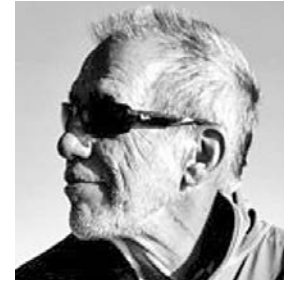

Jay Anthony Harrington

Longtime MLA member, Jay Anthony Harrington, 71, of South Orleans, died on December 31, 2022 of a neurodegenerative disorder. Born in Somerville, MA. on January 3, 1951, Jay was the fourth and youngest child of William and Jadwiga Harrington. The family lived in Charlestown, MA, then Brighton, MA before moving to Stoughton, MA where Jay attended school, graduating from Stoughton High School in 1968.

In 1971, Jay moved to Cape Cod where he lived and worked in South Orleans for the next 50 years. He was skilled in carpentry and spent 9 years living as a year-round caretaker on Sipson's Island starting in 1972. This was the start of a journey that fostered a love, deep understanding and respect for nature, encompassing a truly unique relationship with the waters of Pleasant Bay, both over and under the waves. Jay was able to make his living as a commercial fisherman by shell-fishing and fin-fishing in Pleasant Bay and the areas around Monomoy Island for his entire adult life. Looking towards the future, he received his Master's (Captain's) license in 2015 for vessels under 25 GRT, planning one day to perhaps introduce others to the wonders of Pleasant Bay. Jay never took the beauty of his surroundings for granted and always felt that every day on the water was a day well spent, no matter what the conditions. May he forever sail on calm seas.

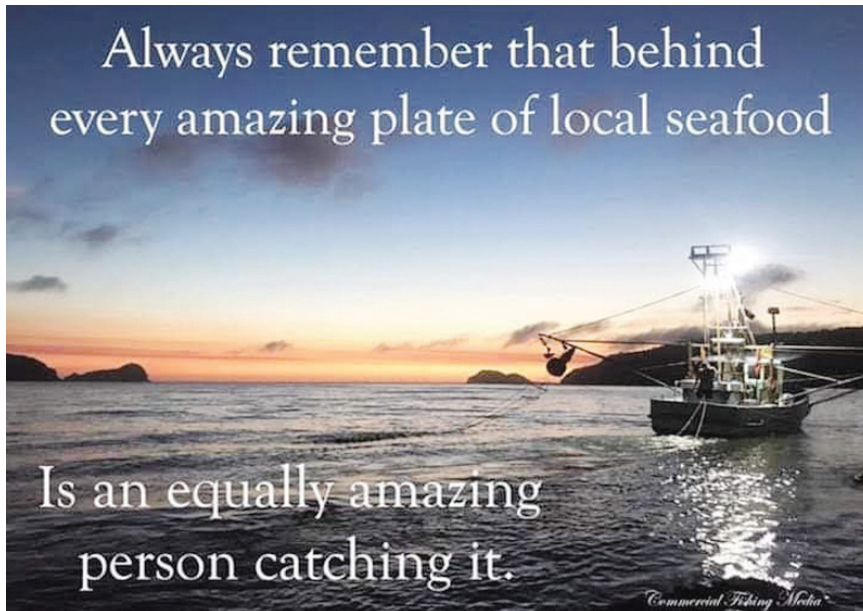

fisheryfriendlyclimateaction.org

Fishery Friendly Climate Action

A grassroots campaign led by fishermen, for fishermen, to promote climate action that works *for* fisheries and not at our expense.

Sign up for our email discussion list!

VISIT OUR BOOTH AT THE MLA ANNUAL WEEKEND!

Next Webinar: February 21, 5:00 pm ET: "Fishermen, farmers, and climate action: Are there opportunities for mutual wins?"



**HAMILTON
MARINE**
BOATERS' STORE!™

VISIT ONE OF OUR SIX MAINE LOCATIONS

With six established locations along the Maine coast, Hamilton Marine is a must-shop for boating enthusiasts, fishermen, boat builders and inquiring travelers to Maine. Don't know what part you need to get the ol' gal going again? Looking for the best outerwear to keep you comfortable on the water? Need a gift for the fisherman in your life? **We're here to help!**



**NEW
2023
CATALOG
COMING IN MARCH!**



Commercial



Anchoring



Safety



Antifreeze



Gear



Electronics



Heaters

800-639-2715 • HAMILTONMARINE.COM

KITTERY | PORTLAND | ROCKLAND | SEARSPORT | SW HARBOR | JONESPORT



Service Provider for MLA Non-Profit Boat Protection Cooperative Ltd.

MLA's #1 Commercial Boating Insurance Provider

Agreed Hull Value – Protection & Indemnity

Crew Coverage - Extended Policy Limits - Chartering

Marina Floaters - Multiple Fisheries - Deductibles

Call now for a free quote 781-545-5073

or

Request a quote online at fishermenservices.com



The Massachusetts Lobstermen's Association would like to welcome the following new members to the Association. Your Association will continue its efforts on your behalf to conserve the resource, protect your livelihood, keep you informed, promote the industry and provide you with increasing benefits as they are developed. MLA stands ready to help you in anyway, at anytime — just let us know how! Safe on the water and good fishing!

NEW MLA MEMBERS:

THOMAS COLBERT

Blondie • Port: Sandwich

CHUCK MORICI

Act #1 • Port: Montauk NY

CHAD OSBORNE

Caitline Christine • Port: Gloucester

SONNY RAY RICH

Susan Elizabeth • Port: Portland ME

MARK SAWYER

Gotcha • Port: Plymouth



Published by the Massachusetts Lobstermen's Association, Inc.
8 Otis Place, Scituate, MA 02066

– Published monthly –

Mailed to all paid members of the Massachusetts Lobstermen's Association

Newsletter Departments

Editor, Industry News, Notice Section, Editorial, Blog, Industry News, Promotions, Layout, Advertising:
Beth Casoni — Executive Director

Buy Sell Swap: Tracey Abboud

Newsletter Advertising Rates

The MLA Newsletter is published monthly
(Please note that all pre-paid ads for last year will be honored)

\$50 — ¼ Page Ad

\$80 — ½ Page Ad

\$110 — Full Page Ad

Color Ads — + \$50 per ad

As the HAULER TURNS

I really thought this month, I was only going to be talking about the exciting, long overdue and, upcoming Massachusetts Lobstermen's Association Annual Weekend & Industry Trade Show (MLAs Annual Weekend) and here we are consumed with more unwarranted stressors and costly litigation caused by the Federal Government and right whales. Right whales continue to dominate all of our time, energy and, funds to keep you fishing and it must be noted that there have been 0 deaths and 0 serious injuries attributed to Massachusetts lobster gear.

After last month's onslaught of even more right whale litigation, if you can believe that, the MLA filed a lawsuit against NOAA and NMFS on February 1, 2023, for their enactment of an emergency closure of the wedge on the North Shore. There was nothing documented, no right whale sightings, to warrant this action seeing that the right whales were showing up in lower Cape Cod Bay and not the North Shore. The MLAs' counsel is fighting on your behalf as the government is exploiting the recently released Omnibus Bill with the language baked into it that noted "No New Rules" and this is just that, a NEW RULE.

All of the legal filings can be found on the MLAs website under Right Whale Litigation and Management updates. Once the MLA knows more

we will be sure to update you all. If you do not receive MLA Members direct emails from me, please send me an email to, beth.casoni@lobstermen.com, and ask to be added to the MLA Members email list. I really thought the MLAs legal battles were waning, how naive am I?

As the legal bills are coming in and with this new lawsuit on the table, the MLA Legal Defense Fund needs your help more now as we are still embroiled in the Maine Lobstermen's Associations lawsuit as an intervenor. You can see all the ways to make a donation on the Legal Defense Fund updates in this paper. The MLA is fighting for you at every turn and now we are taking a stand against the exploitation of the language in the Omnibus Spending Bill.

When it comes to right whale conservation, Massachusetts commercial lobstermen are leading the way with ALL of the measures you have been fishing under for over 30 years now. The MLA is working through the Lobster Foundation of Massachusetts as they have received a Massachusetts Environmental Trust Fund grant to further help reduce knots in vertical lines. If you have not yet signed up for one of the Splicing Workshops please feel free to call 781-545-6984 xt.4 and leave a message. We are shaking every tree to help get you the resources to help mitigate ALL of the right



whale conservation measures that have been implemented to date.

I must close on a positive note with, the MLAs Annual Weekend as we have been working hard on this to ensure you can come and enjoy all that there is to be had. There are going to be over 50 vendors, seminars to keep you informed on all things industry related, comedians to make you laugh and, lots of time to catch up with your fellow fishermen from around the Northeast. Who couldn't use a good laugh right about now? If I don't laugh, I will cry as you can't make this \$hit up! We look forward to seeing you all there!

As always safe on the water,

Beth Casoni

Director



UNITED STATES DEPARTMENT OF COMMERCE
National Oceanic and Atmospheric Administration
NATIONAL MARINE FISHERIES SERVICE
 Silver Spring, MD 20910

Email to ALWTRT on the implications of the Consolidated Appropriations Act

ALWTRT Members and Alternates,

Thank you all for the constructive input you provided through the Atlantic Large Whale Take Reduction Team (ALWTRT) process that culminated last year. As you may know by now, the Consolidated Appropriations Act 2023 that was passed in December included a mandate that, with limited exceptions, the 2021 Atlantic Large Whale Take Reduction Plan (ALWTRP) amendments “shall be deemed sufficient to ensure that the continued Federal and State authorizations of the American lobster and Jonah crab fisheries are in full compliance” with the Endangered Species Act and Marine Mammal Protection Act until December 31, 2028. The Act also prescribes and provides increased appropriations that support further development and implementation of innovative gear technologies, monitoring in the Gulf of Maine, and for other purposes.

Under these new provisions, we are required to “promulgate new regulations for the American lobster and Jonah crab fisheries consistent with the Marine Mammal Protection Act of 1972 (16 U.S.C. 1361 et seq.) and the Endangered Species Act of 1973 (16 U.S.C. 1531 et seq.) that take effect by December 31, 2028.” Though this is a different timeline than was discussed during the last ALWTRT meeting, I want to assure you that we will use input from your recent deliberations as a guide as we develop additional modifications to the Take Reduction Plan over the next several years. Further, we will consider new information as it becomes available and are considering how and when to re-engage with the ALWTRT in the future. In the short term, we anticipate moving forward with an extension of the emergency rule closing the “wedge” area surrounded by the Massachusetts Restricted Area. We also anticipate a proposed rule modifying the gillnet and other trap/pot fisheries.

We will continue working diligently to develop and expand use of on-demand fishing and other gear modifications. This requires that we work closely with the States, Councils and Commission, in consultation with fishing industry participants and others, on implementation challenges such as modifying surface marking requirements to include geolocation or other bottom gear marking techniques that can work as well as buoy lines to prevent gear conflicts. We will also explore solutions and challenges to implementing line caps and a dynamic approach for opening seasonal restricted areas or dynamic closures.

Funds appropriated for right whale research will be used to inform our understanding of right whale distribution, habitat use, health, threats, and other factors that will improve the models used to describe, predict, and analyze the changing risk landscape facing the North Atlantic right whale. The Decision Support Tool updates will go through peer review January 30 through February 1, which the Team is welcome to attend. We will share a webinar link and agenda next week.

While the new provisions of law have changed our trajectory and we are still considering the recent TRT input and recommendations, we plan to shift our energy into developing the next set of rules, as opposed to convening and managing the Team. Regardless, over the next year, we anticipate providing regular email and webinar updates on various topics of particular interest to the Team, such as the Decision Support Tool peer review results, abundance and trends, status of the NARW UME, and news on other recovery actions (e.g., vessel speed regulations) to keep you apprised of new information as it arises.

Thank you again for all of your hard work. As always, we are committed to using funds effectively and working with all of you to recover North Atlantic right whales and meet our goals under the MMPA.

Sincerely,

Janet Coit



FISHING PARTNERSHIP



SUPPORT SERVICES

NAVIGATOR OFFICES



Gloucester
978-282-4847



New Bedford
508-991-3043



Plymouth
508-746-5400



Chatham
774-840-9393

Connecting You to Massachusetts Health Insurance Year-Round

2023 Open Enrollment
Nov. 1, 2022 - Jan. 23, 2023

Fishing Partnership Navigators can help any MA resident under 65 access health insurance. A Navigator can assist you with applying for coverage, renewing your plan, making changes to your application, or shopping for a new plan.

Contact a Navigator anytime during the year to apply or make changes to your application.

Apply by Jan. 23 to have coverage that begins Feb. 1.

Massachusetts maintains a mandate for all individuals to have health insurance. Unenrolled residents could pay a tax penalty. Don't risk it - call a Navigator and get covered today!

Scan to Request
Health Insurance Services

Follow



617-928-3443
fishingpartnership.org



Visit MAHEALTHCONNECTOR.ORG
for more information



AQUAMESH®

by Riverdale Mills

Still Making History



**Proudly Made
in the USA
Since 1980**

Our History, Your Legacy

A tribute to the revered Riverdale Aquamesh®

Aquamesh® features high strength steel wire, the heaviest zinc coating, and Riverdale's proprietary marine grade PVC coating. Aquamesh® is pure and simple. It is the best; designed for you, designed to fish.



+1.508.234.8715
sales@riverdale.com
RIVERDALE.COM

Ocean Carbon & Biogeochemistry Workshop

— January 18, 19, 20, 2023 —

WORKSHOP TITLE : Building a cost-effective coastal biogeochemical observed network in collaboration with the commercial fishing community.

If all this doesn't get you excited, I don't know what will!? The government has a unique way to get us excited to jump right in and participate! Right!!

Regardless of the initial introduction, this workshop proved to be of value to the commercial fleet. The MLA was represented by me and David Marsh, F/V Grace Sarah, Sandwich, MA.

Commercial fishers in attendance included scallopers, long liners, trawlers, gillnetters, clammers and Maine lobstermen! Industry representatives from around the U.S. (Mid-Atlantic, Gulf of Mexico, West Coast and Alaska.) As well as Europe and New Zealand were represented. All were and have been involved in co-operative ocean data gathering with scientists.

Science was represented with Woods Hole Oceanographic Institute, NOAA, Northeast Fisheries Science Center, Ocean Data Network, Inc., Commercial Fisheries Research Foundation, NERACOOS, and Ocean Observatories Initiative.

The Pioneer Project e-molt (electronic monitors on lobster traps) has involved hundreds of lobstermen over decades, with temperature monitors on our traps. This has expanded into greater monitoring of the marine eco-system using a wide variety of scientific instruments recording a wide variety of observations.



WOODS HOLE
OCEANOGRAPHIC
INSTITUTION



The most recent being the monitoring of dissolved oxygen and hypoxia in Cape Cod Bay. All the involved participants broke off into “working groups”, (what else?!) to try and find new ways to both expand and refine current observations.

Scientists wanting to know what additional observations the fishers would like to see and the fishers wishing to have clear and quick informative feedback on the observations!

The consensus was to expand research, co-ordinate existing information, share projects and results! Sounds simple enough! Again—Right!

Examples of shared info- We found out that a low dissolved oxygen bloom (blob) affected the crab fisheries off the coast of Oregon last year! Expanded studies between the Cape Cod Bay (MA

DMF) and Oregon might lead to a better understanding of our ability to predict future events!

Industry has a responsibility to involve itself in monitoring the marine eco-system with the end result being a better understanding of their product of direct harvesting, being, lobster, fish or shellfish!

Science on the other hand must work to develop observation equipment that is simple to deploy and understand the results of observation.

For the most part the commercial fisheries wished to know current and long-term observations involving, temperature, salinity, acidification, current dissolved oxygen, and any other factors that might affect our target species! Not too much to ask! The science community is very willing to work with industry on all levels.

Of course, time is money! Some of these observations can be done without much time or effort! Others will require greater involvement! Both science and industry agree funding is necessary!

Industry has had a reluctance to involve itself in a lot of ocean observations projects over the years! The fear that their observations and information will bounce back and “bite them in the ass” with management restrictions! This has not been the case within the past few years, science and industry over time have saved fisheries! Our industry suffers from pressure not related to marine eco-system observations and research.

If you are asked to participate in a co-operative study involving direct observations using your vessel and time, know what is being studied, what is your time and effort involvement, how will this help you or industry in the long term, and is this a worthwhile project to help the commercial fishing industry?

Do not confuse the testing of equipment, scientific harvesting material or related projects with observation of existing projects and equipment!

How can we make it work better for us as harvesters, not corporate profits. You can make that decision!

There will be ongoing projects and research in the near future-get involved-it is your future!

Any questions or ideas, let me know.

Dave Casoni
MLA Secretary/Treasurer



Mission critical.

Visit us at the
MLA's Annual Weekend.

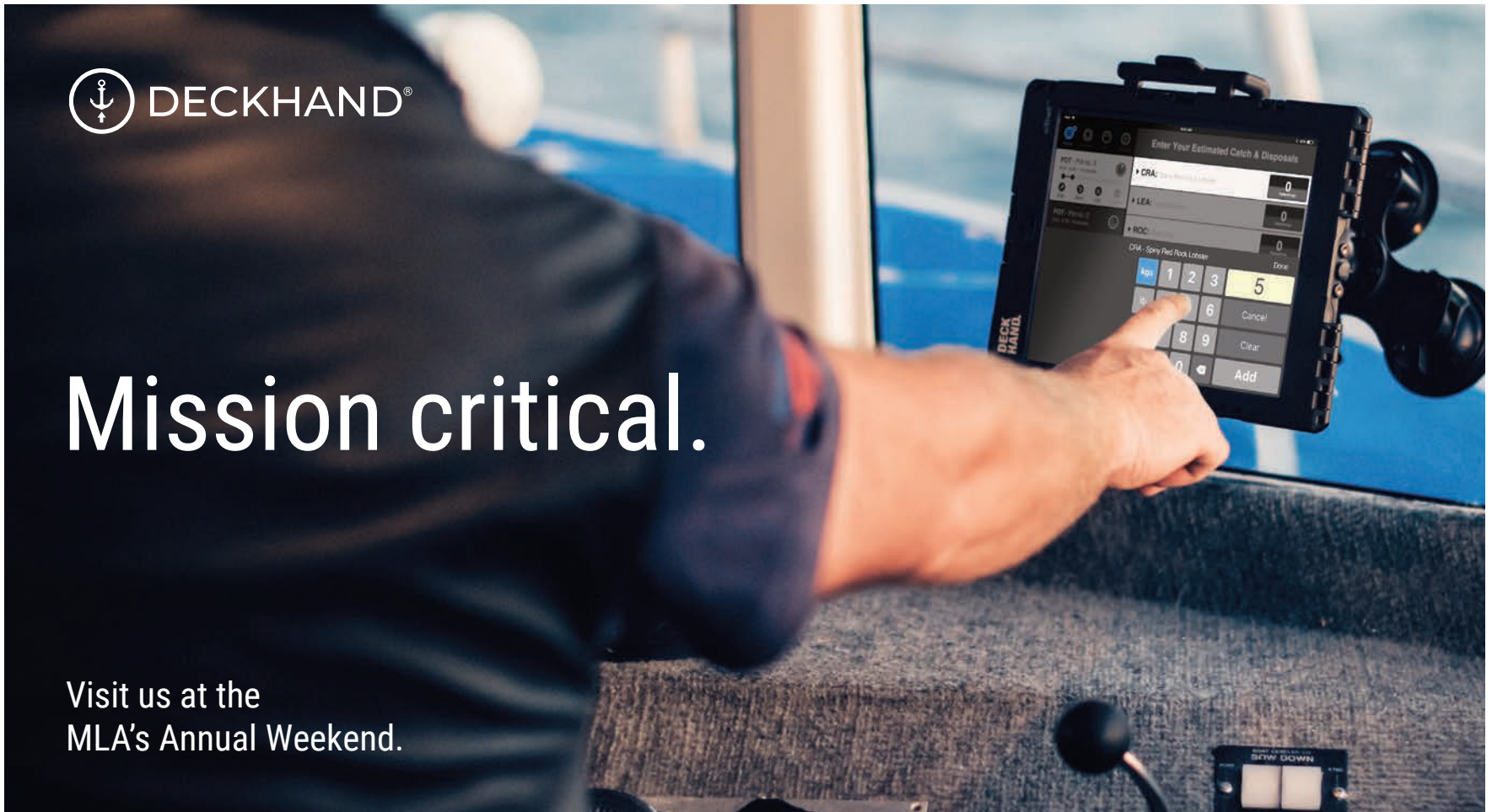

Are you thinking of buying or selling?

Boats | State and Federal Permits | Complete Businesses

ATHEARN MARINE AGENCY, INC.



SERVING FISHERMEN SINCE 1946

Tel: (508) 999-4505
Email: sales@athearnmarine.com
www.athearnmarine.com

10 Union Wharf, Fairhaven, MA 02719





New England Marine Engineering & Supply, Inc.

Marine • Industrial • Commercial • Refrigeration

10 TON ELECTRIC TITANIUM RSW
INTEGRATED MARINE SYSTEMS

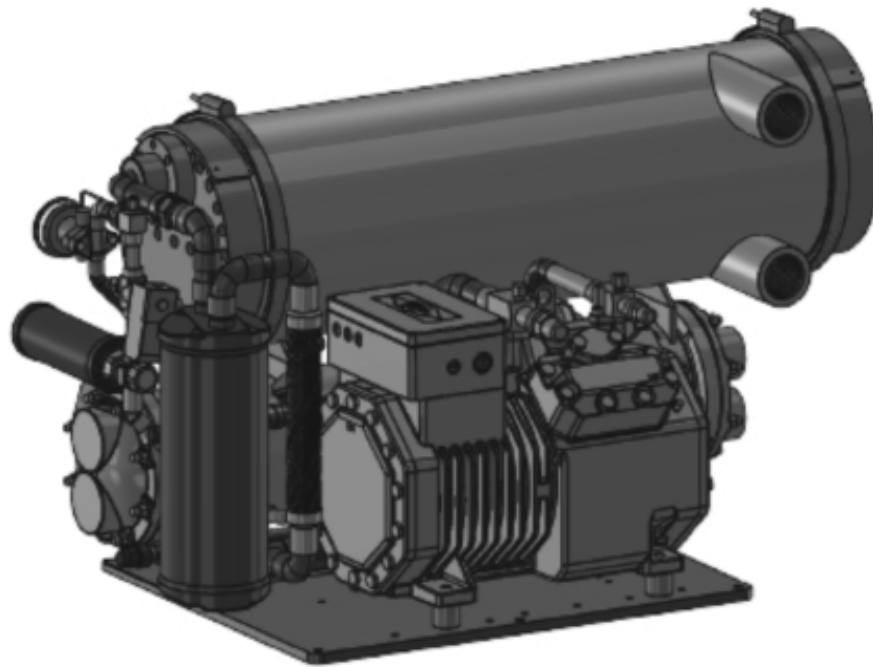

"New England Marine Engineering & Supply, Inc & Integrated Marine Systems, Inc is proud to announce & debut the new IMS 10 Ton Titanium Electric RSW at the 2018 Seafood Processing North America Show on March 11-13 Booth 1875. Come see us and be the first to view the latest IMS system to be introduced to the industry for the fishing vessels ranging from 40' - 80'.

It's going to be the talk of the show."

133 North Front Street, New Bedford, MA. 02740

www.nemesinc.com 1.800.540.8893



New England Marine & Industrial
www.newenglandmarine.com

Lobster Bands

We carry:

Sheddar

Standard

Cold Water Shedder

Jumbo



Buy them by the 1 pound bag, by the case or by the pallet. We also offer wholesale and volume discounts. Call and ask to speak to a salesman.



Dayglo &
Flexabar
Buoy Paint



Perone Buoys

Full selection of sizes
in Stock

Riverdale/Aquamesh Trap Wire

- Large inventory of trap wire in store
- Variety of sizes and colors available
 - Some trap kits in stock
- Order any size trap kits you may need

200 Spaulding Tpke
Portsmouth, NH
603-436-2836

294 Ocean St
Brant Rock, MA
781-834-9301

86 Cemetary Rd
Stonington, ME
207-367-2692



New England Fishery Management Council

FOR IMMEDIATE RELEASE
January 24, 2023

PRESS CONTACT: Janice Plante
(607) 592-4817, jplante@nefmc.org

Council Executive Director Tom Nies Announces Retirement

The New England Fishery Management Council opened its January 24-26, 2023 meeting in Portsmouth, NH with the news that Executive Director Thomas A. Nies, a 25-year veteran of the Council staff, will be retiring this summer. The Council will immediately initiate a nationwide search for his replacement.

Tom joined the Council staff in 1997. He first worked on the Atlantic Herring Fishery Management Plan and then spent 13 years as the Council's lead analyst for groundfish. In that role, he led the Groundfish Plan Development Team (PDT), as he did the Herring PDT beforehand. Tom also helped develop a standardized bycatch reporting methodology for Northeast fisheries. He became Executive Director in 2013.

Council Chair Eric Reid said, "The New England Fishery Management Council has had the rare privilege to have Tom at the helm of what can be, at times, a rather unwieldy ship. On every voyage, Tom's tremendous work ethic and institutional knowledge have been unsurpassed assets not only to the Council members and staff but also to our stakeholders and the public."



"I'm fully committed to the Council process. I've thoroughly enjoyed my job." – Executive Director Tom Nies.

As Executive Director, Tom's many responsibilities have included participating in: (1) the Council Coordination Committee ([CCC](#)), which includes leadership from all eight of the nation's regional fishery management councils; and (2) the Northeast Region Coordinating Council ([NRCC](#)), which, among other tasks, determines the region's stock assessment schedule.

Chair Reid said, "Tom has earned the respect of all of us in New England and nationwide from Gloucester to Guam. He is a true professional, and we'll always be grateful for his strong leadership."

Prior to joining the Council, Tom completed a 21-year career with the U.S. Coast Guard. He logged over 10 years of at-sea duty and served as the Commanding Officer of the Boston, MA-based USCG Cutter Spencer. His land-based assignments included a stint at the fisheries law enforcement branch at Coast Guard Headquarters in Washington, D.C. He later served as the Admiral's representative for the First Coast Guard District Law Enforcement Division at New England Council meetings, which was his introduction to the Council.

The Council will issue a vacancy announcement to solicit a new Executive Director. Tom will overlap with his successor to ensure a smooth transition. Additional information will be forthcoming.



***Cape Seafoods Bait Shop
Kicking off the Season!***

THE LARGEST BAIT VARIETY IN THE ATLANTIC NORTHEAST

In operation since 2001 and still going strong!

Trust Us for Your Fresh, Salted & Frozen Bait Needs

From (1) Carton to a Full Truck Load.

**Herring, Mackerel, Pogies, Redfish, Rockfish, Tuna, Monkfish, Sardines,
Plaice, Squid, Sea Robin, Halibut, & Silversides.**

We've got you covered!

Great News...We now buy Lobster, too!

Open Year Round (Serving clients 7 Days a Week from Mid-June To Mid-October)

Monday-Friday 5AM-3PM, Saturday 6AM-12PM & Sunday 6AM-10AM

Main Phone Line: 978.283.8522

Bait Shop Phone Line : 978.479.4642

If we don't have it... Please ask and we'll find it!

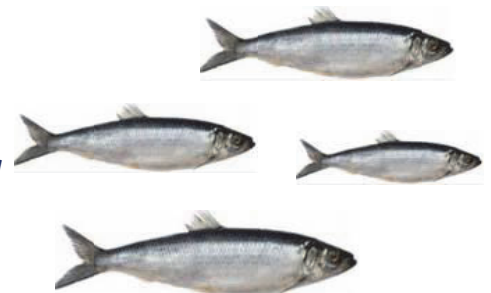

YOUR COMPLETE EVENT GUIDE INSIDE!

See pages 18-24 for the full slate of fun & informative activities for the whole family



2023 Annual Weekend & Industry Trade Show

March 23-26, 2023

AT THE RESORT & CONFERENCE CENTER AT HYANNIS

35 Scudder Avenue, Hyannis, MA 02601 | www.capecodresortandconferencecenter.com



KIDS' ACTIVITIES / ALL ARE WELCOME

Annual Weekend & Industry Trade Show 2023

March 23-26, 2023



Located at the Resort and Conference Center at Hyannis
35 Scudder Ave, Hyannis, MA 02601 | www.capecodresortandconferencecenter.com

A Full Slate of Activities For the Whole Family

- A super exhibition of the latest goods and services that are important to the lobster/fishing industry as well as Government Agencies
- Seminars-Friday and Saturday
- Comedians-Friday evening following dinner
- Craft-Make you own candy bouquet
- Cooking Demonstration-Saturday
- Super MLA Scholarship raffle Fri-Sun
- Banquet Awards Ceremony Saturday evening
- Children's activity room Fri/Sat evening
- There will be many raffles with cash prizes, free drawings and much more!

The Massachusetts Lobstermen's Association is working hard to bring to you the 2023 MLA Annual Weekend and Trade Show with many vendors along with several informative seminars Friday and Saturday.

Even if you're not an MLA member yet!
Come on down, over or up and join us for the event.

Remember, this is your industry
why not join the MLA for some fun?

ADMISSION to the SHOW is FREE

For more information on membership, room packages, seminars and vendor information please visit www.lobstermen.com

Exhibit Hall Hours: Thu. (setup day) 9:00am-5:00pm, Fri. 9:00am-5:00pm, Sat. 9:00am-5:00pm



Arts & Crafts Games



When: Friday & Saturday
Time: 6:00 pm - 11:00 pm
Where: (TBD)

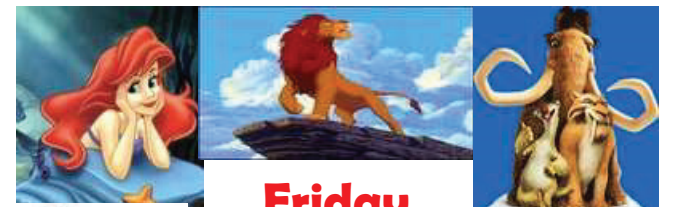

Friday & Saturday Night Movies



Once again, there will be age appropriate activities and movies. Pizza is the food of choice for Friday night and Saturday will be chicken nuggets and French fries, along with non-caffeinated beverages and dessert.

Do not forget to pre-register your child at the MLA booth.

All children MUST be picked up by 11:00 PM. Thank you!



COMEDY SHOW / GRAND BUFFET

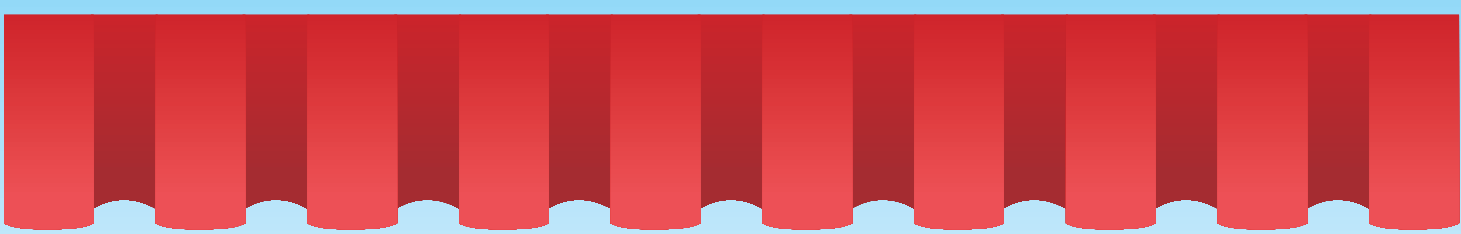

GRAND BUFFET & COMEDY SHOW

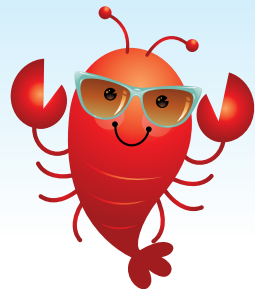

**Bass River Room
Friday, 6:30 PM
March 24, 2023**

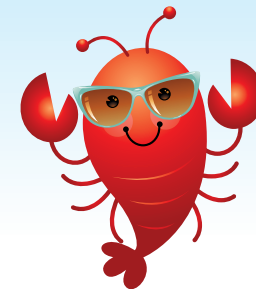

DO NOT miss your chance to win one of the cash prizes! *
DONT FORGET to bring your Pre-paid dinner tickets with you!

* - You must be present to win.

COME LAUGH WITH US!



KATHE FARRIS

Kathe Farris is a Boston-based stay-at-home mom, stand-up comedian, and snack cake enthusiast. She hit the comedy scene a little late in life with a different point of view and killer material. After becoming a Comic-in-Residence at The Comedy Studio and a finalist in the Boston Comedy Festival, she recently recorded her national debut with a Dry Bar Comedy Special.

With an eye for detail and an understated edge that speaks to grandparents and frat bros alike, Kathe performs regularly at everything from corporate events to a basement show full of hipsters (one time, went great). Her weekly show, Farris and Friends Comedy Hour, even became "The Boston Globe's Critics Choice." They didn't give her a plaque so she made one. She'll show you later.



BETHANY VAN DELFT

Bronx-born Bethany Van Delft moved to Boston as a tween with her Marxist Dutch dad, black Puerto Rican mother and siblings, where she quickly learned "zebra" didn't mean she was weird but cool. She went to Paris to model at "19", got kicked out, ended up in Milan eating gelato and speaking Spanglish with an Italian accent.

Her "hip & grounded, laid back delivery" has earned her the honor of performing at the prestigious Just for Laughs Festival in Montreal, as well as SF Sketchfest, All Jane Festival, and the 2 Dope Queens podcast.

Bethany is a regular performer and producer for Boston Comedy Festival and Women in Comedy Festival, her series at the Women in Comedy Festival, "38/7%" is a hit, and monthly show, Artisanal Comedy, has been named "one of the top indie nights to check out". Her hilariously cringeworthy storytelling show/podcast with co-producer Nick Chambers, "Starstruck: Close Encounters of the Awkward Kind," won Best Comedy Night in Boston from Improper Bostonian and in 2019, Bethany was named "Best Comic 2019" by Boston Magazine.



GARY PETERSEN

A rising performer, Petersen was named best comedian by Boston Magazine. He has opened for his favorites like Maria Bamford, Gary Gulman & Jake Johannsen while also writing on projects featured on Team Coco and Comedy Central.



2023 PROGRAM SEMINARS

Friday, March 24, 2023

Please be advised seminars can change and run anywhere from 45 minutes to an hour and a half and may run over. Thank you for your understanding.

Atlantic States Marine Fisheries Commission Public Hearing on Addendum XXVII

Friday 9:00 AM - 11:00 AM

Room: Centerville

Presented by:

Catlin Starks, ASMFC and Dan McKiernan, MADMF

(This has not been finalized yet)

Cooking Demo

Friday 10:45 AM

Room: Bass River

Come see and taste what the Resort and Conference Center's Master Chef will create for you this year. You can't miss this so get there early and get ready to be dazzled. Please check the Show Program for the final menu.

Alternative Bait, Technology Development, and Understanding Hypoxia: Collaborative Sea Grant American Lobster Research

Friday 11:30 AM - 1:00 PM

Room: Centerville

Presented by:

Jennie Rheuban (WHOI Sea Grant), Amalia Harrington (Maine Sea Grant), Rob Vincent (MIT Sea Grant), Erin Pelletier/George Maynard (GOMLF), Tracy Pugh (MADMF), and Malcolm Scully (WHOI)

The Sea Grant American Lobster Initiative, funded by the National Oceanic and Atmospheric Administration's National Sea Grant College Program, is addressing critical knowledge gaps about American lobster and its iconic fishery in a dynamic and changing environment. The initiative, which began in 2019, supports both scientific research and a regional Sea Grant extension program in the Northeast U.S.

Together, the research and extension components of this initiative will develop and share new knowledge and understanding with industry stakeholders and resource managers from Maine to New York. This session will feature four research projects supported either directly or indirectly by the Sea Grant ALI program that address issues that are directly relevant to the lobster industry. Projects highlighted will include: the development of alternative bait to address the bait shortage, understanding the causes of the hypoxia events in Cape Cod Bay, and providing lobstermen with new technology, sensors, and data imaging tools to navigate a changing environmental and regulatory landscape.

Offshore Wind: Current Status & Next Steps

Friday 2:00 PM - 3:00 PM

Room: Centerville

Presented by:

Zach Jylkka, Bureau of Ocean Energy Management (BOEM), Lisa Engler, MA Coastal Zone Management (CZM)

BOEM will summarize the current status of existing offshore wind leases in Southern New England, and will focus on the Gulf of Maine, covering research, planning for future commercial wind energy, and upcoming engagement opportunities. BOEM will seek feedback and questions from the audience on BOEM's wind energy process, fisheries data, and next steps.

CZM will give an overview of the Commonwealths renewable energy goals, review of offshore wind projects, coordination with other states, as well as public engagement opportunities with the ongoing MA Fisheries Working Group efforts.

Decompress in the Bait Shed

Friday 4:00 PM

Room: Centerville

Come listen to Brian Robbins, CFN's columnist invites you for a session of tunes and storytelling. Take a break, have some grins, and bring a tale of your own. This guy's from ... Maine?

Brian Who? Now pay attention here, folks: if you landed here looking for Brian Robbins the film actor/director/producer, it ain't me, babe, and wails away on the guitar, mandolin and bouzouki while bellowing, blowing on a harmonica, and stomping his foot, then you are in for a great time.

Saturday, March 25, 2023

The American Lobster Settlement Index: History, lessons & future of a long-term, cross-border collaboration

Saturday 9:00 AM - 10:00 AM

Room: Centerville

Presented by:

Rick Whale, Lobster Institute

Rick will give an update on how we're using the American Lobster Settlement Index as a forecasting tool for trends in the fishery, and to understand the causes and consequences of ups and downs in young-of-year lobster recruitment to coastal nurseries and their subsequent survival to the fishery, including climate change effects.

Craft Seminar – Make a Candy Bouquet

Saturday 10:00 AM - 12:00 PM

Room: Barnstable III

Presented by:

Pam Bartlett

Who needs a flower bouquet when you can make a delicious candy bouquet. Come have fun with Pam as she helps you build a delicious candy bouquet for that someone special in your life. Space is limited so you must sign up at the MLA Booth.

On-demand Gear Scoping Phase 2: What are the costs?

Saturday 10:15 AM - 11:15 AM

Room: Centerville

Presented by:

Noah Oppenheim

On-demand (ropeless) fishing gear would impact many aspects of commercial fishing, fishery manage-

ment, the ocean environment, and coastal communities. In late 2020, the Massachusetts Division of Marine Fisheries initiated a project to assess the issues of on-demand gear. The first phase of the project highlighted the operational, technical, legal/regulatory, and socioeconomic issues surrounding the gear, and a report was issued in April 2022 (available at www.bit.ly/ropeless-report). Phase 2 of the project attempts to answer a key question for the first time: what impact could the use of on-demand gear have on the profitability of Massachusetts lobster fisheries? To answer this question, a socioeconomic model was created, using Vessel Trip Report data and input from industry, to determine the trip-level impacts to revenue alongside other changes to fixed costs incurred by operators. This presentation will detail the process used to develop the model, explore some of its early findings, and discuss its implications.

Sleep & Stress at Sea (& Solutions!)

Saturday 11:30 AM - 12:30 PM

Room: Centerville

Presented by:

Mandy Roome, Northeast Center for Occupational Health and Safety;

Lucy Bischoff, Northeast Center for Occupational Health and Safety

Researchers at the Northeast Center for Occupational Health and Safety: Agriculture, Forestry and Fishing (NEC) have been working with commercial fishermen in Massachusetts (lobster & scallop), Oregon (crab) and Alaska (salmon) over the past three years to understand learn more about sleep, stress, and health at sea. Deaths of commercial lobstermen accounted for the highest number of occupational fatalities in East Coast fisheries from 2010-2014, according to the National Institute of Occupational Safety and Health. Come join our discussion about what we have learned about health and safety at sea.

The NEC is funded through the Centers for Disease Control to address prominent occupational safety and health hazards in agricultural, forestry and fishing communities

throughout the Northeast. In addition to conducting research and developing safety programs, the Center offers safety training, health screening and counseling services to agricultural, forestry and fisheries workers.

MA Division of Marine Fisheries and MA Environmental Police Roundtable

Saturday 1:30 PM - 2:30 PM

Room: Centerville

Presented by:

MA Division of Marine Fisheries and MA Environmental Police

The Massachusetts Division of Marine Fisheries (DMF) is responsible for the conservation of marine fisheries resources. This includes managing both recreational and commercial harvesting of saltwater finfish, shellfish, and crustaceans like lobster and crab. The DMF oversees policy which promotes sustainability while balancing the requirements of a complex coastal fishing industry. State officials will be on hand to present new information on lobster stock status, fishery trends, whales, and discuss other issues of concern to the industry.

The Massachusetts Environmental Police protect the environment and natural resources through enforcement, education, and public outreach. The “U.S. marine resource laws exist to ensure sustainable fish populations; protect threatened marine species and the habitats they live in and to ensure these resources are around for future generations to enjoy. When people cheat and willfully violate fishery management regulations it puts those who comply with the rules at a significant disadvantage.

Lobstermen: Responsible Stewards of Marine Resources

Saturday 3:00 PM

Room: Centerville

Presented by:

David Bethoney, PhD, Executive Director, Commercial Fisheries Research Foundation and Michael Long, Research Biologist

Since 2004, the Commercial Fisheries Research Foundation (CFRF) has focused

on working collaboratively to build relationships among scientists, managers, and members of the fishing industry to solve problems facing fisheries resources and fishing communities. The CFRF Lobster and Jonah Crab Research Fleet is an excellent example of the willingness and dedication of lobstermen to participate in collaborative research that contributes to the sustainable management of marine resources. This seminar will highlight the impactful work of these Research Fleet participants. Since 2013, commercial fishermen have been collecting biological data on American lobsters in Southern New England, Georges Bank and the Gulf of Maine. Many of the lobsters sampled are from offshore areas and times of year that are not traditionally sampled by federal surveys and has become essential data for the lobster stock assessment. This nine-year time series has also allowed for work that has extended the impact of the Research Fleet. The data is currently being used to: 1) investigate spatial patterns in the lobster population, 2) investigate lobster shell disease, 3) improve Jonah crab management, 4) link temperature with biological data and 5) evaluate lobster and Jonah crab demographics in the Northeast Canyons and Seamounts Marine National Monument area, and. All of these projects give scientists and stakeholders a better understanding of the lobster and Jonah crab resource and further contribute to sustainable management.

After the general overview, this seminar will shift focus to specifically highlight work done to characterize American lobster and Jonah crab fishery resources within the Northeast Canyons and Seamounts Marine National Monument and adjacent areas through data provided by commercial fishing vessels as part of CFRF’s Lobster and Jonah Crab Fleet. Comparisons of Monument data and adjacent areas revealed unique catch characteristics for many biological parameters collected; however, differences were seen for lobster and Jonah crab. This study provides the baseline conditions to enable a Before-After-Control-Impact approach to assess the effectiveness of then MPA if the lobster and crab fishery is eventually closed within the Monument.



MLA AWARDS / GRAND BANQUET

MLA GRAND BANQUET & MLA AWARDS CEREMONY



**Bass River Room
Saturday Evening
6:30 PM
March 24, 2023**



DONT FORGET to bring your Pre-paid dinner tickets with you!

FREE DRAWING



FIVE MERRY WEEKEND GETAWAYS

at the
Resort and Conference Center at Hyannis &

CASH PRIZES

all to be drawn at the Banquet. You must be present to win.



MASSACHUSETTS LOBSTERMEN'S ASSOCIATION FREE MEMBERS RAFFLE & GIFT



FOR DUES PAYING MEMBERS!

- As a member, you have **5 CHANCES** of winning **\$100 CASH**.
- **FREE** member gift.
- You do not have to be present to win. We will notify you after the show.
- Not a member yet? Sign up today and fill out your membership raffle ticket.



SUNDAY MORNING RAFFLE

Rise and Shine for the MLA's Attendees Raffle!
After your coffee make your way down to the Exhibit Hall to pick up your ticket for a chance to win **CASH PRIZES**.

Tickets will be given out at the MLA booth on Sunday between **8:30 AM & 9:30 AM only** and drawn at **10:00 AM**.

YOU MUST BE PRESENT TO WIN



SUNDAY RAFFLE / MEMBERS GIFT



LIST OF 2023 EXHIBITORS

<i>Company Name</i>	<i>Types of Items on Display</i>
Athearn Marine Agency Inc.	Commercial Vessel & Permit Brokerage
Atty. Sam Blatchley	Maritime Lawyer
Avangrid	Offshore Wind Developer
Bait Claw	Bait Loading Claw
Bell Power Systems	John Deere Marine Engines
Boat Command VMS	Vessel Monitoring Systems
Brooks Trap Mill	Lobster Traps & Marine Supplies
Chris Electronics	Marine Electronics
Com. Fisheries Research Foundation	Collaborative Research
Commercial Fisheries News	Fisheries Newspaper
Cummins Sales & Service	Cummins Diesel Engines
Deckhand Electronic Logbook	Electronic Logbooks
DuraBrite Inc.	High Output LED Lights
Equinor Wind U.S.	Offshore Wind Developer
Fishery Friendly Climate Action	Climate Action
Fishing Partnership Support Service	Health Services & Safety Training
Friendship Trap Co	Lobster Traps & Supplies
Gulf of Maine Lobster Foundation	Lobster Research
Hercules SLR US Inc.	Marine Supply & Safety
Ketcham Traps	Lobster Traps & Supplies
Lobster Institute	Lobster Research
Local Colors Gallery	Art Prints of Marine Life
MA Division of Marine Fisheries	Fisheries Management
MA Environmental Police	Law Enforcement
MA Lobstermen's Association	Commercial Fishing Organization
Mack Boring & Parts Co	Diesel Engines & Parts
Mayflower Wind	Offshore Wind Developer
Milton CAT	Marine Engine
MLA Fishermen Services	Commercial Marine Insurance
N.E. Center of Occupational Safety	Commercial Fishing Safety
Navroc Marine Electronics	Marine Electronics
Net Your Problem LLC	Fishing Gear Recycling Service
New England Marine Engineering	Marine Industrial Equipment
New England Propeller	Boat Propellers & Accessories
NOAA NE Observer Program	Fishery Observer Program
NOAA Greater Atlantic Regional	Information and Outreach Material
North Atlantic Power Products	Twin Disc Marine Transmissions
Orsted US	Offshore Wind Developer
Patsy Kane Nautical	Nautical Jewelry
Power Products	Volvo Penta Engines & Parts
R.A. Mitchell	John Deere Engine
Responsible Offshore Development Alliance	Offshore Wind Commercial Fishing Organization
Riverdale Mills	Aquamesh Marine Wire
Sea Grant	Create and Maintain a Healthy Coastal Environment and Economy
Succorfish Limited	Vessel Monitoring Systems
Superior Lobster	Lobster Dealer
Three Lantern Marine	Marine, Fishing Supplies, Brooks Trap Annex
U.S. Coast Guard	Fishing Vessel Safety
Vineyard Wind	Offshore Wind Developer
Woods Hole Group	International Environmental, Scientific, & Engineering

WE DELIVER FRESH LOBSTER BAIT

INCLUDING:

HERRING

POGIES

MACKEREL

RED FISH

SKINS

BLUEFISH

CHUM

SALMON
HEADS



FRESH, SALTED, AND QUICK FROZEN BAIT

Barrel Head Bait

WE SELL SALT!

For More Information:

To Place An Order:

Mark Flight

mark@barrelheadbait.com

The Bait Line:

857-200-2129

Or Fax:

617-561-8471





MARINE • FISHING GEAR • SAFETY

44 South Street, New Bedford, MA 02740
 Phone: 508-993-0010 Fax: 508-993-9005
Securing – Lifting - Rigging
 82 MacArthur Dr. New Bedford, MA 02740
 Phone: 508-992-9519 Fax: 508-992-9419

JohnReardon@Hercules-SLR-US.com

USCG Safety Inspection Station #327

Commercial Fishing-Marine Safety-Rigging

- ❖ Marine Hardware
- ❖ Cotesi - Netting, Leaded/Sink Rope
- ❖ Stormline & Climate Technical-Foul Weather Gear
- ❖ Buoys & Floats
- ❖ Lobster Bands
- ❖ PFD's, Vests, Float Coats
- ❖ Fish Totes
- ❖ Insulated Tubs
- ❖ Cordage & Twine
- ❖ Mooring Equipment
- ❖ Boarding Ladders
- ❖ Polysteel Rope- Esterpro Sinking, Hydropro
- ❖ Leadline
- ❖ Wire Rope - FC Galv, IWRC, Dyform
- ❖ HiFlyers 12', 14' & 15' XHD
- ❖ Golf & Batting Cage Netting



Inflatable PFD's



Life Raft Sales

- ❖ Revere
- ❖ Elliot
- ❖ Survitec
- ❖ Switlik

All brands accepted for service



ACR Electronics
 Sales & Service
 for your E.P.I.R.B.



Fenders & Buoys-All Colors



Boots from Honeywell Safety

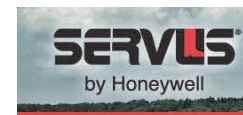

On-Board Vessel Inspections & Safety Drills

Call our USCG Certified Drill Conductors:

Rodney Avila 508-889-0401

Ted Williams 508-264-5779



Imperial
 Survival Suits
 Sales & Annual
 Inspections
 Done in house



Encore Hartco Tools & Clips
Stanley Spenax Tools & C-Rings
Wematic Tools & D-Rings
Simonds Pneumatic Wire Cutters
Spotnail Staplers & Staples



Complete Parts Inventory
Tool Repair Service

(781) 826-2522
Fax (781) 826 5252
www.fisherairfasteners.com
chris@fisherairfasteners.com

OVER 20 YEARS EXPERIENCE ~ ALL MATERIALS & SIZES

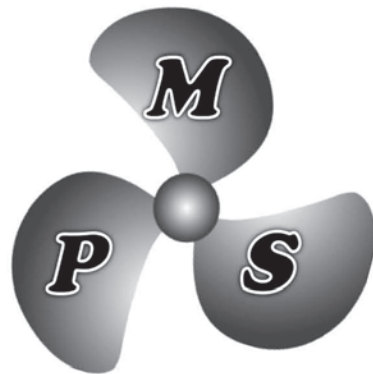

MARINE

PROPELLER SERVICE

FOR FAST SERVICE
CALL MIKE @
508.979.8000

REPAIRS &
RECONDITIONING
(Fast & Fully Insured)

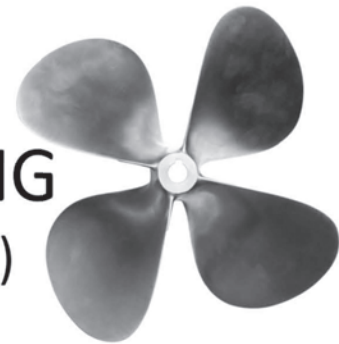

marine.propeller128@gmail.com

THE MOST RELIABLE PROPELLER SERVICE COMPANY ON THE SOUTHCOAST

74 MAIN STREET FAIRHAVEN MA 02719 508.979.8000 FAX 774.206.6449



*Atlantic States Marine
Fisheries Commission*

NEWS RELEASE

American Lobster Draft Addendum XXVII Approved for Public Comment Addendum Considers Measures to Increase Protection of Spawning Stock Biomass of the Gulf of Maine/ Georges Bank Stock

Arlington, VA – The Commission’s American Lobster Management Board approved Draft Addendum XXVII to Amendment 3 to the Interstate Fishery Management Plan for American Lobster for public comment. The Draft Addendum considers implementing management measures – specifically gauge and escape vent sizes – to provide additional protection to the spawning stock biomass (SSB) in the Gulf of Maine/Georges Bank (GOM/GBK) stock. The Draft Addendum also considers immediate action upon final approval to standardize some management measures within and across the Lobster Conservation Management Areas (LCMAs) that include the GOM/GBK stock.

The Board initiated the Addendum as a proactive measure to improve the resiliency of the GOM/GBK stock. Since the early 2000s, landings in the GOM/GBK stock have exponentially increased. In Maine alone, landings have increased from 57 million pounds in 2000 to a record

high of 132.6 million pounds in 2016. Maine landings have declined slightly but were still high at 97.9 million and 108.9 million in 2020 and 2021, respectively. However, since 2012, lobster settlement surveys throughout the GOM have generally been below the time series averages in all areas. These surveys, which measure trends in the abundance of juvenile lobsters, can be used to track populations and potentially forecast future landings. Persistent lower densities of settlement could foreshadow decline in recruitment and landings. In the most recent years of the time series, declines in other recruitment indices have also been observed.

Given the economic importance of the lobster fishery to many coastal communities in New England, especially in Maine, potential reductions in landings could have vast socioeconomic impacts. In addition, the 2015 Stock Assessment combined the GOM and GBK stocks into a single biological unit due to evidence of migration between the two regions.

As a result, there are now varying management measures within a single biological stock. In response to these two issues, Draft Addendum XXVII considers the standardization of management measures across LCMAs. The purpose of considering more consistency in measures is to resolve discrepancies between the regulations for state and federal permit-holders, to provide a consistent conservation strategy, and simplify enforcement across management areas and interstate commerce.

Draft Addendum XXVII considers two approaches for implementing changes to gauge and escape vent sizes to enhance protection of the GOM/GBK spawning stock. One approach would establish a trigger mechanism whereby pre-determined management changes would be implemented upon reaching a defined trigger level based on observed changes in recruitment abundance indices. The second approach would establish a schedule for implementing changes to the gauge and escape vent sizes.

The proposed measures include an increase to the minimum gauge size and escape vent sizes in LCMA 1 (Gulf of Maine) and decreases to the maximum gauge size in LCMA 3 (off-shore federal waters) and Outer Cape Cod. The proposed gauge and escape vent sizes are expected to increase the proportion of the population that is able to reproduce before being harvested by the fishery, and to enhance stock resiliency by protecting larger lobsters of both sexes.

The Draft Addendum will be posted to the website next week at <http://www.asmfc.org/about-us/public-input>. A subsequent press release will provide the details on the public hearing schedule and how to submit written comments. The Board will meet to review submitted comment and consider final action on the addendum in May 2023 at the Commission’s Spring Meeting in Arlington, VA. For more information, please contact Caitlin Starks, Senior Fishery Management Plan Coordinator, at cstarks@asmfc.org or 703.842.0740.

The Atlantic States Marine Fisheries Commission was formed by the 15 Atlantic coastal states in 1942 for the promotion and protection of coastal fishery resources. The Commission serves as a deliberative body of the Atlantic coastal states, coordinating the conservation and management of nearshore fishery resources, including marine, shell and diadromous species.

1050 N. Highland Street • Suite 200A-N • Arlington, VA 22201
703.842.0740 (phone) www.asmfc.org

January Store Special



Store Hours
Mon – Fri:
8am – 4pm

Seamaster
Buoys
8 X 15"

\$13 ea.

While Supplies Last!

111 Myrtle Street
New Bedford, MA 02740
508.997.4787



www.ketchamsupply.com
info@ketchamsupply.com
f @ketchamtraps



Rose Marine

Gloucester, MASS www.rosesmarine.com

Aqualoy Stainless
Propeller Shafts & Accessories



Largest stock of **Aqualoy** Prop
Shafting on the East Coast.
Emergency turn-around time available.



Call or e-mail Peter Tetrault
for a price.
peter.tetrault@rosesoil.net



877-283-3334



ROTZLER
TITAN TI

Hydraulic Hoisting Winch

Four Models from
2,850lb – 12,300 lb Pull Capacity



Quality Oil Coolers
Made in the U.S.A



- All Seamless Tubing
- High pressure available
- 90/10 copper-nickel

Mufflers and Exhaust Components



Stainless Steel Mufflers
2" – 8" inlet size in stock



BelMar
Industries

Anchor Flush Mount Hatches

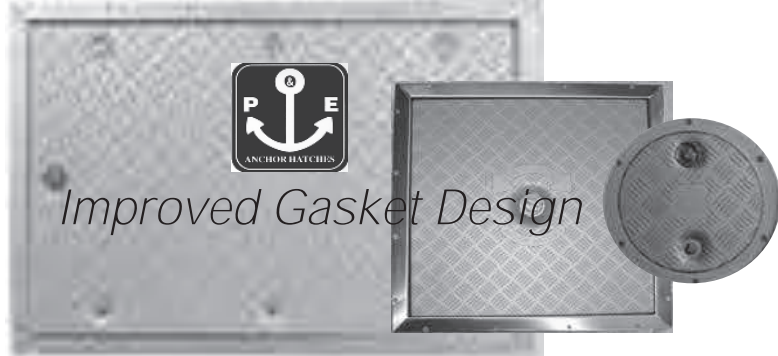

Improved Gasket Design



KOBELT

Controls



Cablecraft
PUSH-PULL CONTROLS

*Ask for the
Green Marine*

MLA SCHOLARSHIP APPLICATION

MASSACHUSETTS LOBSTERMEN'S ASSOCIATION, INC. SCHOLARSHIP AWARD APPLICATION 2023 *IN MEMORY OF ROBERT A. WHEELER*

This application should contain accurate and detailed information and be accompanied by a copy of your official high school transcript that is signed and sealed.

Name: _____

Home Address _____

City/Town: _____ State _____ Zip _____

Father, Mother and/or Guardian's Name: _____

Occupation _____

Are you a current member of the Massachusetts Lobstermen's Association? [] Yes [] No

Are both parents living? [] Yes [] No

Number and ages of siblings living at home: _____

Do you have anyone financially dependent upon you? [] Yes [] No

If yes, please explain: _____

How much financial aid is expected in your first year of college/trade school: _____

Name of High School and year of graduation: _____

Name of college or trade school you expect to enter: _____

Have you been accepted: _____ What is your anticipated tuition: _____

Have you received any other scholarships - If yes, state amount(s): _____

What business or profession do you expect to prepare for: _____

What extra-curricular activities have you participated in: _____

REFERENCES: **Please enclose any letters of recommendation** and **at least two** from the following choices: School Principal, Guidance Counselor, Instructor in your major, Pastor or Minister.

Please write a short paragraph explaining why you are interested in your field of endeavor:

Scholarships are awarded at the discretion of the scholarship committee. All decisions are final.

SIGNATURE: _____ DATE: _____

-- THIS APPLICATION MUST BE RETURNED BY MAY 1st --

Mail or drop off applications to:
Massachusetts Lobstermen's Association Scholarship Committee, 8 Otis Place, Scituate, MA 02066

Make cleanup
easy and fast.

Blast Away!

Onboard Pressure Washers
5.6 GPM @ 3,500 PSI

Our pressure washers
come with everything you
need, including 50' hose and
wand with turbo nozzle.



Belt Driven

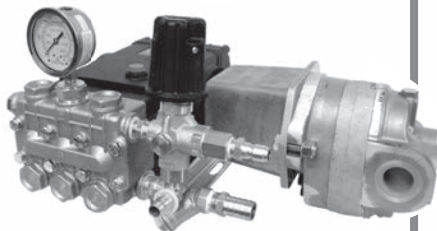

Hydraulic

Salt or Fresh Water

Coastal Hydraulics, Inc.

603-474-1914 • sales@coastalhyd.com
www.coastalhyd.com
28 Route 286, Seabrook, NH



THE *Specialists*
FROM BUOY TO TRAP

Built the Best, Built to Last,
Built Your Way.

PROVEN PERFORMERS! Rockbottom Runners



THEY MAKE
THE BEST
CRAB
TRAPS
TOO!!

Our precision formulation
and process has been
refined over the years
to provide the optimum
balance of strength and
flexibility... – and the
wise test shows it

Over **20 YEARS**
of fishing;

Well over **HALF**
A MILLION sold



Could you do this with
any other concrete runner?

lite load

SOLID STEEL CORE
- TOUGH POLYMER
COATING



Over
6 YEARS
of fishing.

Over a **QUARTER**
MILLION sold

GORILLA WOOD
RUNNERS

OCEAN-TESTED for years...
aircraft carrier decking and
pilings in the marine borer
intense Panama
Canal Zone.



The toughest species
of junglewood we've found
... and the only kind we sell.

We are constantly listening to our customers:
Your feedback + continuous improvement
= proven reliability

Here to serve you!

Jerry Wadsworth (207) 542-0842 jerryw@friendshiptrap.com

Jimmy Emerson (207) 483-6555 jemerson@friendshiptrap.com

Mike Wadsworth (207) 542-0841 mikew@friendshiptrap.com

Friendship Office: (800) 451-1200; (207) 354-2545

Columbia Falls Office: (800) 339-6558

Visit our website: www.friendshiptrap.com



Steve's Rope Splicing

Custom Rope Splices

BUOY LINE MARKING INSERTS

Massachusetts Vertical Line Solid Top Mark

NOAA & DMF Approved

20" Loop for easy attachment to buoy end

Removable Green Federal Marking

\$8



1200' Spools of
Red & Green
3/8" Poly

\$145

978-879-9737

StevesRopeSplicing@Gmail.Com

Gloucester, MA



NEW ENGLAND PROPELLER, INC.

Distributor of Michigan Propellers

Inboard • Outboard

Next Generation 3D Computerized Propeller Analyzer
Computerized Dynamic Balancing



Marine Fuel Tanks

Custom Fabricated & Tested to U.S.C.G Specifications
By Capeway Welding

- Marine Propeller Sales & Repairs - ***4000 Props in Stock***
 - Sierra Engine Parts for All Outboards & IOs
 - CDI Electronics • Camp & Godfrey Zincs
 - NGK Spark Plugs
 - Duramax Cutless Bearings • Spurs Line Cutters
 - PSS Dripless Shaft Seals
 - Buck Algonquin - Struts, Rudders & Stuffing Boxes
 - S/S Shafting • Drive Savers • Globe Impellers



9 Apollo Eleven Rd., Plymouth, MA 02360
Tel: 508-747-6666 800-635-9504 - neprop.com



Legal Defense Fund Updates

The Massachusetts Lobstermen's Association (MLA) Legal Defense Fund (LDF) needs your support now more than ever. This dedicated fund is for the purpose of defending the Massachusetts commercial lobster fishermen from legal and fisheries management actions that could seriously impact our commercial lobstermen's ability to conduct their businesses and earn a living.

Currently, the MLA is actively engaged in three separate lawsuits that could have negative impacts on the commercial lobster industry and is working with multiple lawyers in Washington D.C. and here in the Commonwealth to fight for you and your industry.

UPDATE JANUARY 30, 2023 — Omnibus Bill:

The recent Omnibus Bill passed by Congress and signed by President Biden contained crucial language inserted by Senate Majority Leader Chuck Schumer (D-N.Y.) and Senator Patrick Leahy (D-Vt.) for the future of the lobster industry. While our lawyers are still parsing through

the language to prepare a detailed summary of its effects, the important language seems to provide that the lobster industry can continue to operate using its current technologies and techniques through December 31, 2028.

The relevant language from the Omnibus Bill is below:

DIVISION JJ—NORTH ATLANTIC RIGHT WHALES TITLE I—NORTH ATLANTIC RIGHT WHALES AND REGULATIONS SEC. 101. NORTH ATLANTIC RIGHT WHALES AND REGULATIONS. (a) IN GENERAL.—Notwithstanding any other provision of law except as provided in subsection (b), for the period beginning on the date of enactment of this Act and ending on December 31, 2028, the Final Rule amending the regulations implementing the Atlantic Large Whale Take Reduction Plan (86 Fed. Reg. 51970) shall be deemed sufficient to ensure that the continued Federal and State authorizations of the American lobster and Jonah crab fisheries are in full compliance with the Marine Mammal Protection Act of

1972 (16 U.S.C. 1361 et 20 seq.) and the Endangered Species Act of 1973 (16 U.S.C. 21 1531 et seq.). The National Marine Fisheries Service shall— (1) throughout the period described in the preceding sentence, in consultation with affected States and fishing industry participants, promote the innovation and adoption of gear technologies in the fisheries described in the preceding sentence, in order to implement additional whale protection measures by December 31, 2028; (2) promulgate new regulations for the American lobster and Jonah crab fisheries consistent with the Marine Mammal Protection Act of 1972 (16 U.S.C. 1361 et seq.) and the Endangered Species Act of 1973 (16 U.S.C. 1531 et seq.) that take effect by December 31, 2028, utilizing existing and innovative gear technologies, as appropriate; and (3) in consultation with affected States, submit an annual report to Congress on the status of North Atlantic Right Whales, the actions taken and plans to implement measures expected to not exceed Potential Biological Removal by December 31, 2028, the

LDF UPDATES, Page 36

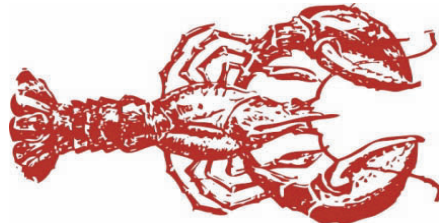

**“Specializing in the sale & delivery of
LOBSTER BAIT
for over 30 years”**

FRESH FROZEN AND SALTED BAIT AVAILABLE

**SKATES ~ HERRING ~ POGIES ~ HADDOCK ~ COD FISH ~ POLLOCK
FLAT FISH ~ FISH SKINS ~ RED FISH ~ DOG FISH HEADS ~ SALMON**



**C & P BAIT
33 Wright St
New Bedford, MA 02740**

**Contact:
Danny Costa 508-951-9818
Carlos Pereira 508-951-9819**

LDF Updates

FROM PAGE 35

amount of serious injury and mortality by fishery and country, and the proportion of the American 19 lobster and Jonah crab fisheries that have transitioned to innovative gear technologies that reduce harm to the North Atlantic Right Whale. (b) EXCEPTION.—The provisions of subsection (a) shall not apply to an existing emergency rule, or any action taken to extend or make final an emergency rule that is in place on the date of enactment of this Act, affecting lobster and Jonah crab.

This is a big reason to celebrate! However, we do anticipate a flurry of litigation by environmental groups to try to weaken this language. This might also affect the current litigation summarized below. Finally, it is not clear how NMFS will interpret this language but we are fully prepared to continue the fight to protect the lobster industry and ensure that our cutting-edge efforts and sacrifices to protect the Right Whale earn the recognition they deserve.

UPDATE JANUARY 30, 2023 — (Washington D.C.) Case 1:18-cv-00112-JEB - CENTER FOR BIOLOGICAL DIVERSITY et al v. ROSS et al.

There have been no notable developments in this matter since the most recent update, although it is possible, and indeed even likely, that NMFS will move to dismiss and vacate the Remedy Order in this matter in light of the Omnibus Bill.

UPDATE JANUARY 30, 2023 — (D.C.) Maine Lobstermen's Association, et al. v. NFMS

ORDER GRANTING SUMMARY JUDGMENT - Judge Boasberg has issued his summary judgment order in MLA v. NMFS ruling against the Maine Lobstermen's Association (and us) on every single ground we raised challenging the 2021 BiOp.

As we have tracked in our last few updates, we appealed Judge Boasberg's order to the D.C. Circuit and the matter has now been fully briefed.

Our Reply Brief was due on January 10, 2023 and in that Brief we pointed out that NMFS was being hypocritical by now taking the position that it never took "worst-case scenario" approaches despite explicitly stating that it was doing so.

Despite the appeal being fully briefed and the time for motions having passed, NMFS recently brought a motion for leave to file a motion to dismiss the appeal, and a motion to dismiss. In its motion to dismiss, NMFS is now claiming that it will not be issuing any new regulations on the current Biological Opinion, and that it will have to issue new regulations only on new technology

later. Thus, NMFS argues, the appeal is moot and should be dismissed.

We have aggressively opposed this move, first objecting to the motion for leave to file a motion to dismiss, and we intend to file an aggressive brief against NMFS's motion to dismiss. We believe NMFS is intentionally and deliberately misleading the Court as to the effect of the Omnibus Bill, as the Omnibus Bill requires NMFS to issue new regulations based on existing and new technologies. Also, we will assert that the underlying issue with the Biological Opinion, the reliance on worst-case scenarios, is capable of being repeated (an exception to a mootness argument) because NMFS will use worst-case scenarios again. With these arguments, we believe the D.C. Circuit has good reason to not dismiss the appeal and to hear the arguments.

The commercial lobstermen's businesses are at stake as well as the thousands of jobs and shore side businesses that depend upon the continued success of the commercial lobster industry. The commercial lobstermen in Massachusetts are NOT to the problem and have done everything asked of them by National Marine Fisheries Service and have been working under the strictest conservation rules for the right whales anywhere in the world since 2014. Yet here we are, still fighting these lawsuits to keep the Massachusetts commercial lobstermen fishing.

The Massachusetts Lobstermen's Association has been actively involved in these lawsuits since 2018 and we need your generous support today to continue our fight to keep the commercial lobstermen fishing. As we all know, any legal action costs lots of money and over the last 5 years the Massachusetts Lobstermen's Association Legal Defense Fund has spent over \$300,000 fighting these legal battles. These are real threats to the historic and iconic commercial lobster industry and we are doing everything to keep the Massachusetts commercial lobstermen fishing.

WHERE TO MAKE DONATIONS

Any contribution you can afford to make to the Legal Defense Fund is greatly appreciated.

Donate by mail:

MLA LDF
8 Otis Place
Scituate, MA 02066

Donate online:

www.lobstermen.com

– In the Members section, select Dues/Donate.



DONATE TODAY!

to the Massachusetts Lobstermen's Association

LEGAL DEFENSE FUND

FEBRUARY 2023 SUPPORTERS

Matt Brennan

Dana Campbell

Al Eagles

Geordie King

Eric Lorentzen

Michael Morin

Kevin O'Maley

Therese Sauvageau

Sarah Young

THANK YOU FOR YOUR CONTINUED SUPPORT!



Donate to the MLA Legal Defense Fund to
“Band the Bite” TODAY!

Help us fill the lobster crate and help relieve
the **“PINCH”** of defending commercial lobstermen!

Let's fill the lobster crate TODAY!

Every \$25 dollars donated puts another lobster in the lobster crate!!

There are several ways to make a donation

MLA website: www.lobstermen.com Legal Defense Fund Donation

Paypal: Legal Defense Fund Donation

Mail or drop off a check:

MLA, 8 Otis Place, Scituate, MA 02066

Call the MLA : 781-545-6984 xt2

Use your camera on your phone to Scan the QR Code

***THANK YOU for YOUR
CONTINUED SUPPORT!***



CAT[®] Marine Power – C18

Available for new boat installations and repowers.



Ask us about our Customer Value Agreements (CVA)

C18 RATINGS

470/600@1800rpm A Rating

670/715@1800-2100rpm B/C rating

803@2100rpm D Rating

1015/1150@2300rpm - T4 Exempt ratings for light commercial

For Marine Engine Sales, contact Nick Fawle, Marine Market Manager.
603-484-5248 Nick_Fawle@miltoncat.com

AUTHORIZED MARINE DEALERS

Billings Diesel & Marine Service
Stonington, ME

Dennis' Welding & Marine
Beals, ME

Front Street Shipyard
Belfast, ME

Lyman Morse at Wafarer Marine Corporation
Camden, ME

Journey's End
Rockland, ME

Fairhaven Shipyard & Marina, Inc.
Fairhaven, MA

Guy Crudele Repair
Gloucester, MA

Sacchetti Marine and Industrial, LLC
Plymouth, MA

Windward Power Systems
Fairhaven, MA

DePaul Diesel Services, Inc.
Portsmouth, RI

Hinckley Yacht Service
Portsmouth, RI

Rhode Island Engine Company, Inc.
Narragansett, RI

Milton 

miltoncat.com

Massachusetts Lobstermen's Association
8 Otis Place
Scituate, MA 02066

PRSR STD
U.S. POSTAGE
PAID
Permit 137
New England Newspapers, Inc.



**Stock and Custom-Built Traps
Lobster and Specialty Traps
Aquaculture Supplies
Huge Inventory of Commercial
Fishing Supplies
Four Locations in Maine**



**BROOKSTRAPMILL.COM
(800) 426-4526**