



**MASSACHUSETTS  
LOBSTERMEN'S  
ASSOCIATION**

A LEADING Commercial Fishing Industry Association in New England

**MASSACHUSETTS  
LOBSTERMEN'S  
ASSOCIATION**



**JOIN TODAY and  
show your support**

JANUARY 2023 NEWSPAPER • WWW.LOBSTERMEN.COM

# Massachusetts Lobstermen's Association Celebrates 60 years of Service and Leadership!

Congratulations, to the Massachusetts Lobstermen's Association (MLA) on their 60 years of service, dedication, and leadership on behalf of the commercial lobster industry.

The Massachusetts Lobstermen's Association was established in 1963 by the fishermen, for the fishermen, and is presently one of the leading commercial lobster industry associations in New England. On behalf of the ~1,800 members, the MLA works to maintain both the industry and the resource. The MLA strives to be proactive on issues affecting the lobster industry and is active in the management process at both the state and federal levels.



---

***MISSION STATEMENT: The Massachusetts Lobstermen's Association is a member-driven organization that accepts and supports the interdependence of species conservation and the members' collective economic interests***

---

The MLA communicates with its members through a monthly newspaper, weekly email, social media, and attendance at industry related meetings. For the past 60 years, the MLA has become a trustworthy voice for the commercial lobster industry on important issues and is looked to by both

the commercial fishing industry and the fisheries managers alike. The MLA would not be the unwavering and time-tested organization without the thousands of members, Officers, Executive Committee members, Delegates, and Executive Directors over the last 60 years steering us in the right direction.

Here's to many more MLA years of celebrations for all of you that have helped the MLA remain a steadfast leader as a voice for the commercial lobster industry. As always, the MLA remains here for you!



SERIOUS ABOUT SAFETY

LRSE.COM | 401-816-5400

590 FISH RD, TIVERTON, RI 02878  
 181 OLD COLONY AVE, UNIT A, BOSTON, MA 02127  
 55 STATE ST, NARRAGANSETT, RI 02882



SALES • SERVICE • TRAINING • RENTAL • OUTFITTING • PICKUP + DELIVERY

### Safety Equipment Servicing

Life Raft + Survival Equipment has been selling and servicing all major brands of Life Rafts, EPIRBs/PLBs, Life Jackets, Immersion Suits, and Man Overboard Equipment since 1983.

We offer pickup and delivery to over 20 locations throughout the Northeast.

CALL FOR GREAT PRICING.

### North East Safety Training

NEST, a division of LRSE, offers hands-on Basic, Advanced, and Customized Safety Training Courses, Monthly Drill Conducting, First Aid/CPR/AED Courses and Vessel Inspections.

VISIT OUR WEBSITE TO LEARN MORE.

-  LIFE RAFTS
-  EPIRBs + PLBS
-  LIFE JACKETS
-  IMMERSION SUITS
-  MAN OVERBOARD
-  PICKUP + DELIVERY

### COMMERCIAL LIFE RAFTS

Elliot, Zodiac, Crewsaver, Revere, Viking



### FIBRELIGHT LADDERS

Man Overboard Recovery Cradle, Self Recovery Ladder



### IMMERSION SUITS

Imperial



### EPIRBs

ACR V4



### FIRETKO®

Fire Suppression Tool



### LIFE JACKETS

Mustang



# MLA Sponsors

The following companies are proud supporting MLA members. We encourage our members to patronize them. If your company is not listed and you would like it to be, contact Tracey Abboud at 781-545-6984, ext. 2

**ALIVE & KICKING LOBSTER**  
LOUIS MASTRANGELO  
CAMBRIDGE, MA  
617.876.0451

**BAR HARBOR LOBSTER**  
JEFF HAZELL  
ORLANDO, FL  
407.851.4001

**BOSTON LOBSTER**  
NEIL ZARELLA  
617.464.1500  
bostonlobstercompany.com

**BOSTON SWORD & TUNA**  
STEPHEN SCOLA  
BOSTON, MA  
617.946.9850

**BROOKS TRAP MILL**  
STEPHEN BROOKS  
THOMASTON, ME  
207.354.8763  
stephen@brookstrapmill.com

**CAPE ANN MARINE**  
SALES & SERVICE  
978.283.0806  
CapeAnnMarina.com

**C-TRAP**  
MATT BORGES  
MATTAPOISETT, MA  
508.758.2740

**CAPE SEAFOODS**  
**BAIT DEALER**  
GERRY O'NEIL  
GLOUCESTER, MA  
978.479.4642

**CAPE FISHERMEN SUPPLY**  
DAVE LIBBY  
CHATHAM, MA  
508.945.3501

**CAPE TIP SEAFOODS**  
CHRIS KING  
PROVINCETOWN/ORLEANS  
508.487.0259 | 508.225.7221

**CAPTAIN MARDEN'S**  
**SEAFOODS**  
KIM MARDEN  
WELLESLEY, MA  
781.329.7007 | 781.329.0792  
captainmardens.com

**CHERRY ST. FISH MARKET**  
DARRYL PARKER  
DANVERS, MA  
978.777.3449

**CHRIS ELECTRONICS CORP.**  
FAIRHAVEN, MA  
508.994.8257

**COASTAL HYDRAULICS**  
RICH TUCKER  
SEABROOK, NH  
603.474.1914  
coastalhyd.com  
sales@coastalhyd.com

**COHASSET LOBSTER**  
**POUND**  
TOMMY ALIOTO  
COHASSET, MA  
781.383.1551

**EAST COAST SEAFOOD**  
SPIROS TOURKAKIS  
LYNN, MA  
781.593.1737

**ECKLAND & BLANDO**  
SAM BLATCHLEY  
BOSTON, MA 02110  
617.217.6936  
www.ecklandblando.com

**ELECTRA-DYNE CO INC.**  
JUDY MACCAFERRI  
PLYMOUTH, MA  
508.746.3270

**FARM CREDIT EAST**  
MIDDLEBORO, MA  
508.946.4455

**FISHER AIR FASTENERS**  
ED & CHRIS FISHER  
PEMBROKE, MA  
781.826.2522

**FISHERMEN SERVICES**  
DONNA CHEPREN  
781.545.5073 Ext. 16  
fishermenservices.com

**FLEET PROPELLER**  
**SERVICE**  
MIKE VALM  
FAIRHAVEN, MA  
508.979.8000

**FRIENDSHIP TRAP CO.**  
JERRY WADSWORTH  
FRIENDSHIP, ME  
800.451.1200

**HAMILTON MARINE INC.**  
56 US ROUTE 1 BYPASS  
KITTERY, ME 03904  
207.439.1133  
hamiltonmarine.com

**HARBOR FUELS**  
info@harborfuels.com  
617.720.3835

**HERCULES**  
JOHN REARDON  
NEW BEDFORD, MA  
508.993.0010

**JAMES HOOK & CO.**  
ED HOOK JR.  
BOSTON, MA  
617.423.5500

**JOHN M. KARBOTT**  
**CUSTOM**  
**WOODEN BOAT**  
**BUILDING & REPAIR**  
PLYMOUTH, MA  
508.224.3709  
by-the-sea.com/  
karbottboatbuilding

**KETCHAM TRAPS**  
HEATHER KETCHAM  
NEW BEDFORD, MA  
508.997.4787

**KINGFISHER TRAP**  
CARL HOWARD  
DENNIS, MA  
508.385.5968

**KING LOBSTERS**  
D.J. KING  
BRANFORD, CT  
203.488.6926

**KING MARINE LLC**  
CAPT. GEORDIE KING  
MARINE SURVEYOR  
207.337.8706  
kinggeordie@comcast.net

**LOBSTER CRUISES**  
PAUL QUINTAL  
PLYMOUTH, MA  
508.746.5342

**LOBSTER TRAP**  
**FISH MARKET**  
MONUMET BEACH, MA  
508.759.6400  
lobstertrap.com

**LOBSTER TRAP CO.**  
LOGAN CLARK  
BOURNE, MA  
508.759.4928  
lobstertrap.com

**LYNCH LOBSTER CO.**  
JOHN LYNCH  
BEVERLY, MA  
978.921.8088

**MAIN STREET WIRE**  
DOUGLAS, MA  
508.847.8888

**MARINE HYDRAULIC**  
**ENGINEERING**  
ROBERT CROWE  
ROCKLAND, ME  
207.594.9525 | 800.747.7550

**MILTON CAT**  
**POWER SYSTEMS**  
NICK FAWEL  
MILFORD, MA  
508.207.8542

**MORTILLARO LOBSTER,**  
**INC.**  
VINCE MORTILLARO  
GLOUCESTER, MA  
798.281.0959

**NAHANT FISH & LOBSTER**  
781.592.7500

**NAPA-CAPE COD**  
BILL DRINAN  
FALMOUTH, MA  
508-457-1734

**NAVROC MARINE**  
**ELECTRONICS**  
JASON PHILBROOK  
ROCKLAND, ME  
207.596.7803

**N.E. MARINE &**  
**INDUSTRIAL INC.**  
MIKE RICHARDSON (NH)  
603.436.2836 | 781.834.9301  
Info@newenglandmarine.com

**NEW ENGLAND PROPELLER**  
RON PECK  
PLYMOUTH, MA  
800.635.9504  
neprop@aol.com

**NORTH ATLANTIC**  
**POWER-TWIN DISC**  
SAM PROFIO  
EXETER, NH  
sprofio@glpower.com  
603.418.0470

**PIGEON COVE COOP**  
ROBERT MORRIS  
978.479.3828

**RFP LOBSTER BAIT**  
DICK PERENTZ  
774.248.0292

**RIVERDALE MILLS**  
NORTHBRIDGE, MA  
508.234.8715

**ROSES MARINE**  
MARTY BOLCOME  
GLOUCESTER, MA  
877.283.3334  
rosesmarine.com

**SEA CLIFF LOBSTER**  
FRANK COLLINS  
MANOMET, MA  
508.224.5700

**SPURS MARINE MFG.**  
PABLO SOSA  
FORT LAUDERDALE, FL  
800.824.5372

**SUPERIOR LOBSTER**  
MARSHFIELD-SANDWICH  
774.773.5048  
www.superiorlobster.com

**THE NEW RESULT**  
LOUIS LARSEN  
Mvseafood@vineyard.net

**TWO COUSINS**  
**FISH MARKET**  
BRIAN O'DONOHUE  
FREEPORT, NY  
516.379.5065

**WELLFLEET**  
**SHELLFISH CO.**  
508.255.5300  
sales@wellfleetshell.com

**WINDWARD POWER**  
**SYSTEMS**  
FAIRHAVEN, MA  
774.992.0059  
windwardpower.com

**WOOD'S SEAFOOD**  
JAY KIMBALL  
PLYMOUTH, MA  
508.746.0261  
www.woodseafood.com

**YANKEE FISHERMEN'S**  
**CO-OP**  
SEABROOK, NH  
603.474.9850

**IN MEMORIAL**



***Patrick Joseph  
Bowes Jr.***

It is with heavy heart that we must tell you lifelong MLA member, Patrick Joseph Bowes Jr. (46), of Hull Ma. passed away suddenly on Wednesday November 23rd, 2022 as a result of a heart attack. Beloved son of the late Patrick (SFD) and Connie (Ward) Bowes, Patrick was raised in Scituate and graduated from Scituate High in 1995. While at Scituate High School, Patrick played Varsity Hockey, Varsity Baseball and Varsity Golf.

Patrick graduated from St. Joseph's College in Vermont and was on the baseball, golf and ski teams. Patrick earned a Bachelor of Science and a Business degree from St. Joseph's. Patrick was a talented carpenter and owned his own carpentry business. For years Patrick lobstered with his Dad on his Dad's boat The Katie - Pat. He also fished for Tom Bell on the Michael Brandon and with Phil Lynch on the Mary Elizabeth and Paula Lynn. Most recently Patrick had bought his own boat and was lobstering out of Scituate Harbor.

Patrick is survived by his loving wife of 8 years, Jennifer (Nonenmacher) Bowes and their five-year-old son, Patrick, who idolized his dad.

Patrick was the only sibling and younger brother of Katie (Bowes) Prendergast and her husband Tom. He was the supportive and entertaining uncle to Tommy, Kevin and Jack Prendergast all of Marshfield.

Patrick was the son-in-law of Paul and Dale Nonenmacher and brother-in-law to Paul Nonenmacher.

Patrick leaves behind his faithful dog David. Also left behind are many aunts, uncles, cousin and cherished friends. As one family member said, "There is a huge hole in our family now". Patrick will be greatly missed by the people who loved him... gone too soon, 143

***Steve's Rope Splicing***

Custom Rope Splices

**BUOY LINE MARKING INSERTS**

Massachusetts Vertical Line Solid Top Mark  
NOAA & DMF Approved  
20" Loop for easy attachment to buoy end  
\*Removable Green Federal Marking\*

**\$8**



1200' Spools of  
Red & Green  
3/8" Poly

**\$145**

**978-879-9737**

**StevesRopeSplicing@Gmail.Com**

**Gloucester, MA**

**Make cleanup  
easy and fast.**

**Blast Away!**  
Onboard Pressure Washers  
5.6 GPM @ 3,500 PSI

Our pressure washers  
come with everything you  
need, including 50' hose and  
wand with turbo nozzle.



Belt Driven

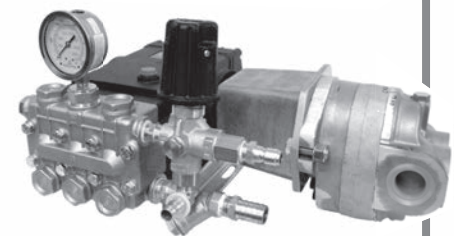

Hydraulic

Salt or Fresh Water

**Coastal Hydraulics, Inc.**

603-474-1914 • sales@coastalhyd.com

www.coastalhyd.com

28 Route 286, Seabrook, NH

# AQUAMESH®

Premium Quality Marine Wire



**Proudly  
Made in the USA  
Since 1980**

***Contact us today to locate  
a distributor in your area!***



1.800.762.6374 • SALES@RIVERDALE.COM • WWW.RIVERDALE.COM



*Service Provider for MLA Non-Profit Boat Protection Cooperative Ltd.*

**MLA's #1 Commercial Boating Insurance Provider**

**Agreed Hull Value – Protection & Indemnity**

**Crew Coverage - Extended Policy Limits - Chartering**

**Marina Floaters - Multiple Fisheries - Deductibles**

**Call now for a free quote 781-545-5073**

**or**

**Request a quote online at [fishermenservices.com](http://fishermenservices.com)**



# As the HAULER TURNS

**The Massachusetts Lobstermen's Association** would like to welcome the following new members to the Association. Your Association will continue its efforts on your behalf to conserve the resource, protect your livelihood, keep you informed, promote the industry and provide you with increasing benefits as they are developed. MLA stands ready to help you in anyway, at anytime — just let us know how! Safe on the water and good fishing!

## NEW MLA MEMBERS:

### LARSEN FOYE

F/V: WhyKnot • Port: Kittery, ME

### THOMAS TURNER

F/V: Sea Raven • Port: Edgartown

### ERIC HESSE

F/V: Tenacious • Port: Barnstable

### SONNY RAY RICH

F/V: Susan Elizabeth • Port: Portland, ME



Published by the Massachusetts Lobstermen's Association, Inc.  
8 Otis Place, Scituate, MA 02066

– Published monthly –

Mailed to all paid members of the Massachusetts Lobstermen's Association

#### Newsletter Departments

Editor, Industry News, Notice Section, Editorial, Blog, Industry News, Promotions, Layout, Advertising:  
Beth Casoni — Executive Director

Buy Sell Swap: Tracey Abboud

#### Newsletter Advertising Rates

The MLA Newsletter is published monthly  
(Please note that all pre-paid ads for last year will be honored)

\$50 — ¼ Page Ad

\$80 — ½ Page Ad

\$110 — Full Page Ad

Color Ads — + \$50 per ad

The MLA is celebrating 60 years of service and dedication this year, 1963-2023, and will continue to do what has been done every day for the last 60 years, fight for you so that you can keep fishing. The world has drastically changed over the last 60 years and the MLA remains battle tested and ready to go wherever needed on your behalf so that your voice is heard.

Wind and whales are the world in which we live in these days and as the saying goes, “If you’re not at the table, you’re on the plate”! When it comes to participating at either whale or wind meetings, the MLA is there so that your concerns are heard as the MLA remains the voice for the commercial lobster industry.

The commercial lobster industry could have received the biggest gift of all as we patiently wait for the President’s signature on the \$1.7 Trillion Dollar Omnibus Spending Bill (Bill). The Bill will put a hold on ANY “new” regulations from NOAA on the commercial lobster industry until December 31, 2028. (Please take the time to read the LDF updates as this will spelled out there from our attorney.)

As of 12/27/22 we have not heard if this Bill has been signed into law or not. Hopefully, by the time you are reading this it will have.

We also celebrate with reservation as the Bill has baked into it an; *[(b) EXCEPTION. —The provisions of subsection (a) shall not apply to an existing emergency rule, or any action taken to extend or make final an emergency*

*rule that is in place on the date of enactment of this Act, affecting lobster and Jonah crab.]* This means that anything NOAA has enacted in the past can be enacted again in the future as an emergency rule. We will keep you posted as more information becomes available.

As for the world of offshore wind, which keeps moving at a whirlwind pace, I am pleased to let you know that I have been appointed as the primary candidate to fill a seat on the Commercial Fisheries Commission for Offshore Energy Projects (COEP) for the Massachusetts Lobstermen’s Association. The COEP is a public body chaired by the Director of the Division of Marine Fisheries and the Director of the Office of Coastal Zone Management and consists of the Secretary of the Executive Office of Energy and Environmental Affairs, as well as 16 public members appointed by the Governor.

The purpose of this public body is to address the responsible development of offshore energy projects; develop and recommend strategies, methods, and tools to assist with mitigation and support the seafood industry; and enable an effective dialogue among seafood industry stakeholders and the other entities involved in offshore energy generation and transmission.

Lastly, please be advised that the Atlantic States Marine Fisheries Commission, American Lobster Management Board, will be meeting on Tuesday, January 31 from 10:15 a.m. – 12:45 p.m.



to discuss the following: Atlantic Large Whale Take Reduction Team Update from NOAA Fisheries, Consider Draft Addendum XXVII on Increasing Protection of Spawning Stock Biomass of the Gulf of Maine/ Georges Bank Stock for Public Comment and, an update from Work Group on Implementation of Addendum XXIX on Electronic Vessel Tracking for Federal Permit Holders. Stay tuned!

Having been with the MLA for 15 years now and Director for 9 years, I continue to learn from each and everyone around me so that I can better serve you all. As the MLA remains one of the most respected commercial fishing organizations in New England and around the Country, I am proud to be working for the MLA and you all, here’s to many more years!

As always safe on the water,

**Beth Casoni**

Director



# New England Marine Engineering & Supply, Inc.

Marine • Industrial • Commercial • Refrigeration

10 TON ELECTRIC TITANIUM RSW  
INTEGRATED MARINE SYSTEMS

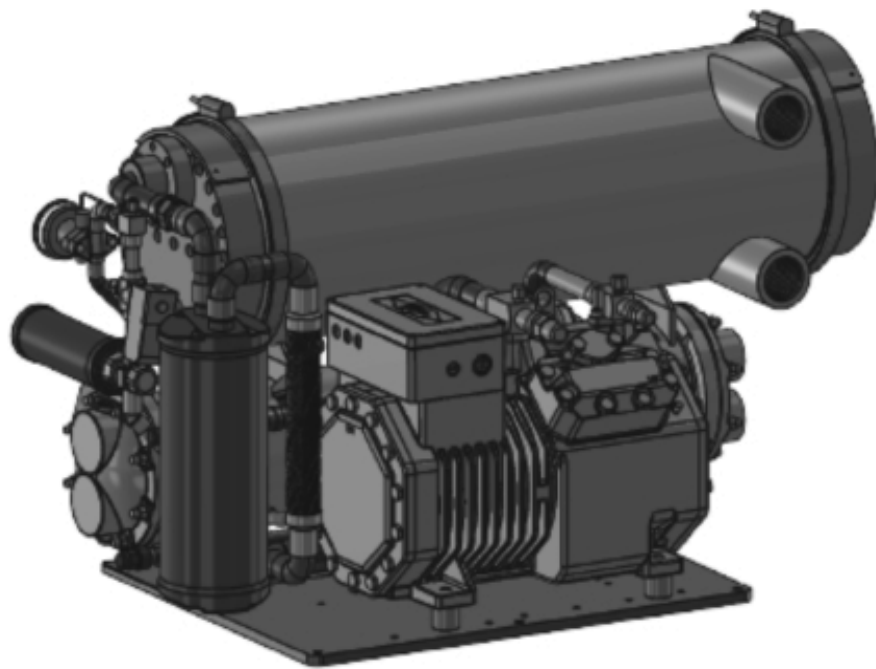

"New England Marine Engineering & Supply, Inc & Integrated Marine Systems, Inc is proud to announce & debut the new IMS 10 Ton Titanium Electric RSW at the 2018 Seafood Processing North America Show on March 11-13 Booth 1875. Come see us and be the first to view the latest IMS system to be introduced to the industry for the fishing vessels ranging from 40' - 80'.

It's going to be the talk of the show."

133 North Front Street, New Bedford, MA. 02740

[www.nemesinc.com](http://www.nemesinc.com) 1.800.540.8893



# Stellwagen Sanctuary Council on Windmills in the Gulf Of Maine and More

The Stellwagen Sanctuary Advisory Council (SAC) held its 66th meeting on October 26th, 2022.

This was another zoom meeting and not an in-person one. The biggest and longest discussion item on the agenda focused on Wind Energy in the Gulf of Maine. Let's begin here.

There will not be any windmills in the Sanctuary. This is the rule now, but that rule could be changed although that is unlikely. The proposed

lease area is east and north of the Sanctuary in a very extensive area of the Gulf of Maine. The concern here, however, is where is the cables from the windmills would come to shore. While there are small transmission cables coming through the Sanctuary now, would these larger cables be able to come through the Sanctuary to reach identified shore locations in Plymouth, Boston, Salem or Everett?

Everyone noted that if electric

cables need to go through anywhere, there should be one channel rather than many lanes. It was also noted that to put any line through, it would require a dredging vessel to dig, lay and cover a cable, even if not through the actual Sanctuary.

These windmills are expected to be floating wind turbines instead of being on stands embedded in the bottom. This would mean that they would be held in place with anchors. SAC members, [Frank Mirarchi](#) (commercial mobile gear) and [Bill Adler](#) (commercial fixed gear) both raised concerns with regard to:

- Buffer zones around the anchors and cables
- Cables and the trenching machine
- The actual anchors for the windmills

These wind turbines are expected to be 1000 to 1200 feet high. Maine has approved putting 12 of these windmills in their areas to study their effects?! Leases for anything in the Gulf of Maine (outside the sanctuary) are expected to be granted in 2024.

There was a motion made and passed to set up a [Wind Energy subcommittee](#) which focus on at least 3 items.

1. Any buffer zones necessary to protect the Sanctuary's resources and uses.
2. Best management practices(?) required of any cable crossing the Sanctuary.
3. Address other scientific questions raised during the process.

The Advisory Council was updated on the [Management Plan](#). The draft was scheduled to be ready for review by "headquarters" in a few weeks. According to the Sanctuary, the final plan should be released in January 2023.

There were also discussions on the work plan which included water quality concerns arising from chemicals, sulfides, algae blooms, ocean acidification and effects on Right

Whales. In the budget agenda item, it was noted that the Sanctuary needs more money (*who doesn't*)!

It needs more funds to cover staffing to help with increases on issues where the Sanctuary will be involved.

The Sanctuary Superintendent, Pete DeCola, responded to SAC member, Bill Adler's questions on the disposal of radioactive waste from the Pilgrim Power Plant and a letter sent to the USCG regarding "Port Access" routing (through the Sanctuary).

Pete noted that he had heard back regarding the Sanctuary's concern on the discharge but the agencies involved were still working on it!? Pete also noted that he had not received any responses from the Coast Guard on his letter regarding the "Port Access" routing issue.

Among other agenda items were updates on the Sanctuary's 30th anniversary, a new eco-system monitoring buoy in the South part of the Sanctuary, a sand-lance report and updates on the scallop fishery. There was, *thankfully*, not much on whales, except for concerns about the effects from windmills, sand-lance depletion and water quality.

*This will be my final report on the Stellwagen Bank Sanctuary's Advisory Council meetings. I have been "termed out" as a SAC member and I am not eligible to be re-appointed by the Secretary of Commerce to hold the Commercial Fixed Gear seat. I've been a member of the Stellwagen Bank Advisory Council since 1999 and have always tried to protect the fixed gear commercial fishermen, (lobster, gillnet and hookers) from being negatively impacted by any federal or other entities on bank activities. We've been successful for the most part. I've been honored to be able to support all of, "my fishermen" and represent them and protect their livelihoods. God Bless!*

*Bill Adler  
Commercial Fixed Gear SAC Member*

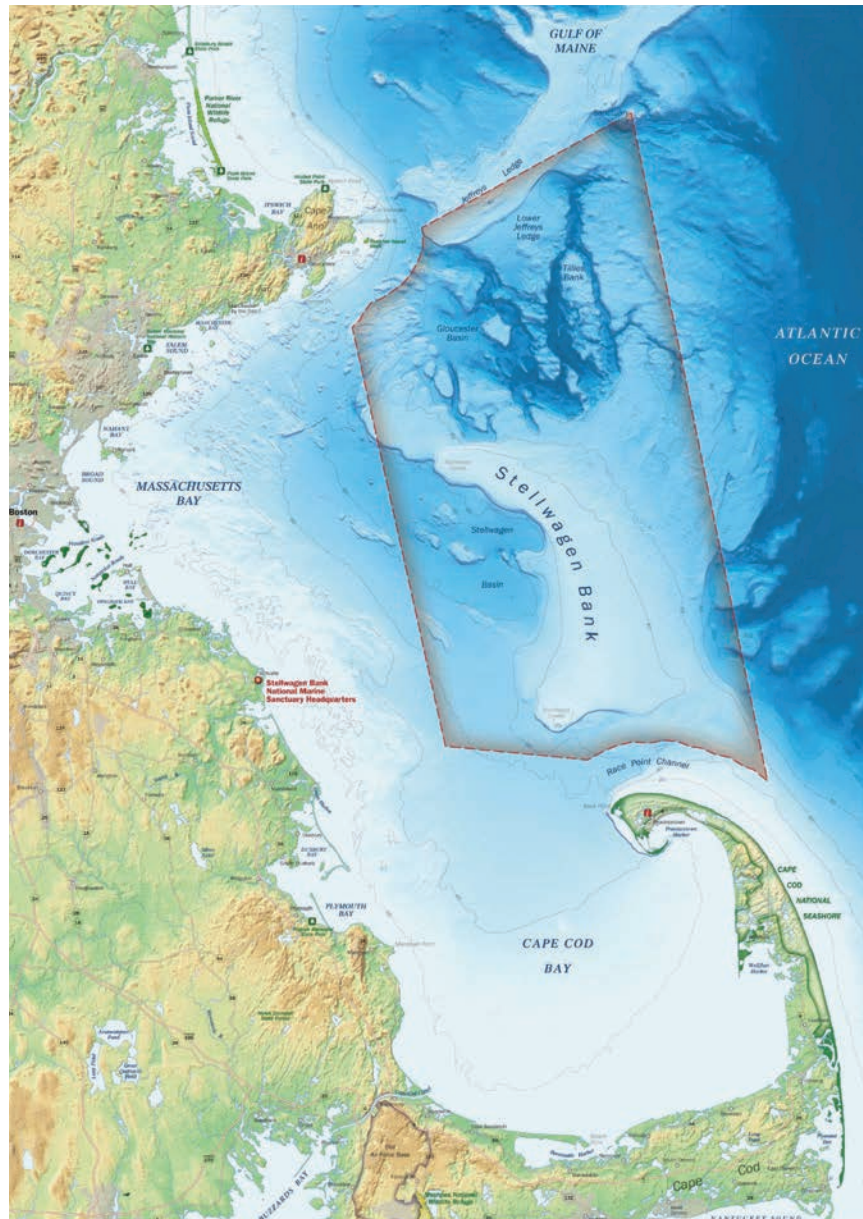

# MLA letter of comment on BOEM-2022-0066

December 6, 2022

Bureau of Ocean Energy Management  
45600 Woodland Road  
Sterling, Virginia 20166

**RE: Docket BOEM-2022-0066 – DRAFT BOEM and NOAA Fisheries, North Atlantic Right Whale and Offshore Wind Strategy**

## To Whom It May Concern:

On behalf of its 1800 members, the Massachusetts Lobstermen's Association (MLA) respectfully submits this letter of comment and concern to the Bureau of Ocean Energy Management (BOEM) regarding Docket BOEM-2022-0066 "DRAFT BOEM and NOAA Fisheries, North Atlantic Right Whale and Offshore Wind Strategy" (Document). Given the extreme sensitivity of any impacts Offshore Wind (OSW) could have on the North Atlantic Right Whales (NARW) not only here in Massachusetts but anywhere they travel, will ultimately have a negative impact on the commercial lobster industry.

Established in 1963, the MLA is a member-driven organization that accepts and supports the interdependence of species conservation and the members' collective economic interests. The membership is comprised of fishermen from North Carolina to Canada and encompasses a wide variety of gear types from fixed gear and mobile gear alike. The MLA continues to work conscientiously through the management process with the Division of Marine Fisheries (DMF), Atlantic States Marine Fisheries, New England Fisheries Management Council, Bureau of Ocean Energy Management and, the National Oceanic Atmospheric Administration (NOAA) to ensure the continued sustainability and profitability of the resources in which our fishermen are engaged in.

The Massachusetts commercial lobster industry employs thousands of individuals in good paying jobs. Per the DMF 2021 Lobster Tables there were an estimated 850 commercial/student lobstermen in Massa-

chusetts are landing over 17 million pounds of lobster with an economic value of 438 million dollars to the local economy. These are real people earning a real living in the commercial lobster industry and the MLA is greatly concerned that any adverse impact to the NARW will further jeopardize this iconic industry.

It is most unfortunate that, the NARW have experienced an Unusual Mortality Event which started in 2017. These losses are devastating as each animal lost, regardless of where it happened or how, impacts everyone that has a vested interest in earning a living on the ocean. While none of these deaths or serious injuries have been attributed to the MA commercial lobster industry, they are still paying the price while working on how to reduce risk.

Currently, the Massachusetts commercial lobstermen are doing more than anyone in the world for the conservation of NARW. We are extremely apprehensive that ANY impact to their feeding grounds or ability to traverse the wind lease area will somehow come back to bite the lobster/fishing industry and become their responsibility.

## NARW CONSERVATION EFFORTS IN THE COMMONWEALTH

The MLA has been actively engaged in the conservation of right whales for over 30 years and remains committed to staying the course.

## MA CLOSED AREAS

The Massachusetts lobstermen have endured most of the draconian whale conservation management over the last several decades since the inception of Critical Habitat in 1994 and most recently the implementation of the 3-month (Feb/April) closure to all pots/traps in the MA Closed Areas. With over 11,000

square miles closed to lobster fishing, removing ALL the vertical lines, when the right whales are present and feeding leaving ZERO chance of an interaction or entanglement, we are extremely anxious going forward with any further management based on; no data, speculation of data or models that were conjured up to accommodate the unrealistic outcome.

The Intersection of NARWs and OSW section in the Document misrepresents where NARWs have been sighted and the overlap between NARWs and OSW; "The overlap between OSW development (planned, leased, and permitted) and NARW habitats extends to corridors outside the immediate development sites, where vessel traffic between ports and off-



## TIMELINE

- 1996** – NOAA implements the Large Whale Take Reduction Plan, MLA is at the table
- 1997** – MA requirement for "breakaway" features in gillnets and trap/pot buoy lines  
Seasonal ban in Cape Cod Bay for gillnets and on use of floating rope between traps
- 1997** – Dedicated aerial surveys begin in Cape Cod Bay
- 2004** – Year-round ban on floating rope between traps in Cape Cod Bay
- 2007** – Year-round ban on use of floating rope between traps statewide
- 2014** – MA Restricted Area is created – 3-month closure Feb-April to 3,071 sq. miles
- 2015** – 3-month (Feb/Apr) closure to all pots/traps in the MA Restricted Area
- 2016** – 3-month (Feb/Apr) closure to all pots/traps in the MA Restricted Area
- 2017** – 3-month (Feb/Apr) closure to all pots/traps in the MA Restricted Area **PLUS** 4-day extension of the gear closure in Cape Cod Bay
- 2018** – 3-month (Feb/Apr) closure to all pots/traps in the MA Restricted Area **PLUS** a 15-day extension of the gear closure and speed restriction (10 mph) for small vessels in Cape Cod Bay
- 2019** – 3-month (Feb/Apr) closure to all pots/traps in the MA Restricted Area
- 2020** – 3-month (Feb/Apr) closure to all pots/traps in the MA Restricted Area
- 2021** – 3-month (Feb/Apr) closure to all pots/traps MA Restricted Area North.
- 2021** – 3-month (Feb/Apr) closure to vertical lines South Island Restricted Area

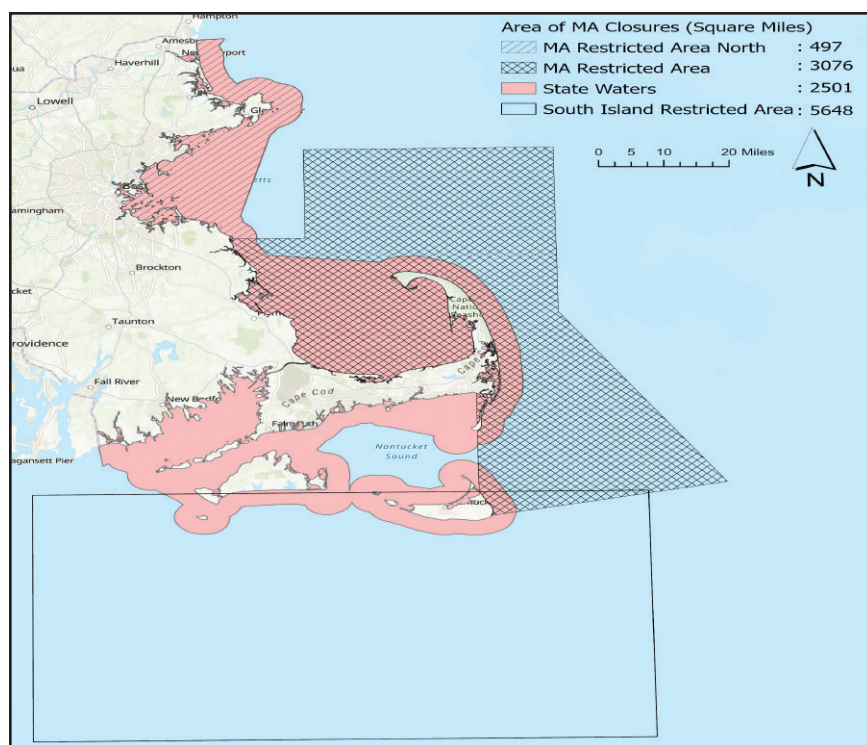

shore sites would further overlap with the distribution of NARWs.” In 2022, there are numerous confirmed sightings in the MA/RI wind lease area, depicted to the above. <https://whalemap.org/WhaleMap/>

We already have overlap between the NARWs and OSW and the impacts are yet to be fully known until this wind lease area is developed as NARWs are unpredictable and have been sighted in areas they have not

historically visited searching for food. Please reevaluate the Intersection between NARWs and OSW.

The Document identified three goals: Mitigation and Decision Support Tools, Research and Monitoring, and Collaboration, Communication, and Outreach. These areas all require more funding which has yet to be determined how it all will be paid for. The MLA is greatly concerned on the negative economic impact these new initiatives will not only have on the commercial lobster industry but the taxpayers. How much more money will be spent on top of the hundreds of millions of dollars? The MLA is requesting that the God Squad be enlisted to do an analysis on the viability of the species and if it can truly be saved. How much more money can be lost by the commercial lobster industry and spent by the taxpayers on a species that has such a low genetic pool and breeding ratio?

In closing, the MLA is greatly concerned about the development of offshore wind in the United States due to potential impacts on the NARWs. The MLA is committed to

working with the commercial fishing industry and BOEM throughout this process to ensure all voices are heard and concerns are vetted. BOEM can make this happen as we are moving forward into the unknown let's move forward in a direction that ALL other projects will adhere to the high standard you set today. Our hope is to look back one day and know that we all did what was right by the commercial fishing industry and the ecosystem we all depend upon.

Thank you for your purposeful deliberation on this most sensitive matter as the Massachusetts commercial lobstermen continue to fish under the most restrictive conservation measures anywhere in the world. Our commercial lobster fishermen deserve to know that their conservation efforts to protect the North Atlantic Right Whales is not in vain as offshore wind is developed on the very grounds they fish.

Kind regards,

*Beth Casoni*

Director

# WINTER WEBINARS

with the  
*Fishery Friendly  
 Climate Action*  
 campaign

January 24, 4:00 pm ET: "Conservative and care about climate change? You have a special role to play."

CLIMATE ACTION LED BY PEOPLE IN BOOTS, NOT PEOPLE IN SUITS!



Learn more: [www.fisheryfriendlyclimateaction.org](http://www.fisheryfriendlyclimateaction.org)



New England Marine & Industrial  
www.newenglandmarine.com

## Lobster Bands

We carry:

Sheddar

Standard

Cold Water Shedder

Jumbo



Buy them by the 1 pound bag, by the case or by the pallet. We also offer wholesale and volume discounts. Call and ask to speak to a salesman.



Dayglo &  
Flexabar  
Buoy Paint



Perone Buoys

Full selection of sizes  
in Stock

### Riverdale/Aquamesh Trap Wire

- Large inventory of trap wire in store
- Variety of sizes and colors available
  - Some trap kits in stock
- Order any size trap kits you may need

200 Spaulding Tpke  
Portsmouth, NH  
603-436-2836

294 Ocean St  
Brant Rock, MA  
781-834-9301

86 Cemetary Rd  
Stonington, ME  
207-367-2692



**YOU  
ARE  
INVITED!**

# Annual Weekend & Industry Trade Show 2023

**March 23-26, 2023**

Located at the Resort and Conference Center at Hyannis

35 Scudder Ave, Hyannis, MA 02601 | [www.capecodresortandconferencecenter.com](http://www.capecodresortandconferencecenter.com)



## A Full Slate of Activities For the Whole Family

- A super exhibition of the latest goods and services that are important to the lobster/ fishing industry as well as Gov. Agencies
- Seminars-Friday and Saturday
- Comedians-Friday evening following dinner
- Craft-Make you own candy bouquet
- Cooking Demonstration-Saturday
- Super MLA Scholarship raffle Fri-Sun
- Banquet Awards Ceremony Saturday evening
- Casino Night Saturday (9-11pm)
- Children's activity room Fri/Sat evening
- There will be many raffles with cash prizes, free drawings and much more!

The Massachusetts Lobstermen's Association is working hard to bring to you the 2023 MLA Annual Weekend and Trade Show with many vendors along with several informative seminars Friday and Saturday.

Even if you're not an MLA member yet!  
Come on down, over or up and join us for the event.

Remember, this is your industry  
why not join the MLA for some fun?

**ADMISSION to the SHOW is FREE**

For more information on membership, room packages,  
seminars and vendor information please visit

[www.lobstermen.com](http://www.lobstermen.com)

**Exhibit Hall Hours: Thu. (setup day) 9:00am-5:00pm, Fri. 9:00am-5:00pm, Sat. 9:00am-5:00pm**

## Are you thinking of buying or selling?

**Boats | State and Federal Permits | Complete Businesses**

ATHEARN MARINE AGENCY, INC.



SERVING FISHERMEN SINCE 1946

Tel: (508) 999-4505

Email: [sales@athearnmarine.com](mailto:sales@athearnmarine.com)

[www.athearnmarine.com](http://www.athearnmarine.com)

10 Union Wharf, Fairhaven, MA 02719





**REGISTER TODAY & JOIN US!**

# Annual Weekend & Industry Trade Show 2023

March 23-26, 2023



Resort And  
Conference  
Center  
At Hyannis

35 Scudder Avenue  
Hyannis, MA 02601  
Main Phone: 508-775-7775

Dear MLA member and Annual Weekend attendee,

In an effort to reduce our carbon footprint on the earth we are now going paperless and all the information and registration forms will be sent out in our weekly emails and are available on the MLAs website Annual weekend page [www.lobstermen.com](http://www.lobstermen.com). If you would like the registration forms mailed to you directly, please call the MLA office and speak with Tracey at 781.545.6984 Ext.2.

The 2023 MLA Annual Weekend and Trade Show is scheduled for March 23rd-26th, 2023 at the Resort and Conference Center at Hyannis, 35 Scudder Ave, Hyannis, MA 02601. <http://www.capecodresortandconferencecenter.com>

If you have not attended the Annual Weekend and Trade show in many years, well then this is the year you won't want to miss out on all the fun and camaraderie. There will be lots of giveaways, raffles, Casino night, great entertainment and laughs with friends you may not have seen in years!

All rooms and booths are on a first come first serve basis. If you would like a specific room or booth location **DO NOT** delay in getting you reservations in early.

The last trade show was a great success thanks to the many MLA members, vendors and show attendees who are dedicated to the fishing industry. The Annual Weekend Committee continues to work hard to bring you new vendors to keep you up to date with all the newest gadgets and equipment in the industry.

If you are interested in helping at the show, please call the office and we will be more than happy to have your help. Let's make this 2023 Annual Weekend one to remember!

See you in March,  
*Annual Weekend Committee*

**Over & Under**  
**Blackjack**

# Casino Night

## 50-50 Raffle



**Roulette**

**Money Wheel**

Pot'O Gold  
Drawn every  
15 minutes

Saturday Night  
**Barnstable II**  
9:00pm-11:00pm



### Kids Activities

(You must Pre-register  
with MLA)

Call Tracey-781-545-6984

When: Friday & Saturday  
Time: 6:00 pm—11:00 pm  
Where: (TBD)

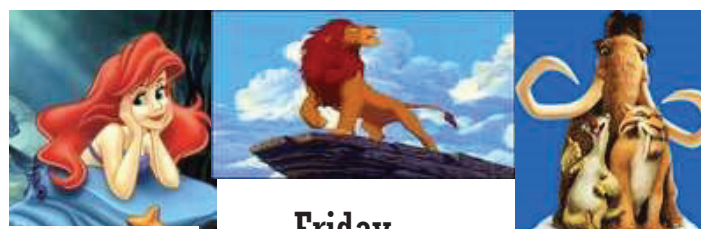

Friday  
&  
Saturday  
night  
movies



**Arts & Crafts  
Games**



Once again, there will be age appropriate activities and movies. Pizza is the food of choice for Friday night and Saturday will be chicken nuggets and French fries along with non-caffeinated beverages and dessert. Do not forget to pre-register your child at the MLA booth. All children MUST be picked up by 11:00 PM. Thank you!



# ***Cape Seafoods Bait Shop Kicking off the Season!***



## **THE LARGEST BAIT VARIETY IN THE ATLANTIC NORTHEAST**

*In operation since 2001 and still going strong!*

### **Trust Us for Your Fresh, Salted & Frozen Bait Needs**

**From (1) Carton to a Full Truck Load.**

**Herring, Mackerel, Pogies, Redfish, Rockfish, Tuna, Monkfish, Sardines,  
Plaice, Squid, Sea Robin, Halibut, & Silversides.**

**We've got you covered!**

**Great News...We now buy Lobster, too!**

**Open Year Round (Serving clients 7 Days a Week from Mid-June To Mid-October)**

**Monday-Friday 5AM-3PM, Saturday 6AM-12PM & Sunday 6AM-10AM**

**Main Phone Line: 978.283.8522**

**Bait Shop Phone Line : 978.479.4642**

***If we don't have it... Please ask and we'll find it!***

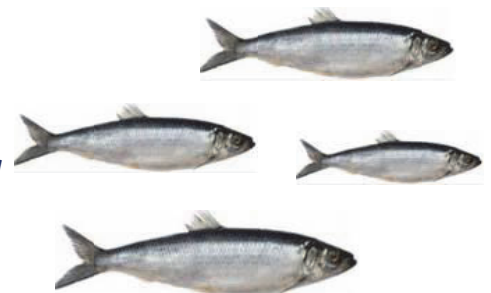



# From the Director's Desk, "Red-Listing" of Lobster: Misguided & Counterproductive



In September, the California-based Monterey Bay Aquarium's Seafood Watch "red-listed" American lobster caught in the U.S. and Canada. Seafood Watch claims that the lobster fishery poses an entanglement risk to endangered North Atlantic right whales and recommends that consumers avoid purchasing lobster. The red-listing was also extended to all fisheries in the Northeast that deploy vertical buoy ropes that could entangle wildlife such as right whales and leatherback turtles.

This unfortunate decision is counterproductive to ongoing efforts by DMF and the industry to further reduce entanglement risk. Throughout this past November, state and federal officials working with teams of fishermen met to devise plans to further reduce entanglement risk as mandated by recent federal court decisions. Then, in early December, the federal Large Whale Take Reduction Team met for two days to review and combine these into regional strategies affecting all East Coast fixed gear fishermen.

Advising consumers NOT to buy lobsters, crabs, and fish taken with buoyed fixed fishing gears is a colossal mistake. As fishermen are adjusting to new regulations and making personal sacrifices, they need our support. Fishing will become less profitable due to the costs incurred by the need to comply with complex regulations to

protect right whales. This is not the time to strip the industry of much-needed revenues for their hard and honest work delivering seafood. This is not the time to turn our backs on these small-scale, owner-operated, family businesses. If consumers heed the call to boycott these fish and shellfish, our local fisheries may not survive. The economic, cultural, and historic value of these fisheries would be lost.

Consumers need to have confidence in the seafood industry and know that hard-working, honest, and innovative fishermen are solving these problems. Seafood Watch's inclusion of the Massachusetts lobster fishery in the blanket red-listing of the entire U.S. and Canadian lobster fishery ignores data provided by DMF to explain state fishery management and right whale conservation measures. It also ignores substantial conservation steps undertaken by DMF and the state lobster fishery to prevent and mitigate entanglements.

Massachusetts lobster fishing regulations are stricter than any other jurisdiction in the United States. Lobster harvesters are required to remove all fixed gear from the water from February 1 through May 15, when right whales are abundant in Massachusetts waters (with the possibility of an extension of closure depending on whether right whales stay longer). During the open season, when right whales are rarely seen in Massachusetts waters, lobster fishers are required to use "weak rope," with breakaway links built in, that has a high probability of parting should a whale encounter it. The development of this weak rope was pioneered by the lobster fishery. It is scientifically designed to be in a pragmatic "sweet spot"; strong enough for the traps to be hauled, yet weak enough to break if right whales encounter it. Finally, all buoy lines used in the U.S. lobster fishery are now required to be



marked to reveal geographic origin. The marking scheme required for the Massachusetts lobster fishery is more distinctive than any other jurisdiction. Should a future entanglement occur, DMF will be able to determine if it is due to Massachusetts-based lobster gear and will be able to take appropriate actions to prevent future entanglements.

All of these reforms and improvements have been made in consultation and cooperation with the fishing community. All have required adjustments and sacrifices, and all have come with costs. Massachusetts fishermen have proven time and again that they are committed to fishing in ways that will protect right whales, and maintain a fishery and habitat for the next generation. For these historic and heroic fishermen to be demonized by a blanket "red-listing" that does not account for their responsible behavior is unconscionable.

These incremental, successful efforts are very different from proposals now surfacing to create what is called a "ropeless" fishery, trying to eliminate any vertical lines that identify pot and gear locations on the ocean floor. "Ropeless" is far from a panacea. It is expensive, and while technically it can work, it creates myriad practical problems on the water in terms of gear

conflict, safety, and enforcement issues; viable "ropeless" technology and best practice is probably at least a decade away. In the meantime, the leadership shown by Massachusetts lobstermen should be adopted everywhere, and that, not driving them out of business, is the best step forward and the best way to protect right whales -- right now.

We at DMF are committed to the recovery of the endangered North Atlantic right whale and appreciate that many conscientious seafood consumers want to support marine conservation goals by choosing sustainable seafood. We also do not want to lose these culturally important legacy industries along our waterfront. We will continue to work to keep fishers fishing and delivering the best and healthiest seafood anywhere. DMF's Seafood Marketing Program will work to educate the public on our conservation endeavors and continue to encourage the consumption of our healthy, local, sustainable and fresh seafood.

By Dan McKiernan  
Director of DMF  
12/23/2022

[https://www.mass.gov/news/from-the-directors-desk-red-listing-of-lobster-misguided-and-counterproductive?utm\\_medium=email&utm\\_source=govdelivery](https://www.mass.gov/news/from-the-directors-desk-red-listing-of-lobster-misguided-and-counterproductive?utm_medium=email&utm_source=govdelivery)



# 2023 U.S. – Canada Lobster Town Meeting

3-4 February 2023 Portland, Maine

## The U.S.-Canadian lobster fishery & the North Atlantic right whale

### Friday — February 3

- 8 am – 4 pm
  - Session I - Prevention and mitigation measures
  - Session II - Market Impacts
  - Session III - Shifting Distributions & Movements in a changing climate
- 4:30 – 6:30 pm Seafood Reception & Poster Presentations

### Saturday — February 4

- 8 – 11:30 am
  - Session IV - Future Innovations - Solutions/ R&D/ New Technology/ ELogs
  - Wrap up

**Venue:** Mariner's Church Event Center, 368 Fore Street

**Accommodations:** Hilton Garden Inn Downtown Waterfront, 65 Commercial Street

A registration fee of **\$75 per person** includes all sessions, select meals & Seafood Reception  
The Hilton Garden is providing a group rate of **\$117/room/night** available for February 2, 3, 4 & 5

**Register online:** <https://umaine.edu/lobsterinstitute/events/>

For assistance on registering, travel assistance, or other questions, contact Chris at:  
[christina.cash@maine.edu](mailto:christina.cash@maine.edu) or 207-581-1443



# Amitié Submarine Telecommunications Cable Installation in US Waters

Installation of the Amitié Segment 1.1 Fiber Optic Cable from Lynn, Massachusetts to the Canadian boundary line is anticipated in winter 2023. The planned route is shown on the attached sketch and route position list. Commercial fishing vessels chartered as scout boats will run the route

before operations to check for fishing gear and notify gear owners. Route clearance with pre-lay grapnel by Atlantic Merlin is expected to start near the Canadian boundary on or about January 16, before installation and burial by the Cablesheet Decisive starting in Nahant Bay, Massachu-

setts on February 1. The end of operations near the Canadian boundary is expected in March 2023. Mariners are asked to stay at least 1 nautical mile away from a working cablesheet (displaying lights red-white-red vertically and by day the shapes ball-diamond-ball); or ¼ NM from a

temporary cable end marked by a yellow buoy with a flashing yellow light. We also kindly request that any set or drifting gear, such as pots/traps, gillnets and longlines, be moved away from the route by a distance of ¼ nautical mile on each side during the installation to avoid entanglement.

## Route Overview

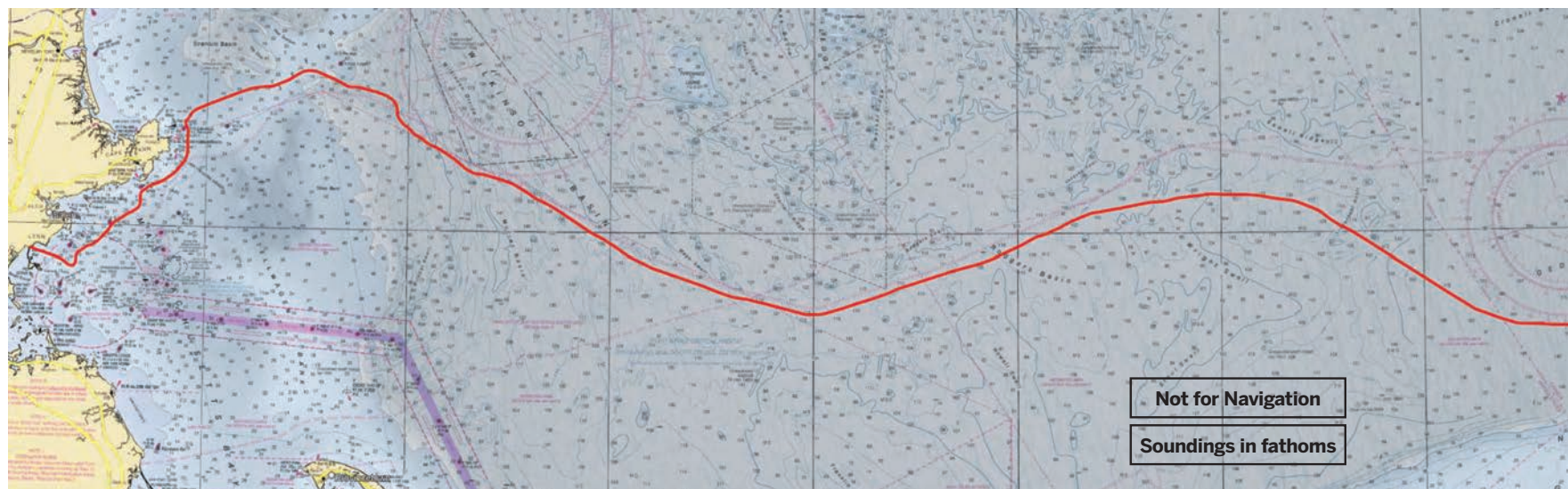

**“The Amitié fiber optic cable will carry internet, telephone, and data between the United States and Europe. Subsea cables carry more than 95% of overseas communications, with more capacity, speed, and security than satellites.”**



## Horizontal Directional Drill exit – Lynn, Massachusetts

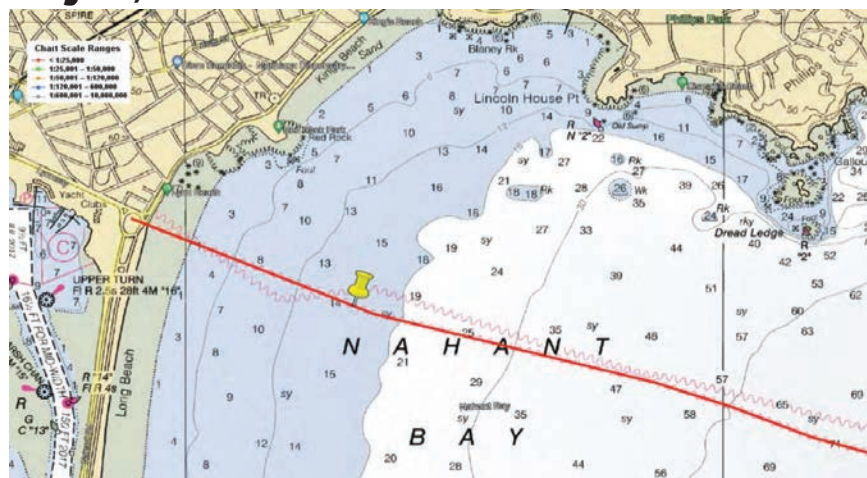

## Cablesheet DECISIVE (Cable Installation)



Call Sign: KDEU  
MMSI 367450000  
Length: 140m (460 ft)

+1 206-274 -8943 (Master)  
+1 206-274 -8941 (VSAT Bridge)  
csdcmaster@subcom.com





**ALCATEL  
SUBMARINE  
NETWORKS**



**Route Clearance**  
Atlantic Merlin  
Call Sign XJBN  
MMSI: 316027612,  
Length: 85m (279 ft)

**Post Lay Inspection/Burial**

M/V Ile De Molene [PLIB Vessel]  
MMSI: 228411900  
Call Sign: FMPZ – Length 93m-305 ft  
Email: master@iledemolene.lida.fr  
Tel cell: +33 (0)7 60 87 78 15  
Tel VSAT: +47 2413 4931  
Tel Iridium: +881 677 114 274



29 Dec 2022

**Scout  
Boats**



FV Karoline Marie  
Call Sign WDE8258  
MMSI: 367403380  
Length: 14m (47 ft)  
Capt. Tom Hill  
Tel. 978 697-5821



FV Becky Lynne  
Call sign WDG6685  
MMSI 367559610  
Length: 24m (78 ft)

**OVER 20 YEARS EXPERIENCE ~ ALL MATERIALS & SIZES**

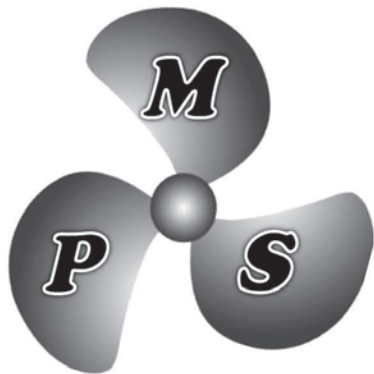

**MARINE**  
PROPELLER SERVICE

**FOR FAST SERVICE  
CALL MIKE @  
508.979.8000**

marine.propeller128@gmail.com

**REPAIRS &  
RECONDITIONING**  
(Fast & Fully Insured)

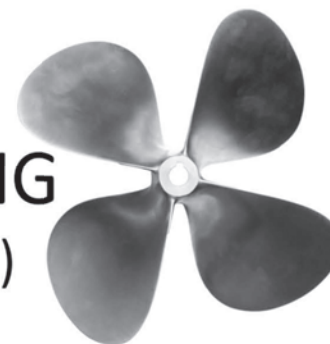

*THE MOST RELIABLE PROPELLER SERVICE COMPANY ON THE SOUTHCOAST*

**74 MAIN STREET FAIRHAVEN MA 02719 508.979.8000 FAX 774.206.6449**

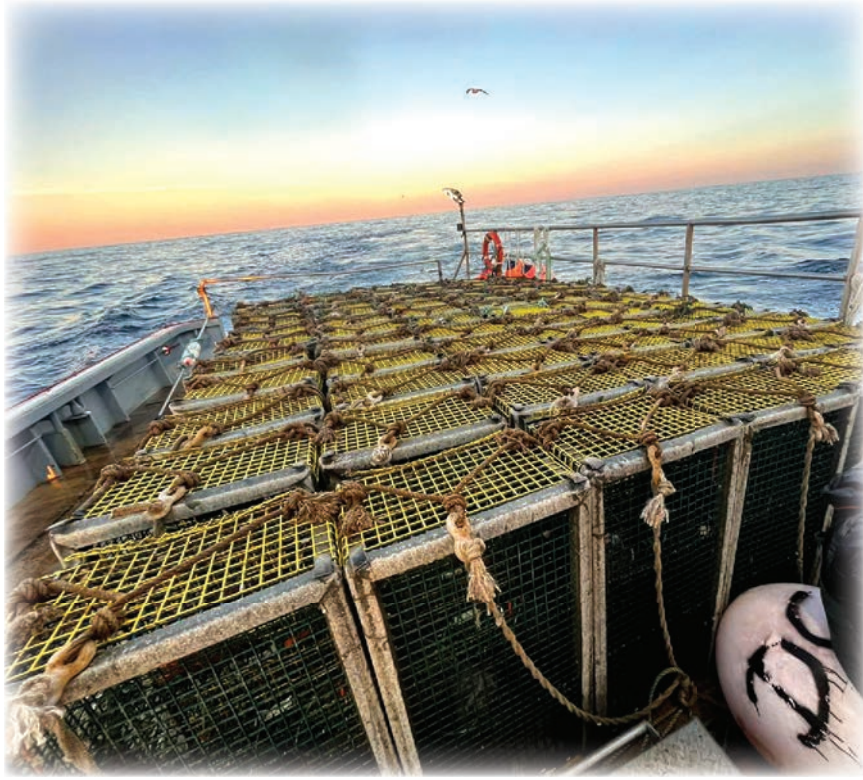



**HERCULES**  
SLR (US) Inc.  
MARINE • FISHING GEAR • SAFETY

44 South Street, New Bedford, MA 02740  
Phone: 508-993-0010 Fax: 508-993-9005  
**Securing – Lifting - Rigging**  
82 MacArthur Dr. New Bedford, MA 02740  
Phone: 508-992-9519 Fax: 508-992-9419



[www.Hercules-SLR-US.com](http://www.Hercules-SLR-US.com)

[JohnReardon@Hercules-SLR-US.com](mailto:JohnReardon@Hercules-SLR-US.com)

USCG Safety Inspection Station #327

**Commercial Fishing-Marine Safety-Rigging**

- ❖ Marine Hardware
- ❖ Cotesi - Netting, Leaded/Sink Rope
- ❖ Stormline & Climate Technical-Foul Weather Gear
- ❖ Buoys & Floats
- ❖ Lobster Bands
- ❖ PFD's, Vests, Float Coats
- ❖ Fish Totes
- ❖ Insulated Tubs
- ❖ Cordage & Twine
- ❖ Mooring Equipment
- ❖ Boarding Ladders
- ❖ Polysteel Rope- Esterpro Sinking, Hydropro
- ❖ Leadline
- ❖ Wire Rope - FC Galv, IWRC, Dyform
- ❖ HiFlyers 12', 14' & 15' XHD
- ❖ Golf & Batting Cage Netting



Inflatable PFD's



**Life Raft Sales**

- ❖ Revere
  - ❖ Elliot
  - ❖ Survitec
  - ❖ Switlik
- All brands accepted for service



Fenders & Buoys-All Colors



**ACR Electronics**  
Sales & Service  
for your E.P.I.R.B.



Boots from  
Honeywell Safety

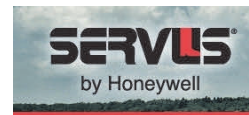

**On-Board Vessel Inspections & Safety Drills**

Call our USCG Certified Drill Conductors:

Rodney Avila 508-889-0401

Ted Williams 508-264-5779



**Imperial**  
Survival Suits  
Sales & Annual  
Inspections  
Done in house



# 12th International Conference & Workshop on Lobster and Crabs

22-27 October 2023 in Fremantle, Western Australia

The Organising Committee of the 12th International Conference and Workshop on Lobster and crab are pleased to announce the go ahead of this workshop that was originally planned for October 2020 for the **22-27 October 2023**. Please check the website for updates on the conference. <https://icwl2023.com.au>

The overall theme for the 2023 workshop is 'ecosystem-based fisheries management (EBFM)' as this generally represents best practice for fisheries management and reflects that fisheries research and management focus is now broader than just sustainability. Therefore we hope to attract presentations

that cover a wide array of subjects under the EBFM banner including biology, stock assessment, management, ecosystem effects of fishing such as interaction with whales, habitat, economics, social, governance and management compliance.

We will be holding a **2-day EBFM workshop** which will be sponsored by the OECD Co-operative Research Programme: Biological Resource Management for Sustainable Agricultural Systems. This will occur on the first two days of the 5-day conference.

While this conference comes back to Western Australia where the 1st International Lobster Workshop was held in 1978, we

have adopted the approach of the 2nd lobster conference in St Andrews in 1985 where **crab presentations** were welcome. We look forward to their participation in this conference.

An **industry day** is also planned for Thursday 26 October and this is an important component of the program so we are looking forward to strong support from lobster and crab industry participants around the world. We are also keen to attract papers on **lobster and crab aquaculture** as this has been an important developing industry in Asia.

Students can apply for the **Paul Kanciruk Student award** for financial support to attend

the conference.

The Department of Primary Industry and Regional Development (DPIRD) and the Western Rock Lobster (WRL) council are looking forward to hosting scientists, managers and industry participants in Western Australia in 2023. Don't hesitate to contact us or the conference organisers, Arinex, if you have any questions.

Co-hosts of the workshop:

Nick Caputi  
DPIRD

[nick.caputi@dpird.wa.gov.au](mailto:nick.caputi@dpird.wa.gov.au)

Nic Sofoulis  
WRL

[sofs1@bigpond.com](mailto:sofs1@bigpond.com)



Encore Hartco Tools & Clips  
Stanley Spenax Tools & C-Rings  
Wematic Tools & D-Rings  
Simonds Pneumatic Wire Cutters  
Spotnail Staplers & Staples

Complete Parts Inventory  
Tool Repair Service



(781) 826-2522  
Fax (781) 826 5252  
[www.fisherairfasteners.com](http://www.fisherairfasteners.com)  
[chris@fisherairfasteners.com](mailto:chris@fisherairfasteners.com)



# NET YOUR PROBLEM

Got old gear lying around you have no idea what to do with? Well you are in luck because **Net Your Problem** has come to town! What is **Net Your Problem** you ask? Well, we work with coastal communities, recyclers, manufacturers and brands to contribute to the blue and circular economies by recycling end of life fishing gear. Founded in 2017 in the Aleutian Islands of Alaska, we pride ourselves in transparency and the positive relationships that make our programs a success. We've enjoyed forming unlikely partnerships and expanding our programs geographically to help prevent marine pollution and champion the social, economic and envi-

ronmental benefits of recycling! Since 2017, we have collected over 1.2 million pounds of end of life gear and are working in 12 different communities around the US.

What is end of life gear, the blue or circular economy you ask? Essentially, we take your old gear that you would otherwise throw away, burn or keep in your front yard for way too long, and separate it into the different types of plastic it is made of, ship it to a recycler and they turn it into the raw material needed to manufacture plastic products. Think of the little nurdles or beads of plastic needed to make sunglasses, picnic tables, kayaks, knife handles, dock cleats... There are so many things in your everyday life that are made from plastic that can instead be made from recycled plastic - and we are at the bottom of that supply chain - kinda like the truck that picks up your bins from the end of your driveway if you have a municipal recycling service.

How can you get involved in such a cool program you ask? Well we have recently acquired a warehouse in New Bedford at 143 King Street, where collections will occur. Caitlin (more about her below) will be there on Tuesdays starting 1/17/2023 from 9am-2pm. She will also be at the MLA annual weekend in March. We can accept most kinds of fishing gear, from trawls to seines to gillnets and of course lobster rope. MLA is even partnering with Net Your Problem to facilitate a rope swap in 2023, so get ready and excited! New rope should be available starting in March, but old rope can be turned in now for recy-



cling in exchange for a voucher that will be valid when the rope is available.

If you wanna know a little more about who you will be working with, Caitlin is new to NYP as of November, and grew up lobstering out of Provincetown, alongside her father, Chris Townsend. From a young age, Caitlin has had a passion for the fishing industry and finding ways to connect the industry with science. She graduated Massachusetts Maritime Academy in 2021 and immediately found intense passion in her hometown fisheries and science,

leading her to work alongside local fisherman collecting ghost lobster gear with the Center for Coastal Studies, and walking along Cape Cod's beaches collecting marine debris. Caitlin is so excited and passionate about creating a program for end of life fishing gear in Massachusetts, ultimately giving back to the fishery that raised her and continues to support her and you can contact her at [caitlin@netyourproblem.com](mailto:caitlin@netyourproblem.com) or 774-316-0417 for more information. Thanks for reading and we hope to see you and your old gear sometime soon!



EXAMPLES OF PRODUCTS MADE FROM FISHING GEAR



# WE DELIVER FRESH LOBSTER BAIT

**INCLUDING:**

HERRING

POGIES

MACKEREL

RED FISH

SKINS

BLUEFISH

CHUM

SALMON  
HEADS



***FRESH, SALTED, AND QUICK FROZEN BAIT***

## **Barrel Head Bait**

***WE SELL SALT!***

**For More Information:**

**To Place An Order:**

**Mark Flight**

**mark@barrelheadbait.com**

**The Bait Line:**

**857-200-2129**

**Or Fax:**

**617-561-8471**

# January Store Special



*Store Hours*  
*Mon – Fri:*  
*8am – 4pm*

**Seamaster**  
**Buoys**  
**8 X 15"**

**\$13 ea.**

*While Supplies Last!*

111 Myrtle Street  
New Bedford, MA 02740  
508.997.4787



[www.ketchamsupply.com](http://www.ketchamsupply.com)  
[info@ketchamsupply.com](mailto:info@ketchamsupply.com)  
f @ketchamtraps



## VINEYARD WIND

# Vineyard Wind 1 Update

## December 2022

Offshore Export Cable Installation for the Vineyard Wind 1 project started late October 2022 and as of December 15, 2022, three segments of cable have been buried with no exposed cable.

The CABLE ENTERPRISE installed 2 of the offshore segments of cable with assistance from the anchor handling tug NORNE.

The NORNE had fisherman Tom Donovan on board to assist with communication as the Onboard Fisheries Liaison, and the F/V FLEET KING operated as a safety vessel to monitor and facilitate the safe movement of fishing vessels, recreational craft, or other transiting vessels around the work sites and project vessels.

Nearshore operations off Covell’s beach in Barnstable started simultaneously in October where vessel activity was busy close to shore to prepare for the cable pull in.

F/V TENACIOUS II was on the scene to monitor a safety perimeter around daylight shoreside activities, and when the cable laying vessel ULISSE arrived to start cable installation the Hyannis based recreation fishing vessel HELEN H arrived on the scene to monitor a safety perimeter as the installation vessel progressed from shore south through Nantucket Sound.

Installation activities for the three remaining cable sections are anticipated to start mid – January 2023.

Below are the nearshore / offshore cable section charts.

**For the latest information, please contact:**

**Crista Bank, Fisheries Manager, Cell: 508-525-0421  
Email: [cbank@vineyardwind.com](mailto:cbank@vineyardwind.com)**

**Jeannot Smith, Marine Liaison, Cell: 904-613-0134  
Email: [jsmith@vineyardwind.com](mailto:jsmith@vineyardwind.com)**

**VineyardWind.com • [info@vineyardwind.com](mailto:info@vineyardwind.com) • 508-717-8964  
700 Pleasant Street, Suite 510 • New Bedford, MA 02740**



### FLEET KING

Flag: USA • Length: 76’ • MMSI#: 367751630  
Captain: Matt Linnel



### HELEN H

Flag: USA • Length: 85’ • MMSI#: 367554870  
Captains: Dylan Phaneuf / Tyler Huckermeyer



### TENACIOUS II

Flag: USA • Length: 40’ • MMSI#: 367400280  
Captains: Eric Hesse



# VINEYARD WIND

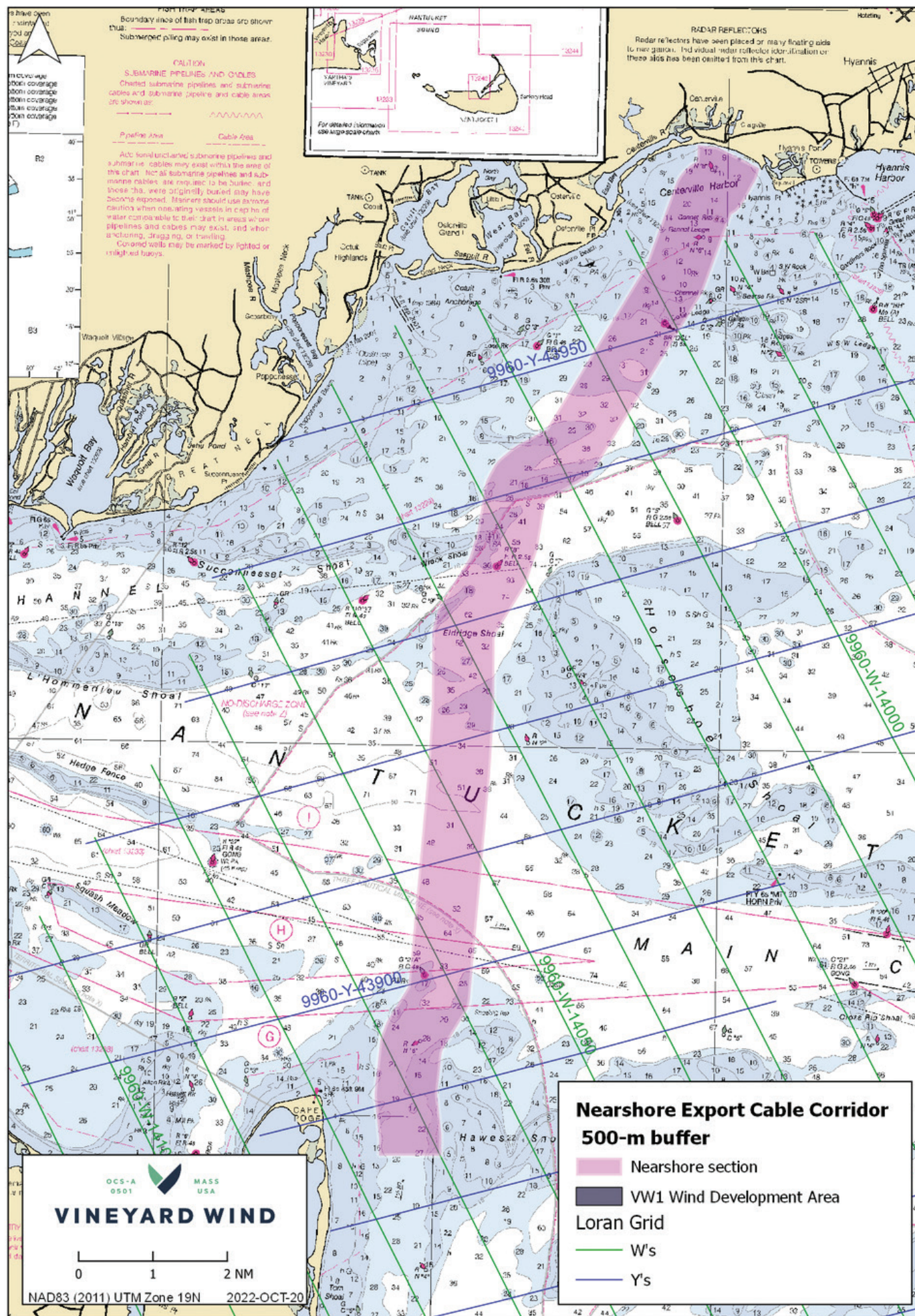

# VINEYARD WIND

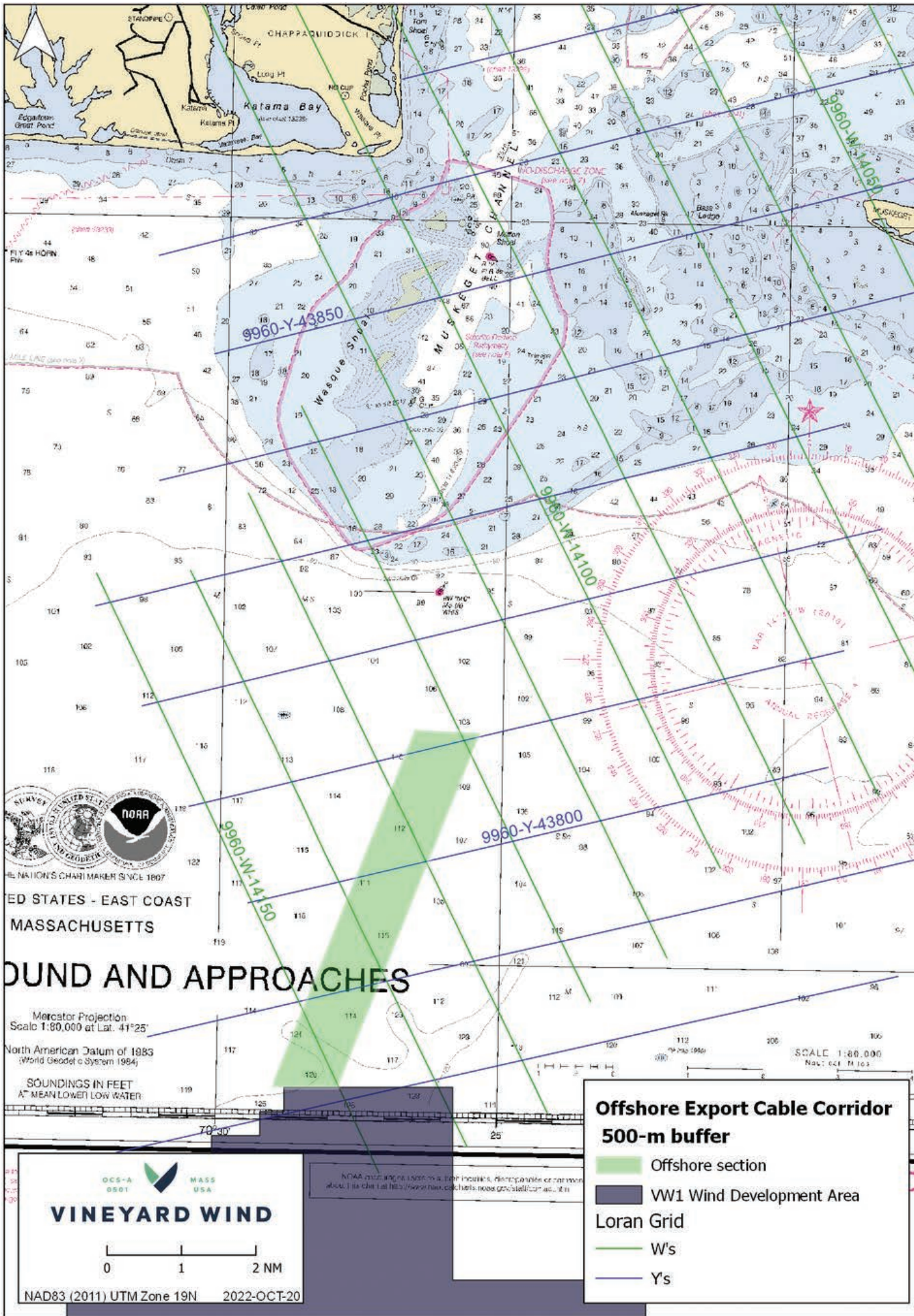



# Rose Marine

Gloucester, MASS [www.rosesmarine.com](http://www.rosesmarine.com)

Aqualoy Stainless  
Propeller Shafts & Accessories



Largest stock of **Aqualoy** Prop  
Shafting on the East Coast.  
*Emergency* turn-around time available.



Call or e-mail Peter Tetrault  
for a price.  
[peter.tetrault@rosesoil.net](mailto:peter.tetrault@rosesoil.net)



**877-283-3334**



**Hydraulic Hoisting Winch**

Four Models from  
2,850lb – 12,300 lb Pull Capacity



Quality Oil Coolers  
Made in the U.S.A



- All Seamless Tubing
- High pressure available
- 90/10 copper-nickel

## Mufflers and Exhaust Components



Stainless Steel Mufflers  
2" – 8" inlet size in stock



## Anchor Flush Mount Hatches

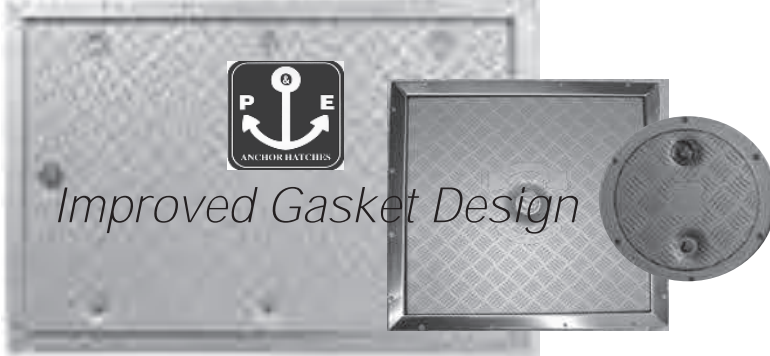

*Improved Gasket Design*



Controls



**Cablecraft**  
PUSH-PULL CONTROLS

*Ask for the  
Green Marine*





# The Commonwealth of Massachusetts Division of Marine Fisheries

(617) 626-1520 | [www.mass.gov/marinefisheries](http://www.mass.gov/marinefisheries)



**CHARLES D. BAKER**  
Governor

**KARYN E. POLITO**  
Lt. Governor

**BETHANY A. CARD**  
Secretary

**RONALD S. AMIDON**  
Commissioner

**DANIEL J. MCKIERNAN**  
Director

December 1, 2022  
*MarineFisheries Advisory*

## 2022 Commercial, Dealer, and Special Permits Extended Through February 28, 2023

Due to delays in the generation, mailing, and processing of 2023 permit renewal applications, the Division of Marine Fisheries (DMF) has extended the validity of 2022 commercial, dealer, and special permits through February 28, 2023. Active permit holders will need a valid 2023 permit beginning on March 1, 2023.

This delay is being caused by DMF's switch to a new permitting system for the 2023 permit year. More information will follow on the system and updated permit design in the coming weeks.

Permit renewal applications are scheduled to be mailed during the third week of December. A follow-up notice will be emailed and posted when renewal applications have been mailed. Once received, please return your completed renewal application(s) and payment in the return envelope that comes with your renewal or bring them to our [Gloucester](#) or [New Bedford](#) offices for processing.

**Limited Entry Permit Renewal Deadline Reminder:** Renewal applications for limited entry permits or permits that have limited entry endorsements or a striped bass endorsement must be received in our office or postmarked by February 28, 2023.

**Boston Office Closed for Walk-in Permitting:** Please note, walk-in permitting services are no longer available at DMF's Boston office. DMF's office at 251 Causeway Street will be closing by early spring due to a broader consolidation of state offices on the Boston campus. Full DMF permitting services will be available at our [Gloucester](#) and [New Bedford](#) offices.

If you have any questions, please email us at [marine.fish@mass.gov](mailto:marine.fish@mass.gov).

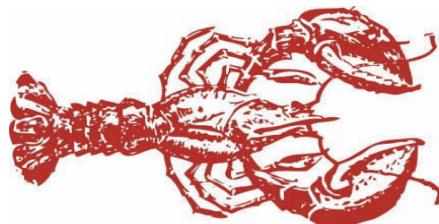

**“Specializing in the sale & delivery of  
LOBSTER BAIT  
for over 30 years”**

**FRESH FROZEN AND SALTED BAIT AVAILABLE**

**SKATES ~ HERRING ~ POGIES ~ HADDOCK ~ COD FISH ~ POLLOCK  
FLAT FISH ~ FISH SKINS ~ RED FISH ~ DOG FISH HEADS ~ SALMON**



**C & P BAIT**  
33 Wright St  
New Bedford, MA 02740

**Contact:**  
Danny Costa 508-951-9818  
Carlos Pereira 508-951-9819



# NEW ENGLAND PROPELLER, INC.

Distributor of Michigan Propellers

**Inboard • Outboard**

Next Generation 3D Computerized Propeller Analyzer  
Computerized Dynamic Balancing



## Marine Fuel Tanks

Custom Fabricated & Tested to U.S.C.G Specifications  
*By Capeway Welding*

- Marine Propeller Sales & Repairs - ***4000 Props in Stock***
  - Sierra Engine Parts for All Outboards & IOs
  - CDI Electronics • Camp & Godfrey Zincs
    - NGK Spark Plugs
  - Duramax Cutless Bearings • Spurs Line Cutters
    - PSS Dripless Shaft Seals
  - Buck Algonquin - Struts, Rudders & Stuffing Boxes
    - S/S Shafting • Drive Savers • Globe Impellers



9 Apollo Eleven Rd., Plymouth, MA 02360  
Tel: 508-747-6666 800-635-9504 - [neprop.com](http://neprop.com)

December 15, 2022

Arthur Sawyer  
Massachusetts Lobstermen's  
Association  
8 Otis Place  
Scituate, MA 02066

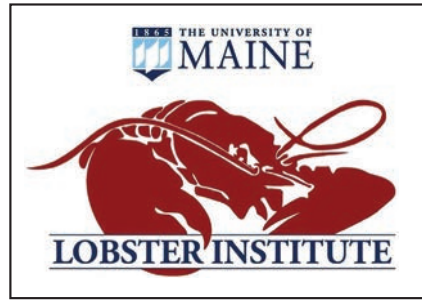

Dear Sooky,

We hope this letter finds you healthy and enjoying the holiday season.

As we wrap up 2022, we'd like to share a few highlights of the very productive year, and ask for your help to bolster our undergraduate and graduate opportunities in 2023!

Probably the Lobster Institute's biggest accomplishment in 2022 was to land a \$3 million award from the National Science Foundation's Navigating the New Arctic (NNA) program. The new *NNA Lobster Network* launches on January 1, 2023. A collaboration between UMaine, the Gulf of Maine Research Institute, Columbia University, Florida State University, and Memorial University of Newfoundland, the project builds on long-standing partnerships with the fishing industry, government agencies, and academia in New England and Atlantic Canada. The project is well timed to meet the urgent need to understand the increasingly apparent links between a rapidly warming Arctic and ecosystem changes in the Gulf of Maine, the Gulf of St. Lawrence, their fisheries, and communities that depend on them.

We also look forward to an active year of in-person events. After a two-year COVID-imposed hiatus, we will again host our marquee winter gathering: the 18th *U.S. - Canada Lobster Town Meeting* on February 3 & 4, 2023, in Portland. The theme for this Town Meeting is the North Atlantic whale and the lobster. Mark your calendars to participate in this unique chance for cross-border dialog among fishermen, managers, and researchers. Following Town Meeting, our outreach efforts continue with the Sea Grant American Lobster Initiative's *Regional Lobster Research and Outreach Summit*, also in Portland, February 6-8, 2023, followed by the *Maine Fishermen's Forum* in Rockport, Maine, March 2-4, and then the *Massachusetts Lobstermen's Annual Trade Show*, March 23-26, in Hyannis, MA.

We're proud of these successes, but we also face challenges. Since I came on board as director in 2018, we've been able to steadily increase the number of graduate assistantships and undergraduate internships we can support through internal and external sources. With the university facing budget shortfalls this year, without your support we do not anticipate being able to sustain this trend. This year's annual appeal therefore takes a focus on student support.

Working together we can make a lot of good things happen. Indeed, collaboration is the backbone of the Lobster Institute. We therefore thank you for your partnership and ongoing support.

Very best wishes to you for a Happy Holiday and new year!

Richard A. Wahle  
Director, Lobster Institute



## PROVEN PERFORMERS! Rockbottom Runners



Our precision formulation and process has been refined over the years to provide the optimum balance of strength and flexibility... – and the vise test shows it

Over **20 YEARS**  
of fishing;

Well over **HALF  
A MILLION** sold



*Could you do this with  
any other concrete runner?*



Over **6 YEARS**  
of fishing.

Over a **QUARTER  
MILLION** sold



**OCEAN-TESTED** for years...  
aircraft carrier decking and  
pilings in the marine borer  
intense Panama  
Canal Zone.

*The toughest species  
of junglewood we've found  
... and the only kind we sell.*

**We are constantly listening to our customers:  
Your feedback + continuous improvement  
= proven reliability**

### Here to serve you!

**Jerry Wadsworth** (207) 542-0842 jerryw@friendshiptrap.com  
**Jimmy Emerson** (207) 483-6555 jemerson@friendshiptrap.com  
**Mike Wadsworth** (207) 542-0841 mikew@friendshiptrap.com

**Friendship Office:** (800) 451-1200; (207) 354-2545

**Columbia Falls Office:** (800) 339-6558

**Visit our website:** [www.friendshiptrap.com](http://www.friendshiptrap.com)



## From the Executive Director's Desk



### ASMFC 80<sup>th</sup> Annual Meeting in Review

In November, Commissioners, proxies, federal partners, and stakeholders gathered at our 80<sup>th</sup> Annual Meeting in Long Branch, New Jersey, for the first time since the beginning of the pandemic. The meeting gave us the opportunity to make important decisions regarding the management of several key species, as well as celebrate the accomplishments of a great many individuals.

#### *Atlantic Striped Bass*

The Atlantic Striped Bass Management Board received the results of the 2022 Stock Assessment Update, which finds that management measures put in place through Addendum VI and Amendment 7 are beginning to take effect with the stock no longer experiencing overfishing. While the species is still overfished, spawning stock biomass (SSB) is slowly increasing due to a number of above average year-classes that continue to grow, mature, and contribute to SSB. The update also included short-term projections to determine the probability of SSB being at or above the SSB target by 2029, which is the stock rebuilding deadline. Under the current fishing mortality rate, there is a 78.6% chance the stock will be rebuilt by 2029. Given this, the Board decided a reduction in catch was not necessary at this time.

#### *Atlantic Menhaden*

Given the positive results of 2022 Atlantic Menhaden Stock Assessment Update, which found the resource is not overfished nor experiencing overfishing relative to the current ecological reference points (ERPs), the Atlantic Menhaden Management Board set the 2023-2025 total allowable catch (TAC) at 233,550 mt, an approximate 20% increase from the 2021-2022 TAC. This modest increase in TAC provides the states with additional fishing opportunities, while maintaining a conservative risk level within the bounds of the ERPs. Additionally, the Board approved Addendum I to Amendment 3 to the Interstate Fishery Management Plan. The Addendum makes a number of changes to the management program to balance historical landings with an increased demand for bait given the recent expansion of the species into the Northeast.

#### *Horseshoe Crab*

The Horseshoe Crab Management Board met to set harvest specifications for horseshoe crabs of Delaware Bay-origin. Maintaining its conservative management program, the Board set a harvest limit of 475,000 male and zero female Delaware Bay horseshoe crabs for the 2023 season. In making its decision, the Board considered the recommendations of the recently revised Adaptive Resource Management (ARM) Framework and the extensive public comment it received regarding concern about the status of the red knot population in the region and the harvest of female horseshoe crabs. The Board also unanimously approved Addendum VIII, which adopts the changes to the ARM

Framework as recommended in the peer-reviewed 2021 ARM Framework Revision, and allows its use in setting annual bait harvest specifications for horseshoe crabs of Delaware Bay-origin. The ARM Framework Revision is a considerable advancement in the science upon which horseshoe crabs are managed in the Delaware Bay Region. It represents years of effort by both fishery scientists and shorebird experts to improve the model and data inputs for both species to ensure that ecosystem needs are adequately addressed.

#### *Honoring Accomplishments*

In addition to these positive assessment and management outcomes, we also were able to recognize the efforts and accomplishments of a great many people who help to improve the lives of fishing communities and contribute to our larger effort of sustainably managing the resources under our care. Over the past two years, CARES Act administrators in each state's marine fishery agencies distributed over \$200 million to thousands of people in the aquaculture, for-hire, and commercial fishing industries that suffered from the loss of opportunities and income during the pandemic. At the Annual Meeting, we were able to recognize all those involved in this effort that was made possible by funding provided by Congress and administrative assistance from NOAA Fisheries and the Commission's Finance Department.

We were also able to recognize the outstanding contributions of two of our Commissioners – Douglas Grout of New Hampshire and Dr. Jason McNamee of Rhode Island – to the conservation and management of Atlantic coast fisheries resources by presenting them the Captain David H. Hart Awards for 2020 and 2022, respectively. Their collective efforts represent decades of work to improve not only our management actions and policies but the science upon which we base our actions. It was a wonderful way for us to celebrate our first Annual Meeting together since 2019 by honoring these two worthy individuals.

#### *Staff Transition*

Over the past several months, the Commission has experienced a number of staff transitions as people have moved on to advance their careers and pursue new opportunities. We are grateful for all their hard work to better our management, science, and data collection efforts and wish them the very best in their new endeavors. While we are sad about their departures, we are excited about the new people who have come (and will come) to fill their positions, bringing new perspectives and energy to the Commission.

Lastly, I wish you all a very happy and healthy holiday season. Best wishes and thanks for the fishes.

Our inventory is a unique mix of traditional and the latest in marine technology, representing a wide range of top marine manufacturers. We're the one-stop destination for all things boating and beyond.

*Happy New Year!*



800-639-2715



hamiltonmarine.com

KITTERY • PORTLAND • ROCKLAND • SEARSPORT • SW HARBOR • JONESPORT • MAINE

## FISHING PARTNERSHIP



SUPPORT SERVICES

### NAVIGATOR OFFICES



Gloucester  
978-282-4847



New Bedford  
508-991-3043



Plymouth  
508-746-5400



Chatham  
774-840-9393

## Connecting You to Massachusetts Health Insurance Year-Round

**2023 Open Enrollment**  
Nov. 1, 2022 - Jan. 23, 2023

Fishing Partnership Navigators can help any MA resident under 65 access health insurance. A Navigator can assist you with applying for coverage, renewing your plan, making changes to your application, or shopping for a new plan.

*Contact a Navigator anytime during the year to apply or make changes to your application.*

*Apply by Jan. 23 to have coverage that begins Feb. 1.*

Massachusetts maintains a mandate for all individuals to have health insurance. Unenrolled residents could pay a tax penalty. Don't risk it - call a Navigator and get covered today!

Scan to Request Health Insurance Services



617-928-3443  
fishingpartnership.org



Visit MAHEALTHCONNECTOR.ORG for more information





# Legal Defense Fund Updates

The Massachusetts Lobstermen's Association (MLA) Legal Defense Fund (LDF) needs your support now more than ever. This dedicated fund is for the purpose of defending the Massachusetts commercial lobster fishermen from legal and fisheries management actions that could seriously impact our commercial lobstermen's ability to conduct their businesses and earn a living.

Currently, the MLA is actively engaged in three separate lawsuits that could have negative impacts on the commercial lobster industry and is working with multiple lawyers in Washington D.C. and here in the Commonwealth to fight for you and your industry.

## UPDATE DECEMBER 30, 2022 — Omnibus Bill:

The recent Omnibus Bill passed by Congress and signed by President Biden contained crucial language inserted by Senate Majority Leader Chuck Schumer (D-N.Y.) and Senator Patrick Leahy (D-Vt.) for the future of the lobster industry. While our lawyers are still parsing through the language to prepare a detailed summary of its effects, the important language seems to provide that the lobster industry can continue to operate using its current technologies and techniques through December 31, 2028.

The relevant language from the Omnibus Bill is below:

DIVISION JJ—NORTH ATLANTIC RIGHT WHALES TITLE I—NORTH ATLANTIC RIGHT WHALES AND REGULATIONS SEC. 101. NORTH ATLANTIC RIGHT WHALES AND REGULATIONS. (a) IN GENERAL.—Notwithstanding any other provision of law except as provided in subsection (b), for the period beginning on the date of enactment of this Act and ending on December 31, 2028, the Final Rule amending the regulations implementing the Atlantic Large Whale Take Reduction Plan (86 Fed. Reg. 51970) shall be deemed sufficient to ensure that the continued Federal and State authorizations of the American lobster and Jonah crab fisheries are in full compliance with the Marine Mammal Protection Act of 1972 (16 U.S.C. 1361 et seq.) and the Endangered Species Act of 1973 (16 U.S.C. 1531 et seq.). The National Marine Fisheries Service shall— (1) throughout the period described in the preceding sentence, in consultation with affected States and fishing industry participants,

promote the innovation and adoption of gear technologies in the fisheries described in the preceding sentence, in order to implement additional whale protection measures by December 31, 2028; (2) promulgate new regulations for the American lobster and Jonah crab fisheries consistent with the Marine Mammal Protection Act of 1972 (16 U.S.C. 1361 et seq.) and the Endangered Species Act of 1973 (16 U.S.C. 1531 et seq.) that take effect by December 31, 2028, utilizing existing and innovative gear technologies, as appropriate; and (3) in consultation with affected States, submit an annual report to Congress on the status of North Atlantic Right Whales, the actions taken and plans to implement measures expected to not exceed Potential Biological Removal by December 31, 2028, the amount of serious injury and mortality by fishery and country, and the proportion of the American 19 lobster and Jonah crab fisheries that have transitioned to innovative gear technologies that reduce harm to the North Atlantic Right Whale. (b) EXCEPTION.—The provisions of subsection (a) shall not apply to an existing emergency rule, or any action taken to extend or make final an emergency rule that is in place on the date of enactment of this Act, affecting lobster and Jonah crab.

This is a big reason to celebrate! However, we do anticipate a flurry of litigation by environmental groups to try to weaken this language. This might also affect the current litigation summarized below. Finally, it is not clear how NMFS will interpret this language but we are fully prepared to continue the fight to protect the lobster industry and ensure that our cutting-edge efforts and sacrifices to protect the Right Whale earn the recognition they deserve.

**UPDATE DECEMBER 30, 2022 —** (Washington D.C.) Case 1:18-cv-00112-JEB - CENTER FOR BIOLOGICAL DIVERSITY et al v. ROSS et al, the Plaintiffs requested that the Court issue an order:

1. Declaring that NMFS violated the ESA and APA for issuing an ITS in the 2021 BiOp for zero lethal right whale take in the federal fishery without first authorizing incidental take under the MMPA, 16 U.S.C. § 1371(a)(5)(E);
2. Declaring that NMFS violated the ESA and APA by anticipating but not authorizing lethal take in the federal lobster fishery in the 2021 BiOp ITS;

3. Declaring that NMFS violated the MMPA and APA in issuing a final rule amending the Plan that failed to contain the measures the agency expected would reduce right whale M/SI in the U.S. lobster fishery in both state and federal waters to below PBR within six months of implementation;

4. Vacating and remanding the 2021 BiOp with respect to the right whale and the federal lobster fishery with vacatur stayed for six months and ordering NMFS to produce a new biological opinion that includes fully complies with the requirements of the MMPA and ESA in authorizing any anticipated lethal take of right whales in the federal lobster fishery; and

5. Remanding without vacating the Final Rule and ordering NMFS to issue a new rule within six months of the order that contains the measures NMFS expects will reduce right whale M/SI in the U.S. lobster fishery to below PBR within six months of the rule's implementation.

While we obviously do not agree with their analysis, science, and most of what they seek (including their apparent opposition to weak rope and intent to push the industry into ropeless fishing), **we are encouraged by the fact that we (and others) were able to persuade the NGO's to not seek a restraining order concerning our lobstermen's ability to fish even if the Court vacates and remands the 2021 BiOp and orders NMFS to produce a new biological opinion.** that, in the Plaintiffs or in the Court's view, fully complies with the requirements of the MMPA and ESA. As it now stands, the CBD Plaintiffs request that, if the Court vacates and remands the 2021 BiOp and orders NMFS to produce a new BiOp and Final Rule, our fishermen be able to continue to fish as-is for at least 6 months post Court decision and until NMFS fashions a new BiOp and new Final Rule.

NMFS's remedy brief (limited to 30 pages) was filed on September 19, 2022. In its briefing, NMFS proposed the Court set a date of **December 9, 2024**, for it to issue a TRP amendment remedying the deficiencies in its. As part of this proposal, NMFS also requested that the 2021 BiOp be remanded without vacatur through to December 9, 2024.

NMFS noted the extreme difficulty it would

# LDF Updates

FROM PAGE 39

have in meeting Plaintiff's proposed six-month deadline and explained that it would need to take in additional research and data, including on death dispersions from Canada and the US, to make a proper ITS. This is encouraging to see, as the Court recently determined that NFMS's method for assigning deaths between Canada and the US was reasonable (although we strongly disagree).

However, a large part of NMFS's proposed remedy was focused on implementing and advocating a migration away from VBR which is of course untenable for the vast majority of our members.

We submitted our Remedy Brief on October 7, 2022. In our brief we requested that the Court remand without vacatur, so as to keep the Biological Opinion in place while NMFS issues a new regulation. We also requested that the Court not set a hard deadline for NMFS to finish, but rather to require 6-month status updates to give NMFS the time it needs to do this right. Interestingly, the other Intervenor Defendants adopted our strategy, requesting 6 month status updates.

Plaintiff's Reply Brief was filed on October 21, 2022.

All these are on MLAs website home page under the Right Whale Litigation and Management updates.

On November 10, 2022, the remedy hearing was held. It is uncertain what the Court intends to do at this stage, but we are pleased that Maine and the other lobster organizations specifically said they were adopting the position laid out in MLA's briefing and noted that MLA had the right idea first. What's more, the government adopted some of MLA's positions as well.

That being said, the Court laid out three options that it might proceed with:

1. **Vacate the Biological Opinion but stay vacatur indefinitely.** This was the Court's proposal which it seemed to be presenting as a middle ground but was opposed by all lobster parties as the lobster industry would constantly be at risk of being shut down at any moment. The government was also strongly opposed to this position because it did not think it could get a viable biological opinion done by 2024 that was no jeopardy, while the NGOs unsurprisingly complained that this wasn't sufficient to protect the whales

2. **Vacate the Biological Opinion but stay vacatur until December 2024.** This was the

NGOs' proposal, which would functionally allow the lobster industry to operate until December 2024 but would in reality cause many to decide to leave the business given that the loss of the BiOp would make lobstering impossible.

3. **Remand without vacatur.** This one was really presented in two possible ways:

a. Our proposal, adopted by Maine and Maine Lobstermen's Association, was to remand without vacatur with 6-month status updates so that the lobster industry could continue while a new BiOp was being developed without the risk of it suddenly being shut down.

b. Maine Lobstering Union modified our proposal slightly, proposing to remand with the decision on vacatur stayed for 18 months so the Court could determine based on status updates whether to vacate or not.

On November 17, 2022, the Court issued its order, granting the lobster industry a massive win! Adopting the Massachusetts Lobstermen Association's position, the Court remanded **without vacatur, staying a decision on vacatur until December 2024. Further, the Court set a deadline of December 9, 2024, to issue a final order, but did not set a hard deadline for a new Biological Opinion. Instead, it required NMFS to issue status updates every six months starting on July 10, 2023, so that the Court could track NMFS's progress in creating a new Biological Opinion.**

**While it remains to be seen, we believe that the language of the Omnibus Bill (above) compels Judge Boasberg to stay any decision on vacatur until December 31, 2028. In other words, instead of the December 9, 2024 date dictated by Judge Boasberg, the legislature dictated that the deadline should be December 31, 2028.**

**UPDATE DECEMBER 30, 2022** — (D.C.) Maine Lobstermen's Association, et al. v. NFMS

**ORDER GRANTING SUMMARY JUDGMENT** - Judge Boasberg has issued his summary judgment order in MLA v. NMFS ruling against the Maine Lobstermen's Association (and us) on every single ground we raised challenging the 2021 BiOp. This is a very disappointing order that we appealed to the D.C. Circuit. In his Order, Judge Boasberg did the following:

1. The Court then found that several grounds raised by the Maine Lobstermen's Association should have been brought in the complaint and, because they were not, the Court would not consider them. This includes the following arguments: (Opinion at 11)

a. Regularly Flexibility Act

b. MMPA's purposes

c. Composition of the take-reduction team

2. Turning to the challenges to the BiOp itself, the Court first ruled as a general matter that NFMS applied the "best scientific and commercial data available", meaning that challenges to NFMS' scientific determinations were not going to succeed. It made this ruling on the basis that data was limited and the agency made valid determinations within the range of scientific judgment

a. As part of this conclusion, the Court dismissed the argument that the NFMS' Consultation Handbook required different scientific analysis by determining that it only requires using the best scientific, which the Court believed NFMS used

3. We then arrive at the more specific claims that was raised against NFMS

a. US/Canada Allocation: The Court determined that the data about where deaths were occurring was uncertain so it was fair for NFMS to use a 50/50 split, especially when the Center for Independent Experts determined the approach was "reasonable".

b. Unknown Origin Entanglement: The Court determined that the unknown origin death data was limited and that it wasn't unreasonable to attribute it to gillnet fishing and VBR especially since deaths seem to happen in VBR areas.

c. Cryptic Mortality: The Court determined that NFMS used a "rigorous peer reviewed method" developed by whale researchers to determine where deaths occurred and that the fact that whales migrate doesn't affect this.

i. The court also determined that natural mortality challenge was adequately explained by NFMS as mostly occurring to whale calves so adult deaths are likely caused by humans.

d. The Court also wholly rejected any reliance on harm mitigation methods deployed by MLA because NFMS did not have access to data on the mitigation measures but incorporated the effects into its modeling as best it could

e. Finally, the Court determined that NFMS could use the "Linden model" and the Decision Support Tool because they are peer-reviewed and thus constitute best date

4. The Court rejected the argument that NFMS attributed too many deaths to the lobster industry, explaining that NFMS had to fall below the PBR because it was just one part of many government agencies impacting whale populations and thus could overestimate the harm



5. Having found that the BiOp survives the challenges against it, the Court then said that the Final Rule also survived because the only challenge to it was that the BiOp was invalid

At the end of its Order, the Court did note that it “fully expects that NMFS will continue diligently incorporating the latest information, considering the concerns of all stakeholders, and adapting to changing circumstances in making its future decisions”. (Order at 33).

We disagree with the Court on each of the grounds it found and will vigorously challenge them on appeal.

For the Appeal, the D.C. Circuit set a briefing schedule where Appellant (meaning Maine Lobstermen’s Association) and Appellant-Intervenor (meaning us, the Maine Lobstering Union, and the State of Maine) briefs are due on November 9, 2022. The D.C. Circuit originally only granted the Appellant-Intervenors two briefs between the three of them, with a total word limit of 9,100. After briefing, we now get our own brief of 4,050 word limits, MLU gets its own brief of 4,050 words, and the State of Maine get its own brief of 6,000 words.

Our brief informed the Court about the importance of the lobstering industry to Massachusetts and focused on the clearly erroneous data used by NMFS and pointing out to the D.C. Circuit that the law requires NMFS to use the best evidence available, which they failed to meet.

The State of New Hampshire also joined in the briefing with an amicus (“friend of the court”) brief, explaining the impact of NMFS’s regulations on the State of New Hampshire, and the Maine State Chamber of Commerce has submitted an amicus brief as well, explaining the economic impact on the lobster industry in Maine.

All these are on MLAs website home page under the Right Whale Litigation and Management updates.

Appellees (meaning NMFS) and Appellee-Intervenors (the NGOs) filed their opposition briefs on December 20, 2022. NMFS and the Center for Biological Diversity submitted their appellate briefs on time, with the government mostly repeating its arguments below that it was allowed to rely on its flawed or non-existent science as the best available science, while also arguing that it did not use flawed or non-existent science. The Center for Biological Diversity’s appellate brief mostly focused on arguments about the importance of the Right Whale and parroting the government’s arguments regarding its science.

The Appellants (including, the MLA’s) Reply Briefs are due on January 10, 2023. The MLA’s brief is limited to 2,500 words.

While we are unsure, we anticipate that the Government and the NGO’s will move to dismiss the appeal as moot because of the above quoted language in the Omnibus Bill. While we are still considering strategy, we would most likely argue that the appeal is not moot and is ripe because the Omnibus Bill is intended to give us time to address underlying flaws in the Government’s science (i.e. including issues with cryptic mortality, allocation of mortalities to the fisheries, allocation of mortality between the United States and Canada, etc.), point out the harm by seasonal closures, and attack the 90% Potential Biological Removal requirement which flows from the flawed science.

The commercial lobstermen’s businesses are at stake as well as the thousands of jobs and shore side businesses that depend upon the continued success of the commercial lobster industry. The commercial lobstermen in Massachusetts are NOT to the problem and have done everything asked of them by National Marine Fisheries Service and have been working under the strictest conservation rules for the right whales anywhere in the world since 2014. Yet here we are, still fighting these lawsuits to keep the Massachusetts commercial lobstermen fishing.

The Massachusetts Lobstermen’s Association has been actively involved in these lawsuits since 2018 and we need your generous support today to continue our fight to keep the commercial lobstermen fishing. As we all know, any legal action costs lots of money and over the last 5 years the Massachusetts Lobstermen’s Association Legal Defense Fund has spent over \$300,000 fighting these legal battles. These are real threats to the historic and iconic commercial lobster industry and we are doing everything to keep the Massachusetts commercial lobstermen fishing.

#### WHERE TO MAKE DONATIONS

Any contribution you can afford to make to the Legal Defense Fund is greatly appreciated.

#### Donate by mail:

MLA LDF,  
8 Otis Place  
Scituate, MA 02066

#### Donate online:

[www.lobstermen.com](http://www.lobstermen.com)

– In the Members section select Dues/Donate.



# DONATE TODAY!

to the Massachusetts Lobstermen’s Association

## LEGAL DEFENSE FUND

### JANUARY 2023 SUPPORTERS

James Bartlett

Jeff Bartlett

Edward Desrosier

Eckland & Blando LLC

Robert Hannah

Steve Holler

Peter Krzyzewski

Peter Vincent Libro

Eric Lorentzen

James Moleti

Scott Rowe

Therese Sauvageau

**THANK YOU FOR YOUR CONTINUED SUPPORT!**

# MLA Classifieds

Classified ads are a free benefit to MLA Members and Non-members are a flat \$25.00. Ads run for 5 months & will be automatically deleted unless you call the MLA office to renew.

**781-545-6984** or email ads to: [tracey.abboud@lobstermen.com](mailto:tracey.abboud@lobstermen.com)

*\*All ads are subject to review prior to placement*

AD #1 (10/22) **FOR SALE** – Area 1 Coastal Lobster Permit Call 508-824-0177.

AD#2 (9/22) **FOR SALE** – Trap Trailer 6x12 can hold approx. 50-3 footers. Good shape. \$1,200.00 Call Ben@ 978-578-8882.

AD#3 (10/22) **FOR SALE** – Hydraulic Components, parts and service. Pumps, Motors, Valves and Accessories. Hydraulic Hoses made while you wait. Great Prices– Same day service (in many cases)-Wide selection of in-stock items. Rebuilt items occasionally available. ROSE MARINE, Gloucester, MA 877-283-3334.

AD#4 (10/22) **FOR SALE** – 800 lobster pots 36 x 22 1/2 x 15 5 years old -new -all ground lines included. 10 pot trawls- all spliced. 3-brick in every pot-haul from starboard & kitchen. 10-12 gauge wire. Dick @ 774-218-4701 for more details.

AD#5 (9/22) **FOR SALE** – 24 Crosley net lift \$2,000.00, 15 ft. of 7 1/2 inch mooring chain \$50.00. 20lb. 3/4 stainless steel hog rings B.R.O. 20lb. 1/2 hog rings. 2 – 55 gallon barrels of 7/16th ground line B.R.O. 10-white pingers \$25.00 each Used Gillnets foam and standup B.R.O. Text Only 617-694-4802.

AD#6 (9/22) **FOR SALE** – Marine-land 55 gal Live Lobster Tank \$690.00 John @617-750-3263.

AD#7 (8/22) **FOR SALE** – Cold water dive suit w/all accessories-used once-still in boxes.\$2,000.00 Robert 617-240-5196.

AD#8 (9/22) **FOR SALE** – 38 ft Novi fiberglass over wood- John Deere 6068. 225hp 5,670 hours on Engine-Steamers @8.5/9 knots 14 hauler Simrad Autopilot Inside/Outside steering stations- 150 gal fuel tank- Lobster tank holds 600lbs. Furuno GP-39 S inside-Furuno GP- 32 GPS outside- Furuno Radar, Furuno FCV-292 color video sounder-2VHF. Inside/Outside 2 computer monitors, one face inside- other faces outside steering station. Very quiet engine. Asking \$15,000.00 Call- 978-290-9929.

AD#9 (11/22) **FOR SALE** – 35 lobster boat McPherson built of wood in Nova Scotia in 1976 – glassed over approx. 8 years ago, repowered w/ 1991 120 hp 6cyl Mitsubishi goes up to 9 knot on 11/2 gal/hr new exhaust & auto-pilot 2 years ago. Trap ramp, bunks, electronics ect. Boat currently fishing-will be available for purchase December 16th \$25,000 -Call (508) 939-1231.

AD#10 (11/22) **WANT TO BUY** – Used insulated tubs with lids. mrfish@mrfish.com or Ted 843-267-3473.

AD#11 (10/22) **FOR SALE** - Warp–Used & some new, mostly knot free. 76 lbs. 5/16, 33 lbs. 3/18 \$99 takes all 508-269-1406 Plymouth.

AD#12 (10/22) **FOR SALE** – 18 Wooden Lapstreak Skiff. In remarkable condition. Bottom was fiber-glassed before first used. All heavy duty oak ribs, stiffeners, ribs & floor cleats. Excellent boat for coastal/harbor fishing, or for lugging traps. Will send picture upon request. \$1,990.00 or BRO. 508 269-1406.

AD#13 (1/23) **FOR SALE** – 35 foot fiberglass Novi Lobster boat. 210 Cummins 6BT with 4400 hours. 2.57:1 72C series velvet drive. 14" hauler. Furuno sounder, Furuno GPS, ICOM VHF, Standard Horizon VHF, Garmin Radar with plotter, AIS Receiver interfaced to Computer with mapping software. Currently fishing. \$32,000 or best reasonable offer. Boat available after January 30, 2023. Active Massachusetts commercial lobster permit available. Federal area 1 lobster trap permit available. 400 traps with rope and buoys available. Call Bob 508 284 5896

AD#14 (11/22) **WANTED** – Double drum winch-45ft Boat-Call 978-283-2550.

AD#15 (9/22) **FOR SALE** – 12" Electra-dyne hauler & davit. \$1,800.00 John @ 617-750-3263.

AD#16 (9/22) **FOR SALE** – Fiberglass mold/Swampscott style square bow 10 ft. flat bottom work skiff \$950.00 Call- 978-578-8882.

AD#17 (12/22) **FOR SALE** – 200 used traps 13 1/2 x 21 1/2 x 39 \$25.00 per trap. Call 401-635-4371

AD#18 (10/22) **FOR SALE** – 24' Privateer, 5.7L Crusader low hours, Honda hydraulic power pack with 10" hauler. S.S. Davit. Plotter, sounder, radar, VHF. New cockpit floor & deck with 2' stern extension. Rigged for pot hauling. Ready to fish. \$16,000. Area 2 coastal Mass lobster permit, 90 pot allocation \$25,000. Selling as a package, boat & permit \$35,000. Located in Oak Bluffs. 774-563-0393.

AD#19 (8/22) **FOR SALE** – 200-LMA 2 EEZ/ inshore dual zone trap tags \$27,000 Call - 508-542-5729.

AD#20 (11/22) **FOR SALE** – 1,000 hooks new tub trawl-gear W/anchors, 180 buoy lines. B.R.O. Bryan @ 508-221-8568.

AD#21 (11/22) **FOR SALE** – 1987 Daniels Head 39' 11" Fiberglass Gillnet boat. 207HP Mitsubishi D14.14 T Diesel engine (1992), Twin Disc 506 trans, complete electronics, 2 berth, 6'x5' aluminum gill net reel with stainless

frame, 2 fish holds, 2 insulated deck boxes, rollers, 2 bus heaters, vessel in good condition – new fuel tank, new paint/fiberglass/fish boxes (2022). \$79,500 or B.R.O. Fed Permit Monkfish B with around 80 nets and 16 dog nets with buoy st anchors \$45,000. Federal directed shark permit \$15,000. - Call 609-294-1628 /text for pictures 609-713-5228 .

AD#22 (10/22) **FOR SALE** – Area 1 lobster permit, 800 pots-\$25,000.00 B.R.O. Call 774-283-2191.

AD#23 (8/22) **FOR SALE** – 100 traps 36x21x15 \$10.00 each Life Raft \$500.00 Call- 508-577-4868.

AD#24 (8/22) **FOR SALE** – LMA-1 Federal lobster permit, 800 trap allocation, good history \$38,000.00 978-578-8882.

AD#25 (9/22) **LINE FOR SALE** – 3-10 pot trawls of 7/16" Everson line-14 Fathom between traps-7/16" gangions-2 – 20 F x3/8 "buoy lines-In totes included -\$60.00 / trawl Joel @ 781 581 0324 or E-mail [joel.w.marie@gmail.com](mailto:joel.w.marie@gmail.com).

AD#26 (9/22) **FOR SALE** – 5" Superior hauling block-Aluminum construction with stainless sheave \$250.00 Joel @ 781 581 0324 or E-mail [joel.w.marie@gmail.com](mailto:joel.w.marie@gmail.com).

AD#27 (9/22) **FOR SALE** – Spare new stainless sheave for 5" Superior block-\$150.00 Joel @ 781-581-0324 or E-mail [joel.w.marie@gmail.com](mailto:joel.w.marie@gmail.com).

AD#28 (12/22) **FOR SALE** – two aluminum propellers 13.5x15 & 14x11 for Evinrude outboard were on 115 HP, great condition \$50. each Ipswich 978-356-4525.

AD#29 (9/22) **FOR SALE** – Area 2 lobster permit 128 tag limit \$21,000.00 774-775-2827.

AD#30 (9/22) **FOR SALE** – 22ft. Siso Lobster boat 150HP Evinrude OB needs work has 12" hydraulics hauler runs off Honda hydraulics power pack needs work & comes with trailer. Asking \$13,000.00 or B.O. Robert @ 5:00p.m. 617-846-3714 or 617-650-3842.

AD#31 (9/22) **FOR SALE** – #1 Bellhousing 2:1 gear reduction – re-built 51 14A – twin disc transmission – Down Angle-North Atlantic Power Products. 0- hours. 1000 hours or 6-months warranty, \$17,200.00 Peter @ 203-627-6070.

AD#32 (10/22) **FOR SALE** – Lobster Boat-1968 Novi fiber glassed over wood. John Deere 2011 Call for more info-978-290-9929 \$13,500.00.

AD#33 (12/22) **FOR SALE** – Mass conch license \$40,000 Call 508 496 5626

AD#34 (12/22) **FOR SALE** – 28.2ft boat, built in 1976 engine cat 3208, 265HP trans 2.1 twin disk fiberglass JC hull. Area 1 Coastal lobster permit 800 traps, 700 3ft lobster traps with rope and buoys. Call Joe 978-239-5927.

AD#35 (12/22) **FOR SALE** – 36.5' Wayne Beal Lobster Boat. 3208 CAT 375 hp Turbo w/7600hrs. Motor was completely overhauled prior to 2022 fishing season. Furuno chart plotter, depth, radar & radio. 2nd Simrad below. Switlik life raft, survival suits & Epirb. Small galley w/sink, insulated icebox & 2500 watt inverter for coffee. 4 bunks w/mattresses. Working head. Pacer pump & separate washdown pump. Redundant spare equipment (all new in box), Inc. Pacer pump w/hydraulic hoses, belts, starter motor, 2 alternators, windshield wiper arms & motors, bilge pumps, deck hoses, etc. Boat in clean & in excellent, fishable condition. \$215,000.00 Traps & Permits available. Ben @ 978-578-8882

AD#36 (12/22) **FOR SALE** – 100 brand new, standard size heavy waxed fish boxes w/ tops. Foot operated box stapler w/staples, air operated Bostitch carton stapler w/ staples \$200.00. Inshore Longline/Tub trawl gear 1000 + hooks [over a mile] rigged w/ gangions and clips, new ground lines, extra snaps, boxes of brand-new Mustad Easy Baiter hooks. Ready for codfish, dogfish, bluefish. "Chatham/Jamestown" auto baiter (3-4 bushel size) Gillnets: (12) 12 " Monkfish (w/tie downs) most brand new, some recent rehangs, other assorted sizes. Lots of floats, lead line, net frames to be re –hung. Lots more fishing gear. Too much to list, ALL PRICED TO SELL. Call for your needs. Located in Freeport, Long Island, New York Call, text or E-Mail. Leave your name and phone number. I will CALL you in the evening after 6 PM. Capt. Rich. 347-836-5382, e-mail captrichunt@aol.com

AD#37 (12/22) **FOR SALE** – Lobster business-42 ft PEI lobster boat in excellent condition. Relatively new Cummins 6 CTA 8.3 engine & ZF gear. Full electronics. All safety gear. Below deck 2500 lb plus tank. Too many details to list here. 700 very good Brooks Mill traps. Knotless ground lines in 20 pot trawls. All end lines & extensions, whale rule compliant. Hi-flyers & tide balls State & Federal Lobster licenses, both w/ 800 pot history & many federal endorsements. Selling as complete package only. \$273,500. Serious inquiries only Mike 978-745-6182 & leave a message.

AD#38 (1/23) **FOR SALE** – Area 1 Coastal Lobster Permit, 800 pot allocation. Call Jim 781-264-0104

AD#39 (1/23) **DECK TILES** – 1x2 ft. Old style – good shape looking for about 10 call 978 774 4074

# CAT MARINE ENGINES

## Tier 3 Commercial Line-up

### C7.1



#### C7.1 Tier 3 Commercial Ratings:

280 HP @ 2300 Heavy Duty "B" **IN STOCK**  
350 HP @ 2500 Maximum Continuous Duty "C" **IN STOCK**  
400 HP @ 2600 Intermittent Duty "D" **IN STOCK**  
425 HP @ 2700 Intermittent Duty "D" **IN STOCK**

### C9.3



#### C9.3 Tier 3 Commercial Ratings:

375 HP @ 1800 Heavy Duty "B"  
416 HP @ 2100 Maximum Continuous Duty "C"  
476 HP @ 2300 Intermittent Duty "D"

### C18



#### C18 Tier 3 Commercial Ratings:

470 HP @ 1800 Continuous Duty "A"  
600 HP @ 1800 Continuous Duty "A"  
670 HP @ 1800-2100 Heavy Duty "B"  
715 HP @ 1800-2100 Maximum Continuous Duty "C"  
803 HP @ 2100 Intermittent Duty "D"

#### \* Tier 4 Exempt Light Commercial Ratings:

**1,001 BHP @ 2300**  
**1,136 BHP @ 2300**

### C32



#### C32 Tier 3 Commercial Ratings:

750 BHP @ 1600-1800  
800 BHP @ 1600-1800

#### AUTHORIZED MARINE DEALERS

**Billings Diesel & Marine Service**

Stonington, ME

**Dennis' Welding & Marine**

Beals, ME

**Front Street Shipyard**

Belfast, ME

**Lyman Morse at Wafarer Marine Corporation**

Camden, ME

**Journey's End**

Rockland, ME

**Fairhaven Shipyard & Marina, Inc.**

Fairhaven, MA

**Guy Crudele Repair**

Gloucester, MA

**Sacchetti Marine and Industrial LLC**

Plymouth, MA

**Windward Power Systems**

Fairhaven, MA

**DePaul Diesel Services, Inc.**

Portsmouth, RI

**Hinckley Yacht Service**

Portsmouth, RI

**Rhode Island Engine Company, Inc.**

Narragansett, RI

\*All T4 Exempt Light Commercial Ratings, require qualifications review and approval by CAT Factory.

\*Contact Nick Fawle or Your Authorized Marine Dealer for Tier 4 exemption qualification details.

For Marine Engine Sales, contact Nick Fawle, our new Marine Market Manager.

**Nick Fawle at 603-484-5248**

Nick\_Fawle@miltoncat.com

**Milton**



miltoncat.com

Massachusetts Lobstermen's Association  
8 Otis Place  
Scituate, MA 02066

PRSR STD  
U.S. POSTAGE  
PAID  
Permit 137  
New England Newspapers, Inc.



**Stock and Custom-Built Traps  
Lobster and Specialty Traps  
Aquaculture Supplies  
Huge Inventory of Commercial  
Fishing Supplies  
Four Locations in Maine**



**BROOKSTRAPMILL.COM  
(800) 426-4526**