



# MASSACHUSETTS LOBSTERMEN'S ASSOCIATION

A LEADING Commercial Fishing Industry Association in New England



JOIN TODAY and  
show your support

DECEMBER 2022 NEWSPAPER • WWW.LOBSTERMEN.COM

# MLA WINS FAVORABLE RULING IN D.C. LAWSUIT



We are pleased to report that we finally received a win in the Center for Biological Diversity v. Ross litigation before Judge Boasberg. A copy of the Order can be found on the MLA's website [www.lobstermen.com](http://www.lobstermen.com) on the Right Whale Litigation Updates page.

The other counsels all agreed that this was the first significant win in this long-drawn-out fight. While we did not get everything we asked for, we nearly got there, and have managed to completely stave off shutdown (or further closures) for at least two more years, and likely preserved the right to beat it out right.

Here is a summary of what the Judge ordered:

1) He remanded the BiOp and Final Rule WITHOUT VACATUR, which means our members can continue to fish while a new BiOp is created by NMFS. (The Plaintiffs wanted remand of the Final Rule WITH VACATUR, which would have been a sword of Damocles over our membership's head);

2) He decided that the question of whether the 2021 BiOp should be vacated will be held in abeyance pending further briefing after issuance of a Final Rule by NMFS.



SERIOUS ABOUT SAFETY

LRSE.COM | 401-816-5400

590 FISH RD, TIVERTON, RI 02878  
 181 OLD COLONY AVE, UNIT A, BOSTON, MA 02127  
 55 STATE ST, NARRAGANSETT, RI 02882



SALES • SERVICE • TRAINING • RENTAL • OUTFITTING • PICKUP + DELIVERY

**Safety Equipment Servicing**

Life Raft + Survival Equipment has been selling and servicing all major brands of Life Rafts, EPIRBs/PLBs, Life Jackets, Immersion Suits, and Man Overboard Equipment since 1983.

We offer pickup and delivery to over 20 locations throughout the Northeast.

CALL FOR GREAT PRICING.

**North East Safety Training**

NEST, a division of LRSE, offers hands-on Basic, Advanced, and Customized Safety Training Courses, Monthly Drill Conducting, First Aid/CPR/AED Courses and Vessel Inspections.

VISIT OUR WEBSITE TO LEARN MORE.

-  **LIFE RAFTS**
-  **EPIRBs + PLBs**
-  **LIFE JACKETS**
-  **IMMERSION SUITS**
-  **MAN OVERBOARD**
-  **PICKUP + DELIVERY**

**COMMERCIAL LIFE RAFTS**

*Elliot, Zodiac, Crewsaver, Revere, Viking*



**FIBRELIGHT LADDERS**

*Man Overboard Recovery Cradle, Self Recovery Ladder*



**IMMERSION SUITS**

*Imperial*



**EPIRBs**

*ACR V4*



**FIRETKO®**

*Fire Suppression Tool*



**LIFE JACKETS**

*Mustang*



# MLA Sponsors

The following companies are proud supporting MLA members. We encourage our members to patronize them. If your company is not listed and you would like it to be, contact Tracey Abboud at 781-545-6984, ext. 2

**ALIVE & KICKING LOBSTER**  
LOUIS MASTRANGELO  
CAMBRIDGE, MA  
617.876.0451

**BAR HARBOR LOBSTER**  
JEFF HAZELL  
ORLANDO, FL  
407.851.4001

**BOSTON LOBSTER**  
NEIL ZARELLA  
617.464.1500  
bostonlobstercompany.com

**BOSTON SWORD & TUNA**  
STEPHEN SCOLA  
BOSTON, MA  
617.946.9850

**BROOKS TRAP MILL**  
STEPHEN BROOKS  
THOMASTON, ME  
207.354.8763  
stephen@brookstrapmill.com

**CAPE ANN MARINE**  
SALES & SERVICE  
978.283.0806  
CapeAnnMarina.com

**C-TRAP**  
MATT BORGES  
MATTAPOISETT, MA  
508.758.2740

**CAPE SEAFOODS**  
**BAIT DEALER**  
GERRY O'NEIL  
GLOUCESTER, MA  
978.479.4642

**CAPE FISHERMEN SUPPLY**  
DAVE LIBBY  
CHATHAM, MA  
508.945.3501

**CAPE TIP SEAFOODS**  
CHRIS KING  
PROVINCETOWN/ORLEANS  
508.487.0259 | 508.225.7221

**CAPTAIN MARDEN'S**  
**SEAFOODS**  
KIM MARDEN  
WELLESLEY, MA  
781.329.7007 | 781.329.0792  
captainmardens.com

**CHERRY ST. FISH MARKET**  
DARRYL PARKER  
DANVERS, MA  
978.777.3449

**CHRIS ELECTRONICS CORP.**  
FAIRHAVEN, MA  
508.994.8257

**COASTAL HYDRAULICS**  
RICH TUCKER  
SEABROOK, NH  
603.474.1914  
coastalhyd.com  
sales@coastalhyd.com

**COHASSET LOBSTER**  
**POUND**  
TOMMY ALIOTO  
COHASSET, MA  
781.383.1551

**EAST COAST SEAFOOD**  
SPIROS TOURKAKIS  
LYNN, MA  
781.593.1737

**ECKLAND & BLANDO**  
SAM BLATCHLEY  
BOSTON, MA 02110  
617.217.6936  
www.ecklandblando.com

**ELECTRA-DYNE CO INC.**  
JUDY MACCAFERRI  
PLYMOUTH, MA  
508.746.3270

**FARM CREDIT EAST**  
MIDDLEBORO, MA  
508.946.4455

**FISHER AIR FASTENERS**  
ED & CHRIS FISHER  
PEMBROKE, MA  
781.826.2522

**FISHERMEN SERVICES**  
DONNA CHEPREN  
781.545.5073 Ext. 16  
fishermenservices.com

**FLEET PROPELLER**  
**SERVICE**  
MIKE VALM  
FAIRHAVEN, MA  
508.979.8000

**FRIENDSHIP TRAP CO.**  
JERRY WADSWORTH  
FRIENDSHIP, ME  
800.451.1200

**HAMILTON MARINE INC.**  
56 US ROUTE 1 BYPASS  
KITTERY, ME 03904  
207.439.1133  
hamiltonmarine.com

**HARBOR FUELS**  
info@harborfuels.com  
617.720.3835

**HERCULES**  
JOHN REARDON  
NEW BEDFORD, MA  
508.993.0010

**JAMES HOOK & CO.**  
ED HOOK JR.  
BOSTON, MA  
617.423.5500

**JOHN M. KARBOTT**  
**CUSTOM**  
**WOODEN BOAT**  
**BUILDING & REPAIR**  
PLYMOUTH, MA  
508.224.3709  
by-the-sea.com/  
karbottboatbuilding

**KETCHAM TRAPS**  
HEATHER KETCHAM  
NEW BEDFORD, MA  
508.997.4787

**KINGFISHER TRAP**  
CARL HOWARD  
DENNIS, MA  
508.385.5968

**KING LOBSTERS**  
D.J. KING  
BRANFORD, CT  
203.488.6926

**KING MARINE LLC**  
CAPT. GEORDIE KING  
MARINE SURVEYOR  
207.337.8706  
kinggeordie@comcast.net

**LOBSTER CRUISES**  
PAUL QUINTAL  
PLYMOUTH, MA  
508.746.5342

**LOBSTER TRAP**  
**FISH MARKET**  
MONUMET BEACH, MA  
508.759.6400  
lobstertrap.com

**LOBSTER TRAP CO.**  
LOGAN CLARK  
BOURNE, MA  
508.759.4928  
lobstertrap.com

**LYNCH LOBSTER CO.**  
JOHN LYNCH  
BEVERLY, MA  
978.921.8088

**MAIN STREET WIRE**  
DOUGLAS, MA  
508.847.8888

**MARINE HYDRAULIC**  
**ENGINEERING**  
ROBERT CROWE  
ROCKLAND, ME  
207.594.9525 | 800.747.7550

**MILTON CAT**  
**POWER SYSTEMS**  
NICK FAWEL  
MILFORD, MA  
508.207.8542

**MORTILLARO LOBSTER,**  
**INC.**  
VINCE MORTILLARO  
GLOUCESTER, MA  
798.281.0959

**NAHANT FISH & LOBSTER**  
781.592.7500

**NAPA-CAPE COD**  
BILL DRINAN  
FALMOUTH, MA  
508-457-1734

**NAVROC MARINE**  
**ELECTRONICS**  
JASON PHILBROOK  
ROCKLAND, ME  
207.596.7803

**N.E. MARINE &**  
**INDUSTRIAL INC.**  
MIKE RICHARDSON (NH)  
603.436.2836 | 781.834.9301  
Info@newenglandmarine.com

**NEW ENGLAND PROPELLER**  
RON PECK  
PLYMOUTH, MA  
800.635.9504  
neprop@aol.com

**NORTH ATLANTIC**  
**POWER-TWIN DISC**  
SAM PROFIO  
EXETER, NH  
sprofio@glpower.com  
603.418.0470

**PIGEON COVE COOP**  
ROBERT MORRIS  
978.479.3828

**RFP LOBSTER BAIT**  
DICK PERENTZ  
774.248.0292

**RIVERDALE MILLS**  
NORTHBRIDGE, MA  
508.234.8715

**ROSES MARINE**  
MARTY BOLCOME  
GLOUCESTER, MA  
877.283.3334  
rosesmarine.com

**SEA CLIFF LOBSTER**  
FRANK COLLINS  
MANOMET, MA  
508.224.5700

**SPURS MARINE MFG.**  
PABLO SOSA  
FORT LAUDERDALE, FL  
800.824.5372

**SUPERIOR LOBSTER**  
MARSHFIELD-SANDWICH  
774.773.5048  
www.superiorlobster.com

**THE NEW RESULT**  
LOUIS LARSEN  
Mvseafood@vineyard.net

**TWO COUSINS**  
**FISH MARKET**  
BRIAN O'DONOHUE  
FREEPORT, NY  
516.379.5065

**WELLFLEET**  
**SHELLFISH CO.**  
508.255.5300  
sales@wellfleetshell.com

**WINDWARD POWER**  
**SYSTEMS**  
FAIRHAVEN, MA  
774.992.0059  
windwardpower.com

**WOOD'S SEAFOOD**  
JAY KIMBALL  
PLYMOUTH, MA  
508.746.0261  
www.woodseafood.com

**YANKEE FISHERMEN'S**  
**CO-OP**  
SEABROOK, NH  
603.474.9850

Make cleanup  
easy and fast.

# Blast Away!

Onboard Pressure Washers  
5.6 GPM @ 3,500 PSI

Our pressure washers  
come with everything you  
need, including 50' hose and  
wand with turbo nozzle.



Belt Driven

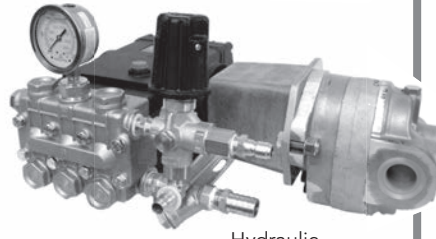

Hydraulic

Salt or Fresh Water

**Coastal Hydraulics, Inc.**

603-474-1914 • sales@coastalhyd.com  
www.coastalhyd.com  
28 Route 286, Seabrook, NH

## Steve's Rope Splicing

Custom Rope Splices

### BUOY LINE MARKING INSERTS

Massachusetts Vertical Line Solid Top Mark  
NOAA & DMF Approved  
20" Loop for easy attachment to buoy end  
\*Removable Green Federal Marking\*

**\$8**



1200' Spools of  
Red & Green  
3/8" Poly

**\$145**

**978-879-9737**

StevesRopeSplicing@Gmail.Com

Gloucester, MA



THE *Specialists*  
FROM BUOY TO TRAP

Built the Best, Built to Last,  
Built Your Way.

## PROVEN PERFORMERS! Rockbottom Runners



THEY MAKE  
THE BEST  
CRAB  
TRAPS  
TOO!!

Our precision formulation  
and process has been  
refined over the years  
to provide the optimum  
balance of strength and  
flexibility... – and the  
wise test shows it

Over **20 YEARS**  
of fishing;

Well over **HALF**  
**A MILLION** sold



Could you do this with  
any other concrete runner?

**Lite Load**

SOLID STEEL CORE  
- TOUGH POLYMER  
COATING



Over  
**6 YEARS**  
of fishing.

Over a **QUARTER**  
**MILLION** sold

**GORILLA WOOD**  
RUNNERS

OCEAN-TESTED for years...  
aircraft carrier decking and  
pilings in the marine borer  
intense Panama  
Canal Zone.



The toughest species  
of junglewood we've found  
... and the only kind we sell.

We are constantly listening to our customers:  
Your feedback + continuous improvement  
= proven reliability

### Here to serve you!

Jerry Wadsworth (207) 542-0842 jerryw@friendshiptrap.com

Jimmy Emerson (207) 483-6555 jemerson@friendshiptrap.com

Mike Wadsworth (207) 542-0841 mikew@friendshiptrap.com

Friendship Office: (800) 451-1200; (207) 354-2545

Columbia Falls Office: (800) 339-6558

Visit our website: [www.friendshiptrap.com](http://www.friendshiptrap.com)



Find us on:  
facebook



***Cape Seafoods Bait Shop  
Kicking off the Season!***



## **THE LARGEST BAIT VARIETY IN THE ATLANTIC NORTHEAST**

*In operation since 2001 and still going strong!*

**Trust Us for Your Fresh, Salted & Frozen Bait Needs**

**From (1) Carton to a Full Truck Load.**

**Herring, Mackerel, Pogies, Redfish, Rockfish, Tuna, Monkfish, Sardines,  
Plaice, Squid, Sea Robin, Halibut, & Silversides.**

**We've got you covered!**

**Great News...We now buy Lobster, too!**

**Open Year Round (Serving clients 7 Days a Week from Mid-June To Mid-October)**

**Monday-Friday 5AM-3PM, Saturday 6AM-12PM & Sunday 6AM-10AM**

**Main Phone Line: 978.283.8522**

**Bait Shop Phone Line : 978.479.4642**

***If we don't have it... Please ask and we'll find it!***

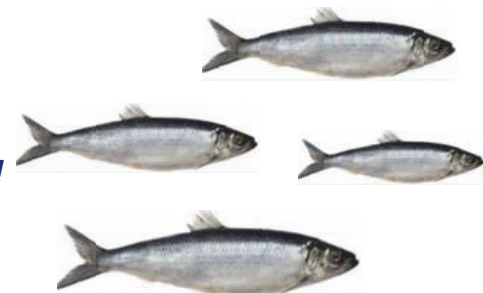



*Service Provider for MLA Non-Profit Boat Protection Cooperative Ltd.*

**MLA's #1 Commercial Boating Insurance Provider**

**Agreed Hull Value – Protection & Indemnity**

**Crew Coverage - Extended Policy Limits - Chartering**

**Marina Floaters - Multiple Fisheries - Deductibles**

**Call now for a free quote 781-545-5073**

**or**

**Request a quote online at [fishermenservices.com](http://fishermenservices.com)**



# As the HAULER TURNS

**The Massachusetts Lobstermen's Association** would like to welcome the following new members to the Association. Your Association will continue its efforts on your behalf to conserve the resource, protect your livelihood, keep you informed, promote the industry and provide you with increasing benefits as they are developed. MLA stands ready to help you in anyway, at anytime — just let us know how! Safe on the water and good fishing!

## NEW MLA MEMBERS:

### LARSEN FOYE

F/V: WhyKnot • Port: Kittery, ME



Published by the Massachusetts Lobstermen's Association, Inc.  
8 Otis Place, Scituate, MA 02066

– Published monthly –

Mailed to all paid members of the Massachusetts Lobstermen's Association

#### Newsletter Departments

Editor, Industry News, Notice Section, Editorial, Blog, Industry News, Promotions, Layout, Advertising:  
Beth Casoni — Executive Director

Buy Sell Swap: Tracey Abboud

#### Newsletter Advertising Rates

The MLA Newsletter is published monthly

(Please note that all pre-paid ads for last year will be honored)

\$50 — ¼ Page Ad

\$80 — ½ Page Ad

\$110 — Full Page Ad

Color Ads — + \$50 per ad



Here we are at the end of another year and what a year it has been! 2022 will definitely go down in the books as the year of litigation and tenacity. I do believe that the litigation that has slowed down, like molasses in January, and the tenacity of you all have is a true testament to your dedication to the commercial lobster industry. We are NOT going anywhere!

After the last several months of whale meetings and webinars it never ceases to amaze me how much time is literally spent “talking” about whales from birth to death. More is known about what, where and when these whales are than any other protected species and the hundreds of millions of dollars that is spent annually “talking” about them is mind bending.

Recently, the MLAs attorney, Sam Blatchley was successful in arguing the MLAs position in the CBD v. Ross case in the D.C. suit as Judge Bosberg’s ruling was favorable to the commercial lobster industry. The Judge ruled that NMFS would have to have the new rules implemented by December 9, 2024 and that the Biop will follow.

This is a win as the Judge could have shut it down until NMFS finished its Biop and Rule making which takes years. Please take the time to read this paper as there are several updates from the law-

yer on this. If you still have questions afterwards please call me.

Many of you have commented on this and are completely frustrated at the prospect of “more” risk reduction measures coming to the commercial lobster fishery. MA State waters is doing the most for the protection of whales and how everyone is asking, can MA give more when you are already at 85.5% risk reduced?

Furthermore, the DMF has been articulating to NMFS ALL of the risk reduction measures that were previously implemented of which no credit was given to MA. So far, it is looking like MA State waters will come out with about 90% risk reduction with little to no more risk reduction measures being needed.

Collectively, the federal waters in MA are another issue. Currently, MA federal waters are at about 31% risk reduced and they need to be upwards of 90% which leaves 59% more to go. Also on this front, the DMF was again articulating to NMFS that the initial credit given for the MA Restricted Area and then taken away by NMFS needs to be reinstated. This would give several many more points to the overall goal of achieving 90%. Every point matters!

Moreover, the ALWTRT met in November and went



through a slew of options for federal waters that could help achieve this goal and they ranged from; 400 trap cap, closure extensions, new closures (513- Zone G - Jeffery’s Ledge) and single endlines, 100% weak rope within 50fa, 75% within 100fa and more. More will be revealed as the ALWTRT will meet again on December 1st and 2nd to finalize what options will go out to Public Hearings this winter (2023).

If you have ANY questions, comments or concerns please feel free to call me or email me [beth.casoni@lobstermen.com](mailto:beth.casoni@lobstermen.com). Together, we will get through these tumultuous times. Massachusetts commercial lobstermen are “RockStars” in my eyes!

Safe on the water,

**Beth Casoni**

Director

# MLA Comments to DMF on Trap Fisheries, Mobile Gear Sessions & Whelk Gauge Sizes

November 7, 2022

Director Daniel McKiernan

Massachusetts Division of Marine Fisheries

251 Causeway Street, Boston, MA 02114

Via email to [marine.fish@mass.gov](mailto:marine.fish@mass.gov)



On behalf of its 1800 members, the Massachusetts Lobstermen's Association (MLA) respectfully submits this letter of comment on the proposed measures affecting the trap fisheries and the whelk gauge sizes as presented during the recent Public Hearing on November 3, 2022.

Established in 1963, the MLA is a member-driven organization that accepts and supports the interdependence of species conservation and the members' collective economic interests. The membership is comprised of fishermen from Maryland to Canada and encompasses a wide variety of gear types from fixed gear and mobile gear alike. The MLA continues to work conscientiously through the management process with the Division of Marine Fisheries (DMF), Atlantic States Marine Fisheries (ASMFC), Atlantic Large Whale Take Reduction Team, and the New England Fisheries Management Council to ensure the continued sustainability and profitability of the resources in which our commercial fishermen are engaged in.

## **ELECTRONIC TRACKING FOR COMMERCIAL LOBSTER & JONAH CRAB TRAP FISHERY**

The **MLA DOES NOT** support the vessel tracking initiative put forth by the ASMFC Addendum XXIX for the commercial lobster

and Jonah Crab industry as a management measure to better serve stock assessments, protected species interactions, marine spatial planning, and offshore enforcement.

Even though there is talk about financial help from the government on the startup funding for the lobster fleet, the MLA is concerned that the vessel tracking will be just another expense for the commercial lobster and Jonah Crab industry.

## **PROTECTED SPECIES REGULATIONS FOR COMMERCIAL AND RECREATIONAL TRAP FISHERIES**

The MLA **SUPPORTS** the adoption of a regulatory change to allow the Director of the DMF to temporarily amend the opening of the May 16-October 31 recreational trap fishery based on the presence or absence of right whales in state waters.

The MLA **SUPPORTS** eliminating the requirement that commercial trap buoy lines be rigged with a weak link at the buoy. Should a fisher choose to use one it will not be considered non-compliant.

The MLA does **NOT SUPPORT** the regulatory definition of the term "buoy line" as the proposed language allows the use of a groundline to the vertical line to be

no more than 12' seems unreasonable as many fishers' current are using a one third as a metric based upon the depth they are fishing. Using the average depth in state waters of 292', per the MA Ocean Planning document <https://www.mass.gov/files/2017-08/v2-text.pdf> and the one third metric would make the use of groundlines at 97', a far stretch from the proposed 12'. There needs to be more input from the industry on what a reasonable compromise would be as 12' is too short to avoid hang-ups.

The MLA understands the reasoning for this definition but does not see this as a one size fits all remedy. Could the State possibly do a range for groundline use like; 12' within 0-1nm, 24' within 1-2nm, 36' within 2-3nm to allow fishers in the deeper water the use more groundline?

## **WHELK MINIMUM GAUGE SIZE**

The MLA **SUPPORTS** the delay in the proposed gauge increase schedule for whelks by having 1/8" gauge increases occur every third year rather than the biennially until a terminal gauge size of 3 5/8" is reached.

## **ADDITIONAL GEAR MARKINGS PROPOSAL**

The MLA and Lobster Foundation of Massachusetts have been actively working on the incorpora-

tion of the *MASS LOBSTER* tracer ribbon in the weak red and candy cane ropes. We are happy to report that these ropes are now 100% being made with the *MASS LOBSTER* tracer ribbon and are readily available.

The MLA is proposing an additional gear marking option for the lobster industry. We are asking the DMF to accept having the *MASS LOBSTER* tracer ribbon be a standalone gear marking should a fisher use the weak red and candy rope for the entire vertical line. Currently, there are numerous fishers fishing full weak vertical lines with the *MASS LOBSTER* tracer ribbon and should not have to add additional gear markings.

The amount of time it takes a fisher to mark their endlines is upwards of a 100 plus hours annually. This would be a great way for the State to truly encourage fishers to use full vertical lines of the weak red and candy cane rope with the *MASS LOBSTER* tracer ribbon.

Thank you for your thoughtful deliberation and consideration of our comments. Should you have any question please feel free to reach out anytime.

Kind regards.

*Beth Casoni*

Executive Director



# WE DELIVER FRESH LOBSTER BAIT

**INCLUDING:**

HERRING

POGIES

MACKEREL

RED FISH

SKINS

BLUEFISH

CHUM

SALMON  
HEADS



***FRESH, SALTED, AND QUICK FROZEN BAIT***

## **Barrel Head Bait**

***WE SELL SALT!***

**For More Information:**

**Mark Flight**  
[mark@barrelheadbait.com](mailto:mark@barrelheadbait.com)

**To Place An Order:**

**The Bait Line:**  
**857-200-2129**  
**Or Fax:**  
**617-561-8471**

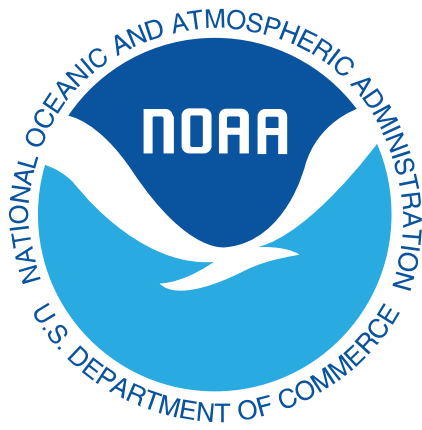

# NOAA Announces Membership for the American Fisheries Advisory Committee

*The committee was established to make recommendations for Saltonstall-Kennedy priorities and grant award funding.*

NOAA Fisheries announced the selection of members for the new American Fisheries Advisory Committee. The committee was established by the American Fisheries Advisory Committee Act in May 2022 to make recommendations for Saltonstall-Kennedy priorities and grant award funding.

The Act requires the committee to have three representatives from each of six regions as well as four at-large members. These must include one representative each from the retail and marketing sector, commercial fisheries, recreational fisheries, and NOAA Fisheries. Members from each of the six regions represent seafood sectors including processors, recreational and commercial fishermen, seafood farmers, fisheries scientists, and regional fishery management council members.

The committee's first meeting will be held in Seattle, Washington, the week of December 12, 2022. They will evaluate and make recommendations for the annual Saltonstall-Kennedy grant competition.



Fishing vessel in Point Judith, Rhode Island.

Credit: NOAA Fisheries

Saltonstall - Kennedy funds provide grants or cooperative agreements for fisheries research and development projects addressing aspects of U.S. fisheries including harvesting, processing, marketing, and associated business infrastructure. These grants and cooperative agreements are made on a competitive basis—subject to availability of funding—to assist in:

- Executing projects that optimize the economic benefits of building and maintaining sustainable fisheries and practices
- Dealing with the impacts of conservation and management measures
- Increasing other opportunities to support working waterfronts

# AMERICAN FISHERIES ADVISORY COMMITTEE

Below are the members from each region and the sectors they represent. Remaining members will be upon confirmation of their appointment.

## REGION 1 – ALASKA, HAWAII, COMMONWEALTH OF THE NORTHERN MARIANA ISLANDS, GUAM, AMERICAN SAMOA

- Phillip Fernandez, Hawaii – Science/Management
- Rebecca Skinner, Alaska – Fishing/Farming
- Julianne Curry, Alaska – Harvester/Processor

## REGION 2 – MAINE, NEW HAMPSHIRE, MASSACHUSETTS, RHODE ISLAND, CONNECTICUT

- Mark Alexander, Connecticut – Science/Management
- Beth Casoni, Massachusetts – Harvester/Processor
- Jessica Hathaway, Maine – Fishing/Farming

## REGION 3 – TEXAS, ALABAMA, LOUISIANA, MISSISSIPPI, FLORIDA, ARKANSAS, PUERTO RICO, U.S. VIRGIN ISLANDS

- Michael Stephens, Florida – Harvester/Processor
- John Supan, Louisiana – Fishing/Farming
- Marcos Hanke, Puerto Rico – Science/Management

## REGION 4 – CALIFORNIA, WASHINGTON, OREGON, IDAHO

- Chuck Erickson, Oregon – Fishing/Farming
- Lori French, California – Harvester/Processor
- Pete Granger, Washington – Science/Management

## REGION 5 – NEW JERSEY, NEW YORK, DELAWARE, MARYLAND, VIRGINIA, NORTH CAROLINA, SOUTH CAROLINA, GEORGIA

- Mike Leonard, Virginia – Fishing/Farming
- Charles Phillips, Georgia – Harvester/Processor
- Laxman Kanduri, New Jersey – Science/Management

## REGION 6 – MICHIGAN, MINNESOTA, WISCONSIN, ILLINOIS, INDIANA, OHIO, PENNSYLVANIA

- Ronald Rogness, Wisconsin – Fishing/Farming
- Mark Palicki, Illinois – Harvester/Processor
- Beau Braymer, Michigan – Science Management

## AT LARGE

- Matthew Alward, Alaska – Commercial Fishing Supply Chain
- Derek Orner, NOAA Fisheries Representative
- Confirmation of 2 additional at-large members is pending

[https://www.fisheries.noaa.gov/feature-story/noaa-announces-membership-american-fisheries-advisory-committee?utm\\_medium=email&utm\\_source=govdelivery](https://www.fisheries.noaa.gov/feature-story/noaa-announces-membership-american-fisheries-advisory-committee?utm_medium=email&utm_source=govdelivery)

## Are you thinking of buying or selling?

Boats | State and Federal Permits | Complete Businesses

ATHEARN MARINE AGENCY, INC.



SERVING FISHERMEN SINCE 1946

Tel: (508) 999-4505

Email: [sales@athearnmarine.com](mailto:sales@athearnmarine.com)

[www.athearnmarine.com](http://www.athearnmarine.com)

10 Union Wharf, Fairhaven, MA 02719



**HERCULES**  
SLR (US) Inc.  
MARINE • FISHING GEAR • SAFETY

44 South Street, New Bedford, MA 02740  
Phone: 508-993-0010 Fax: 508-993-9005  
**Securing – Lifting - Rigging**  
82 MacArthur Dr. New Bedford, MA 02740  
Phone: 508-992-9519 Fax: 508-992-9419

[JohnReardon@Hercules-SLR-US.com](mailto:JohnReardon@Hercules-SLR-US.com)

"PULL THE PIN AND THROW IT IN"



**DSPA 5 M**

OUR NEWEST FIRE PROTECTION

[www.Hercules-SLR-US.com](http://www.Hercules-SLR-US.com)

USCG Safety Inspection Station #327

**Commercial Fishing-Marine Safety-Rigging**

- ❖ Marine Hardware
- ❖ Cotesi - Netting, Leaded/Sink Rope
- ❖ Stormline & Climate Technical-Foul Weather Gear
- ❖ Buoys & Floats
- ❖ Lobster Bands
- ❖ PFD's, Vests, Float Coats
- ❖ Fish Totes
- ❖ Insulated Tubs
- ❖ Cordage & Twine
- ❖ Mooring Equipment
- ❖ Boarding Ladders
- ❖ Polysteel Rope- Esterpro Sinking, Hydropro
- ❖ Leadline
- ❖ Wire Rope - FC Galv, IWRC, Dyform
- ❖ HiFlyers 12', 14' & 15' XHD
- ❖ Golf & Batting Cage Netting



Inflatable PFD's



**Life Raft Sales**

- ❖ Revere
  - ❖ Elliot
  - ❖ Survitec
  - ❖ Switlik
- All brands accepted for service



**ACR Electronics**  
Sales & Service  
for your E.P.I.R.B.



**Fenders & Buoys-All Colors**



**Boots from Honeywell Safety**



**On-Board Vessel Inspections & Safety Drills**

Call our USCG Certified Drill Conductors:

Rodney Avila 508-889-0401

Ted Williams 508-264-5779



**Imperial Survival Suits**  
Sales & Annual Inspections  
Done in house



# 2023 SEMINAR TOPICS

# Annual Weekend & Industry Trade Show 2023

## March 23-26, 2023



Resort And  
Conference  
Center  
At Hyannis

35 Scudder Avenue  
Hyannis, MA 02601  
Main Phone: 508-775-7775

The MLA's Annual Weekend & Industry Trade Show 2023 is on track to be better than our last event held in 2019. The MLA Annual Weekend Committee is working hard to bring you industry dealers with the latest in technologies, efficient tools and a multitude of important industry related businesses, organizations, and agencies.

The MLA's Annual Weekend & Industry Trade Show 2023 is an important platform for numerous educational and informational industry related seminars. The MLA Annual Weekend Committee continues to think of new, interesting and timely pertinent topics for seminars and over the years they have proven to be spot on in their selections. While there are numerous recommendations the unfortunate reality here is, there are only a limited amount of seminar slots and they are contemplating all the suggested seminars ideas. Please be advised we staying with the one seminar at a time platform given the importance of the seminar topics and to not create overlap between seminars.

*Some of the seminar topics for the 2023 Trade Show are as follows;*

**1. Right Whale Risk Reduction Measures & Incidental Take Permit Updates**

(MLA, LFoM, GARFO & DMF)

The panel will discuss the ongoing right whale; stock status, rule making & timeline of implementation, ongoing conservation initiatives, implementation of risk reduction measures, the Incidental Take Permit application update and more.

**2. Division of Marine Fisheries, National Marine Fisheries Service & Environmental Police Round Table**

This is an open forum discussion where you can talk about your fisheries concerns. If you have any specific questions for the agencies to answer, please send them to [beth.casoni@lobstermen.com](mailto:beth.casoni@lobstermen.com) by February 17th to allow time to compile the necessary data and response.

**3. MA Lobstermen's Association 60th Annual Membership Meeting**

This meeting is open to ALL MLA members. Come and have a cup of coffee & pastry and hear all of what the MLA has been doing over the past year and see some friends as well.

**4. Offshore Wind in the Gulf of Maine and Southern New England**

(BOEM, GARFO, NEFSC, MAEEA, MACZM, MADMF)

The panel will discuss the current federal process, timeline for lease areas in the Gulf of Maine, timeline for development of offshore wind, fisheries and habitat monitoring, Commonwealth of MA commitment to offshore wind, Fisheries & Habitat Working Group, and more.

**5. Lobster Institute**

Come meet the new Director, Richard A. Wahle, Ph.D., who will give you an overview of what the Lobster Institute has been working on over the last several years.

More seminar information will be forth coming in the January & February newspapers. Also please be advised that these may change as we live in an ever changing world and ALL reservation forms can be found on the MLAs website [www.lobstermen.com](http://www.lobstermen.com) - The Annual Weekend Program will be posted online in mid-March.

***DO NOT DELAY - ROOMS AND BOOTHS ARE FILLING UP!***



# LIFEJACKETS for LOBSTERMEN



— A NEW BEGINNING —

Many of you will remember the Lifejackets for Lobstermen (LFL) van cruising up and down the Massachusetts coast (and Maine too) back in 2019. The team visited 61 ports in their eight months on the road, selling 1,087 PFDs (personal flotation device) at 50% off. Hopefully many of those PFDs are still being used today with appropriate inspections and repackaging if the model requires it. We're hopeful that other fishermen have been motivated to seek out a PFD that works for them after observing their peers working in models they purchased from us.

If you are looking for a PFD you can work in and that is affordable, we're happy to say Lifejackets for Lobstermen has never really gone away. The program is now run by Fishing Partnership: Support Services (FPSS):

<https://fishingpartnership.org/>

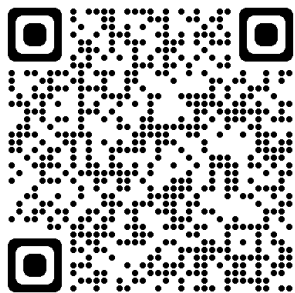

Lifejackets for Lobstermen van with Jacob Cabral (Liferaft Services), Christopher Quill (Liferaft Services), Erin Lally (NEC), Jessica Church (Three Lantern), Lauren King (FPSS), Amanda Roome (NEC), Nina Groppo (FPSS), Rebecca Weil (NEC)

and has been rebranded as Lifejackets for Fishermen. Anyone taking a safety course with FPSS or getting a quick PFD training with a FPSS staff member will receive a voucher for a 50% rebate on a PFD purchase that can be used at any marine supply store. This means any fisherman in any fishery in any area FPSS works in is potentially eligible to

participate, so tell all of your fishing friends outside of Massachusetts.

If you visited the van or met the team, you probably heard them say, "The best lifejacket is the one you wear." This is absolutely true and we encourage you to try on as many if you can when shopping for a PFD. That said, there were

some clear favorites among lobstermen based on interviews, trials and sales data.

Over half of the PFDs sold from the van were Storm-line Flotation Bibs. Fishermen liked them because the flotation padding was combined with something they were already wearing. That said they are not certified as a lifejacket, though can

be considered a buoyancy aid to buy you some time for rescue.

The second most popular was the Mustang Survival Elite 28 MD5183. It's a USCG certified automatic inflatable unit that lays flat when at work and can flip most wearers face-up. Similar in popularity was the Kent Rogue II Fishing Vest. While not certified as a life-jacket, it is a buoyancy aid and wearers found its low profile foam to be comfortable and warm in winter, with many sizing options available. The next three were nearly equal in popularity despite each providing a different type of flotation. The Hyde Wingman is a USCG approved manual inflation device that fishermen found to be low profile and comfortable. The Mustang HIT Workvest MD3188 is also USCG approved, with automatic inflation. Its advantages were very similar to the Mustang Survival Elite 28. Finally the Stearns Ship Mate II was a popular USCG certified foam PFD, which was useful for all swimming abilities. Stearns has stopped manufacturing them, but an excellent substitute is the Mustang Classic Industrial Flotation Vest/MV3196 T2.

Shifting gears, as we head into the winter months, it is important to address the safety risks associated with colder water temperatures as well as ways to increase chances of survival in the event of cold water immersion. "1-10-1" is a phrase coined by Dr. Gordon Giesbrecht of Cold



Anthony Pizzimenti in Rockport, MA

Water Bootcamp:

<http://www.coldwaterbootcamp.com/pages/home.html>

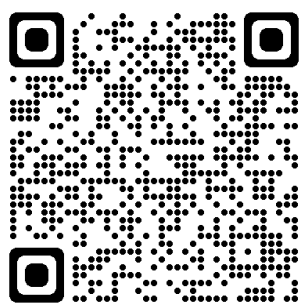

He uses this to describe the three critical phases of cold water immersion and the approximate time spent in each phase. **1: One Minute**, the first phase (Cold Shock) is the initial gasp and hyperventilation upon entering the water, **10: Ten Minutes**, is the second phase (Cold

Incapacitation) in which you will lose control of the arms and legs over a period of about **10 minutes**. **1: One Hour**, In the final phase (Hypothermia) it can take approximately **one hour** before becoming unconscious due to hypothermia.

Given the fact that people immersed in cold water have 10 minutes of meaningful movement, and most rescues take longer than 10 minutes, a PFD is crucial for surviving a falls overboard, especially in winter. It is important to note, however, that inflatable PFDs are not recommended for cold water, as freezing temperatures can negatively affect the function of the CO2 gas cylinder. When

using an inflatable PFD, it is especially important to thoroughly inspect the device to ensure the CO2 cylinders have not been fired and the device is ready to be activated in the event of an emergency.

For more details on life-jackets that were part of the LFL project visit the NE Center website:

<https://necenter.org/portfolio/lifejackets-for-lobstermen/>

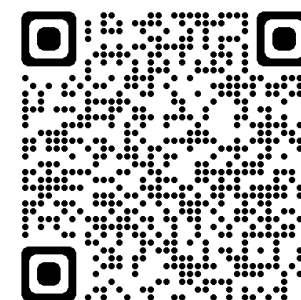

# End-of-Year Store Specials

*While supplies last!*



**Perone 6x14 2nd Buoys**  
Case of 24, \$199



**Tytan Marking Tape**  
\$6 per roll

**Radar Reflectors**  
Small 9": \$13.25  
Large 12": \$16.50

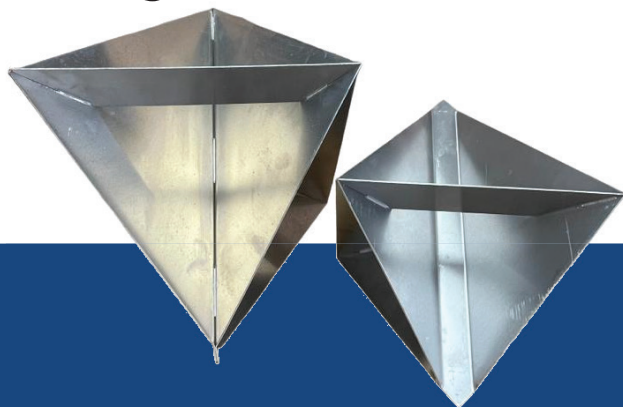

**ProFlex 1**  
**11/32" Sink Line**  
1200 foot coil  
\$108

111 Myrtle Street  
New Bedford, MA 02740  
508.997.4787



www.ketchamsupply.com  
info@ketchamsupply.com  
@ketchamtraps





*Happy Holidays*

OVER 20 YEARS EXPERIENCE ~ ALL MATERIALS & SIZES

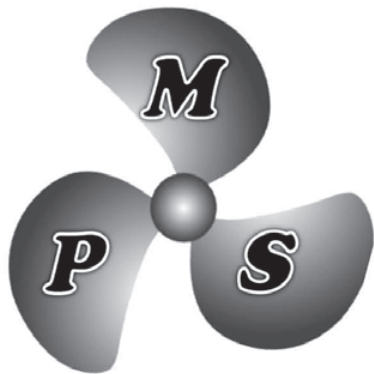

**FOR FAST SERVICE  
CALL MIKE @  
508.979.8000**

[marine.propeller128@gmail.com](mailto:marine.propeller128@gmail.com)

**MARINE**  
PROPELLER SERVICE

**REPAIRS &  
RECONDITIONING**  
(Fast & Fully Insured)

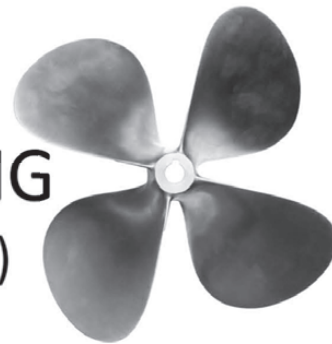

*THE MOST RELIABLE PROPELLER SERVICE COMPANY ON THE SOUTHCOAST*

**74 MAIN STREET FAIRHAVEN MA 02719 508.979.8000 FAX 774.206.6449**

# Ruling

FROM PAGE 1

3) While we asked that NMFS be given until 2030 to issue a Final Rule, he ordered that NMFS shall issue a Final Rule consistent with his July 8, 2022 opinion, by no later than December 9, 2024;

a. I will note that initially, Maine, Maine MLA, NMFS, and MLU all agreed that the Court should decide vacatur by December 9, 2024, but we remained steadfast that this was unrealistic given that NMFS itself said it needed until 2030. By the time of oral argument, these other parties, including NMFS, moved to our position.

b. Now, while the Judge ordered that NMFS needs to issue a new Final Rule by December 2024, he agreed that the decision regarding whether the BiOP should be vacated would occur after that. In pertinent part, the Judge wrote – “The Court expects that after the promulgation of the Rule in December 2024, it will seek briefing from the parties on whether to vacate the BiOp and in what timeframe. While this decision means that no new BiOp is required in the next two years, the Court would expect to ultimately order one closer to that timeframe than to the 2030 date...”

c. This pleases me as our efforts in remaining steadfast bought everyone more time, and, while he did not adopt the 2030 date, it is likely any decision would be well after 2024, but not as far out as 2030.

4) As we first proposed to hold NMFS’s feet to the fire, the

Judge also ordered that the parties file a joint status report by July 10, 2023, and every six months thereafter, detailing progress in complying with this Order.

Lastly, we are also pleased as our role at oral argument was to argue that, under the Court’s Allied Signal test, vacatur of the Final Rule, while NMFS corrects its mistakes, would be inappropriate because disruption to the industry would be significant. Happily, the Court agreed and stated, “[h]ere, the disruption to the lobster industry would be quite significant.” Indeed, the Judge stated, “[a]lthough the parties dispute the extent to which such a shift would occur and what damage to the whales it would cause...it nonetheless appears to the Court that there are at least open questions concerning the species benefits that would accompany these great costs to the lobstermen.” In other words, he recognized that the regulatory measures proposed would impose “great costs to the lobstermen,” while recognizing there is a question of whether these measures would do anything to help the Right Whale.

Please also remember the appeal regarding NMFS’s errors in the BiOP remains ongoing and will likely help in instructing NMFS to issue a new Rule allowing our members to fish without crushing closure and regulation.

*We live to fight another day!*

*Sam Blatchley of  
Eckland & Blando LLP,  
MLA’s attorney,*



Encore Hartco Tools & Clips  
Stanley Spenax Tools & C-Rings  
Wematic Tools & D-Rings  
Simonds Pneumatic Wire Cutters  
Spotnail Staplers & Staples



(781) 826-2522  
Fax (781) 826 5252  
www.fisherairfasteners.com  
chris@fisherairfasteners.com

Complete Parts Inventory  
Tool Repair Service



# Rose Marine

Gloucester, MASS [www.rosesmarine.com](http://www.rosesmarine.com)

Aqualoy Stainless  
Propeller Shafts & Accessories



Largest stock of **Aqualoy** Prop  
Shafting on the East Coast.  
*Emergency* turn-around time available.



Call or e-mail Peter Tetrault  
for a price.  
[peter.tetrault@rosesoil.net](mailto:peter.tetrault@rosesoil.net)



**877-283-3334**



**ROTZLER**  
TITAN TI

**Hydraulic Hoisting Winch**

Four Models from  
2,850lb – 12,300 lb Pull Capacity



Quality Oil Coolers  
Made in the U.S.A



- All Seamless Tubing
- High pressure available
- 90/10 copper-nickel

## Mufflers and Exhaust Components



*Stainless Steel Mufflers*  
2" – 8" inlet size in stock



**BelMar**  
Industries

## Anchor Flush Mount Hatches

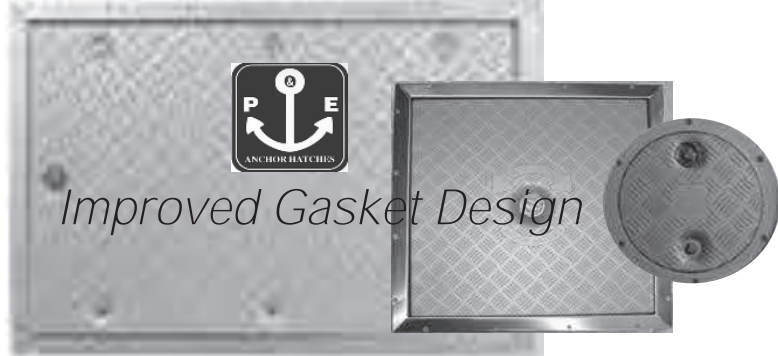

*Improved Gasket Design*



**KOBELT**

Controls



**Cablecraft**  
PUSH-PULL CONTROLS

*Ask for the  
Green Marine*

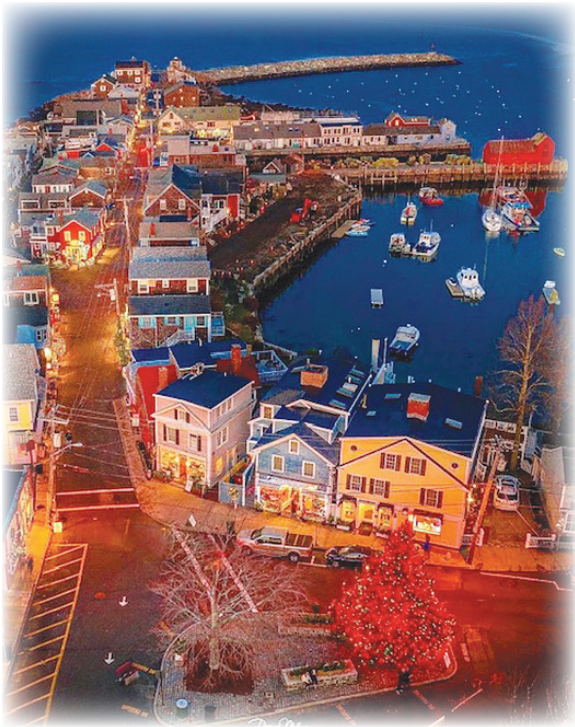

Merry Christmas!





# NEW ENGLAND PROPELLER, INC.

Distributor of Michigan Propellers

**Inboard • Outboard**

Next Generation 3D Computerized Propeller Analyzer  
Computerized Dynamic Balancing



## Marine Fuel Tanks

Custom Fabricated & Tested to U.S.C.G Specifications  
*By Capeway Welding*

- Marine Propeller Sales & Repairs - ***4000 Props in Stock***
  - Sierra Engine Parts for All Outboards & IOs
  - CDI Electronics • Camp & Godfrey Zincs
    - NGK Spark Plugs
  - Duramax Cutless Bearings • Spurs Line Cutters
    - PSS Dripless Shaft Seals
  - Buck Algonquin - Struts, Rudders & Stuffing Boxes
    - S/S Shafting • Drive Savers • Globe Impellers



9 Apollo Eleven Rd., Plymouth, MA 02360  
Tel: 508-747-6666 800-635-9504 - [neprop.com](http://neprop.com)



The American Fisheries Advisory Committee (AFAC) <https://www.govtrack.us/congress/bills/117/s497/text> was just recently passed and signed into law by President Biden in May 2022. This committee of seafood industry experts was an original part of the Saltonstall Kennedy Act (SK) of 1956 where they were given the charge, in statute, to “Promote and Develop Seafood Products” with the goal of “increasing the free flow of domestic seafood products through Commerce.”

AFAC’s primary charge with the SK grant program, also in statute, is to design and conduct a grant program that includes the “...expansion of domestic and foreign markets for United States fishery products”. It is therefore suggested to the Senate Appropriations Committee that “...15% of the SK Transfer from USDA” is justified to provide for a more robust version of the traditional SK competitive Grant program and to also provide for a sustained, multi-year, National Seafood Promotion program?

The requested number of 15% (\$36M based on 2021 im-

port duties) is a minimal amount for such an effort, but it is a place to start to build the needed credibility with Congress that everything with AFAC and a new national seafood promotion is going along as they will expect. It is also “minimal”, based on the 1983 amendment to the SK Act that “requires” 60% of the transfer be used for the SK Grant programs. This requirement is essentially ignored by Congress every year.

Coincidentally, or not, US Senator Wicker introduced on September 29th 2022 a bill that once again seeks to create the National Seafood Council. This Council seeks \$25M per year for 5 years (with no specific funding source) to promote the health and nutrition of eating seafood. The Fish and Seafood Promotion Act (<https://uscode.house.gov/view.xhtml?path=/prelim@title16/chapter60&edition=prelim>) was passed in 1986. It primarily included a process to assess groups of seafood producers to fund promotions relative to the species being assessed. Also included in the Act was a limited try at a National Sea-

food Council that operated with questionable success for 5 years. The entire process of that Act has the very heavy hand of NOAA on it throughout, and was never accepted or used by the US Seafood Industry, even having been “re-tried” over and over every 10 years or so. Senator Wicker and the hard push by a few supporters are right on schedule trying to do it again.

By passing the American Fisheries Advisory Committee Act in May 2022, a National Seafood Council has in actuality and charge, been formed, effectively eliminating the need to attempt to form a competing (for funding and even messaging) entity that has essentially the same function and has never worked out for the industry.

After all advisory committees were “dissolved” by Congress in 1972, AFAC is back with all of its original authority and statutory funding source. If the present push for a new National Seafood Council legislation is absolutely sincere in their desire to promote the health and nutrition benefits of seafood

and to increase the consumption of seafood in the US, the entire seafood system should refocus within the existing AFAC process.

AFAC is charged with interacting and consulting with the entire Seafood industry, from the boat to the throat, to consider everything that may help with the expansion of domestic and foreign markets for United States fishery products.... what could be more clear or straight forward?

Including the Competitive SK Grant Program, a National Seafood Promotion will be designed by the industry, including aquaculture, retail and food service as they work closely with the new American Fisheries Advisory Committee to take the message of Seafood to the market.

Rather than taking the extended time, energy and money to try to pass new national legislation, entities such as MAFAC, the retailers, wholesalers, marketers, nutritionists, universities, processors, fishermen, exporters, importers and the consumer, should all get behind the newly re-authorized AFAC, and join AFAC and the broader US Seafood Industry in asking the Congressional Appropriations process to fund the American Fisheries Advisory Committee to the extent sufficient for the traditional SK Grant program and a new and continuous National Seafood Promotion.

Everything is now in place, so let’s all simply let AFAC use their authority, their statutory funding source, and their broad, national representation to carry out the process of making it happen.

*By: Bruce Schactler,  
Kodiak, AK*

# SAVE THE DATES

## U.S. - CANADA LOBSTER TOWN MEETING FEBRUARY 3 - 4, 2023 MARINER'S CHURCH EVENT CENTER, PORTLAND, ME



We are pleased to announce the return of the U.S. - Canada Lobster Town Meeting in Portland, Maine, February 3 - 4, 2023. As in the past, the meeting will address pressing issues affecting the lobster industry in the U.S. and Canada. Town Meeting is a unique opportunity for cross-border dialog among fishermen, managers, and researchers. Please mark your calendars and plan to join us for a candid and lively facilitated discussion.

**This year's theme: The North Atlantic right whale & the lobster fishery**

- Impacts of regulations on harvesters
- Impacts on markets
- Solutions & technology
- Shifting distributions in a changing climate

**Friday, February 3**

- 9 a.m. - 4 p.m. Sessions and Discussion
- 4 p.m. - 6 p.m. Seafood Reception

**Saturday, February 4**

- 9 a.m. - noon Sessions, Discussions, and Wrap Up

A registration fee of \$75 per person includes:

- Sessions on February 3 & 4
- Breakfast on February 3 & 4 (from 8 - 9 a.m.)
- Lunch on February 4
- A Seafood reception on the evening of February 3

**Hotel & Venue**

The Hilton Garden Inn Portland Downtown Waterfront (across from the Maine State Ferry Terminal on Commercial Street) is providing a group rate of \$117 per room per night and includes parking.

The Hilton Garden Inn is a 3-minute walk to our venue, Mariner's Church Event Center.

- Please use this link (<https://www.hilton.com/en/book/reservation/rooms?cityhocrn=PWMDHGI&arrivalDate=2023-02-02&departureDate=2023-02-05&groupCode=USCATM&room1NumAdults=1&cid=OM%2CWW%2CHILTONLINK%2CEN%2CDirectLink>) to secure your rooms at the group rate.
- Rooms are available on the nights of February 2, 3, & 4.
- To inquire about travel assistance or other questions, please contact Chris Cash at: [christina.cash@maine.edu](mailto:christina.cash@maine.edu) or call 207-581-1443.

We look forward to seeing you all for our first in-person U.S. - Canada Lobster Town Meeting since 2020!

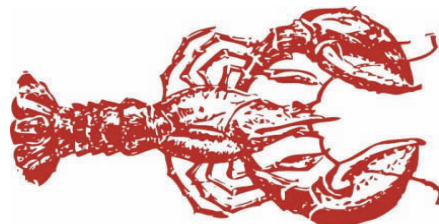

“Specializing in the sale & delivery of  
**LOBSTER BAIT**  
for over 30 years”

**FRESH FROZEN AND SALTED BAIT AVAILABLE**

**SKATES ~ HERRING ~ POGIES ~ HADDOCK ~ COD FISH ~ POLLOCK  
FLAT FISH ~ FISH SKINS ~ RED FISH ~ DOG FISH HEADS ~ SALMON**



**C & P BAIT**  
33 Wright St  
New Bedford, MA 02740

**Contact:**  
Danny Costa 508-951-9818  
Carlos Pereira 508-951-9819



# MAINE'S LARGEST DISCOUNT MARINE STORE!

800-639-2715

hamiltonmarine.com

**HM5**  
YEARS  
**HAMILTON  
MARINE**  
BOATERS' STORE™



Photo by Wayne Hamilton ©

Our flyer is filled to the brim with goodies for the boat lover in your family. From must have knives to stocking stuffers to cozy warm weather gear, there's something for everyone on your list!

Shop our *Holiday Flyer!*

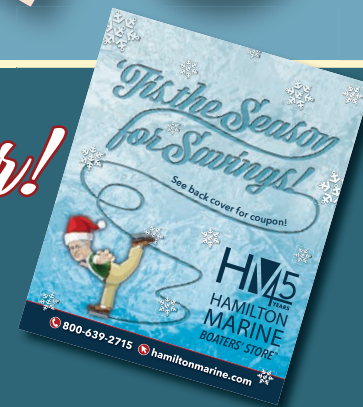

KITTERY • PORTLAND • ROCKLAND • SEARSPORT • SW HARBOR • JONESPORT • MAINE



# Atlantic States Marine Fisheries Commission NEWS RELEASE

FOR IMMEDIATE RELEASE: November 11, 2022 | PRESS CONTACT: Tina Berger, 703.842.0749

## Atlantic Menhaden Board Sets 2023 TAC at 233,550 MT & Approves Addendum I to Address Commercial Allocations, Episodic Event Set Asides, and Incidental Catch/Small-scale Fisheries

LONG BRANCH, NJ – The Commission's Atlantic Menhaden Management Board set the 2023 total allowable catch (TAC) at 233,550 mt, which is an approximate 20% increase from the 2021-2022 TAC based on the positive stock status of the resource under ecological reference point-based management. According to Technical Committee analysis, this increase has a less than 40% probability of exceeding the target set by the ecological reference points (ERPs) adopted in 2020. Given the positive results of the 2022 Stock Assessment Update, the Board approved this modest increase to provide additional fishing opportunities, while maintaining a conservative risk level of exceeding the ERP target.

The Board also approved Addendum I to Amendment 3 to the Interstate Fishery Management Plan for Atlantic Menhaden. The Addendum changes the allocations for the commercial fishery. It creates a three-tiered system for minimum allocations to the states, with Pennsylvania receiving 0.01%; South Carolina, Georgia, Connecticut, Delaware, North Carolina, and Florida receiving 0.25%; and the remaining states continuing to receive a minimum of 0.5%. Furthermore, the Addendum allocates the remainder of the TAC, excluding the 1% reserved for the Episodic Event Set Aside (EESA) Program, on a state-by-state basis based on landings history of the

fishery from 2018, 2019, and 2021. Regarding the Incidental Catch/Small-Scale Fishery (IC/SSF) provision, the Addendum codifies the ability for states to elect to divide their quotas into sectors, enabling individual sectors to enter into the provision at different times. Additionally, the Addendum removes purse seines as a permitted small-scale directed gear, thereby, prohibiting them from harvesting under the IC/SSF provision. Finally, the Addendum counts IC/SSF landings against the TAC and if IC/SSF landings cause the TAC to be exceeded, then the Board must take action to modify one or both of permitted gear types and trip limits under the provision.

The Board initiated Draft Addendum I in August 2021 in response to the recommendations of a Board Work Group charged with evaluating provisions of the current management program and providing strategies to refine those provisions. Under the EESA Program, 1% of the TAC is reserved at the start of the fishing year and Northeastern states from Maine to New York who can demonstrate a large influx of menhaden and have caught their state quota may apply to harvest during the event to reduce discards and prevent fish kills. Additionally, after a state quota allocation is met, the state may enter into the IC/SSF provision where certain small-scale directed gears and non-directed gears may continue to harvest

menhaden at a reduced trip limit.

Since Amendment 3 was adopted in 2017, the EESA and IC/SSF provisions have been impacted by recent trends in landings. The impacts have been most notable in New England, where states rely on the EESA to keep their commercial fisheries open while working to secure quota transfers. An increasing abundance of menhaden in New England has led to a rise in landings under the IC/SSF provision once commercial quotas have been met. Addendum I aligns state quotas with recent landings and resource availability while maintaining access to the resource for all states, reduce dependence on quota transfers, and minimizing regulatory discards.

The new TAC and allocations are effective January 1, 2023; all remaining measures will become effective May 1, 2023. States implementation plans must be submitted by January 1, 2023 for Board review at the Winter Meeting. The Addendum will be available by the end of November on the Commission website at <http://www.asmf.org/species/atlantic-menhaden> under Management Plans and FMP Reviews.

*For more information, please contact:*  
**James Boyle,**  
**Fishery Management Plan Coordinator**  
[jboyle@asmfc.org](mailto:jboyle@asmfc.org)  
703.842.0740

**Table 1.**  
**Addendum I Atlantic Menhaden Allocations\***

State	Allocation (%)
ME	4.80%
NH	1.19%
MA	2.12%
RI	0.81%
CT	0.33%
NY	0.86%
NJ	11.00%
PA	0.01%
DE	0.27%
MD	1.17%
PRFC	1.09%
VA	75.20%
NC	0.37%
SC	0.25%
GA	0.25%
FL	0.29%
<b>TOTAL</b>	<b>100.00%</b>

\*Note: Allocation percentages shown here are rounded for clarity, quotas will be based on unrounded percentages values.

## FISHING PARTNERSHIP



SUPPORT SERVICES

### NAVIGATOR OFFICES



## Connecting You to Massachusetts Health Insurance Year-Round

**2023 Open Enrollment**  
Nov. 1, 2022 - Jan. 23, 2023

Fishing Partnership Navigators can help any MA resident under 65 access health insurance. A Navigator can assist you with applying for coverage, renewing your plan, making changes to your application, or shopping for a new plan.

*Contact a Navigator anytime during the year to apply or make changes to your application.*

*Apply by Jan. 23 to have coverage that begins Feb. 1.*

Massachusetts maintains a mandate for all individuals to have health insurance. Unenrolled residents could pay a tax penalty. Don't risk it - call a Navigator and get covered today!

Scan to Request  
Health Insurance Services

Follow



617-928-3443  
fishingpartnership.org



Visit [MAHEALTHCONNECTOR.ORG](http://MAHEALTHCONNECTOR.ORG)  
for more information



# AQUAMESH®

## Premium Quality Marine Wire



**Proudly  
Made in the USA  
Since 1980**

***Contact us today to locate  
a distributor in your area!***



**1.800.762.6374 • SALES@RIVERDALE.COM • WWW.RIVERDALE.COM**



### Multi-Agency Effort Seeks to Address Climate Change Related Impacts to East Coast Fisheries and Fishing Communities

Over the past year, East Coast fishery management bodies have been collaborating on a Climate Change Scenario Planning Initiative designed to explore how climate change might affect fisheries along the East Coast, and to identify consequences for the future of fisheries management and governance. While climate change is clearly having an impact on Atlantic fisheries and the communities that rely on them, it is impossible to predict exactly what future changes will be. What we can do, however, is to plan now by identifying the possible climate-induced impacts on our fisheries and fishing communities in the years to come and determine ways in which we might address these challenges.

The initiative is exploring how fisheries managers can address changing fish stock availability or distribution caused by climate change and will develop a set of strategies to strengthen fisheries management while supporting fishing communities as the ocean environment changes over time. In order to accomplish this, the scenarios take into account how climate-induced changes to oceanographic, biological, and social/economic conditions could create future challenges and opportunities for East Coast fisheries. In working on this project, fisheries managers and hundreds of fisheries stakeholders from coastal communities are banding together to create a more resilient future for coastal fisheries.

This process consists of six phases, including: (1) developing a framework for the scenario planning process; (2) connecting with stakeholders to seek input on concerns regarding anticipated changes to fishing industries and communities over the next 20 years; (3) exploring the major drivers of climate change in greater depth; (4) developing a series of draft scenarios to address possible futures for East Coast fisheries; (5) assessing developed scenarios to identify actions and recommendations; and (6) monitoring to track key changes and outline necessary next steps.

This multi-agency project is currently in phase five, which consists of strategizing on management solutions to draft scenarios. In this phase, the discussion is focused on adaptiveness, using sound data and science, acknowledging alternative ocean uses, and encouraging cross-jurisdictional management efforts. Currently, the group is in the process of conducting brainstorming sessions with fisheries managers to discuss possible strategies and actions managers can take to address concerns raised in the various draft scenarios. During the upcoming Commission and Council meetings in November and December, respectively, each body will hold more in-depth discussions of the scenarios to develop ideas and recommendations to support the Scenario Planning Summit. The scenarios will be used as a platform for these discussions,

in which the management bodies will consider questions such as:

- Under each scenario, what are the challenges and opportunities that fisheries governance and management would face?
- How well would our current fishery governance and management arrangements cope if these new scenario conditions were to occur?
- What needs to change in fisheries governance and management to prepare for these scenario possibilities?
- What are the tools and processes that need to be advanced now in order to ensure that fisheries are governed and managed effectively in an era of climate change?

Following the Commission's and Councils' discussions, the Summit will be held in early 2023 to bring together representatives from participating organizations across the region. The Summit will serve as a venue to discuss the input from the manager sub-group and individual management body sessions, with the goal of developing a set of governance, management, and monitoring recommendations from the scenario planning process. Recommendations generated at the Summit will be refined into a final report following the meeting.

In addition to this work, the Commission's Habitat Committee recently released its *2022 Report on Atlantic States' Climate Change Initiatives*. The report contains information on current climate change initiatives underway by each of the Atlantic coast state agencies. This report is a great informational tool for stakeholders to better understand the initiatives underway in their respective areas. More on this report can be found on page 11.

As we continue to see the adverse effects of climate change impact our lives, the Commission is increasingly aware of the importance of developing adaptive fisheries management guidelines and governance to support successful sustainable fisheries. The Commission is committed to working in a collaborative manner to ensure fisheries managers continue to communicate with stakeholders as fish stocks may change in distribution, abundance, or productivity over time. Addressing this issue with adaptive efforts such as the Climate Change Scenario Planning Initiative is an essential step forward to serving the needs of our stakeholders and discerning how to best support our shared resources over time.

In writing this article, our colleagues and friends throughout the Southeast are now dealing with the aftermath of Hurricane Ian. Our thoughts and prayers go out to them as they begin to rebuild their lives and communities.

# Atlantic States Marine Fisheries Commission Stock Assessments

## Guidance and Oversight

Coordinating the efforts of the Atlantic coastal states in the development and implementation of interstate fisheries management programs is the Commission's primary role, with stock assessments forming the basis

of management programs. The Commission assesses fish stocks to determine their status, to evaluate how stocks have been affected by management actions, and to forecast future stock conditions under potential new management actions. In fisheries, determining stock status means

estimating the size of the population, either in numbers of fish (abundance) or the total weight of the population (biomass), and the rate at which fish are removed by fishing (fishing mortality rate). Population size and fishing mortality rate are compared to reference points that

define sustainable conditions to determine whether the stock is overfished (the population size is too low) or overfishing is occurring (the fishing mortality rate is too high).

The Commission conducts stock assessments on Commission-managed species in order

Long-Term Stock Assessment Schedule (Board Approved August 2022)

Species	2018	2019	2020	2021	2022	2023	2024	2025	2026
American Eel					Benchmark				
American Shad			Benchmark						
American Lobster			Benchmark					Benchmark	
Atlantic Croaker							Benchmark		
Atlantic Menhaden		Benchmark			Update			Benchmark	
Atl. Menhaden ERPs		Benchmark						Benchmark	
Atlantic Sea Herring	Benchmark		Update		Update		Update	Benchmark	Update
Atlantic Striped Bass	Benchmark				Update		Update		Update
Atlantic Sturgeon							Benchmark		
Black Drum					Benchmark				
Black Sea Bass	Update	Update		Update		Benchmark		Update	
Bluefish	Update	Update		Update	Benchmark	Update		Update	
Coastal Sharks			Benchmark			Benchmark			
Cobia		Benchmark						Benchmark	
Horseshoe Crab		Benchmark					Update		
Horseshoe Crab ARM				Benchmark					
Jonah Crab						Benchmark			
Northern Shrimp	Benchmark			Update			Update		
Red Drum					Benchmark		Benchmark		
River Herring						Benchmark			
Scup	Update	Update		Update		Update			
Spanish Mackerel					Update				
Spiny Dogfish	Update				Benchmark				Update
Spot							Benchmark		
Spotted Seatrout									
Summer Flounder	Benchmark			Update		Update		Update	
Tautog				Update			<i>*Update</i>		
Weakfish		Update						<i>*Update</i>	
Winter Flounder			Update		Update		Update		Benchmark

**Notes:**

- Coastal Sharks Hammerhead benchmark assessment 2023
- Spotted Seatrout States conduct individual assessments
- Striped Bass 2027 Benchmark Assessment

- ASMFC Peer Review
- SARC Review (Research Track)
- SEDAR Peer Review (Research Track)
- Completed

*\*Italics = under consideration, not officially scheduled*

to determine the health and status of the fish stocks and to provide scientific advice to fisheries managers. The Commission also works closely with NOAA (National Oceanic and Atmospheric Administration) Fisheries Science Centers and Regional Fishery Management Councils on the assessments for jointly or cooperatively managed species, such as Atlantic herring, summer flounder, and Spanish mackerel.

Generally, the Commission conducts two types of stock assessments: (1) a benchmark stock assessment and (2) a stock assessment update. A benchmark stock assessment is a full analysis and review of the stock condition, focusing on the consideration of new data sources and newer or improved assessment models. This assessment is generally conducted every three to five years and undergoes a formal peer review by a panel of independent fisheries scientists (peer-reviewed stock assessment). A stock assessment update incorporates data from the most re-

cent years into the peer-reviewed assessment model to determine current stock status (abundance and overfishing level).

### Peer Review

In order to ensure the quality and credibility of its stock assessments for management use, the Commission oversees a formal external peer review process to evaluate all benchmark assessments to determine whether the data and methods used to produce the assessment are scientifically sound and appropriate for management use. The Commission's stock assessment peer review process also includes regional programs following similar procedures coordinated by [NOAA Fisheries - the Northeast Stock Assessment Workshop/Stock Assessment Review Committee \(SAW/SARC\)](#) and the [SouthEast Data and Assessment Review \(SEDAR\)](#).

### Northeast Region Coordinating Council

Within the Northeast region

the Commission, along with NOAA Fisheries Greater Atlantic Regional Fisheries Office, the Mid-Atlantic Fishery Management Council, the New England Fishery Management Council, and NOAA Fisheries Northeast Fisheries Science Center, also participates as a member of the Northeast Region Coordinating Council (NRCC). Formed in 2001, the NRCC's mission is to "prioritize, communicate, and coordinate fisheries scientific and management resources through in-person meetings that include federal, state, council, and commission managers and scientists of the Greater Atlantic Region of the United States."

In 2019, the NRCC established a new and more collaborative fishery stock assessment process with assessments scheduled years in advance to allow for better planning. The process involves two types of assessments – management track and research track. **Management track assessments** provide routine, scheduled, and updated advice to directly inform man-

agement actions. These assessments are designed to be simple, quick, efficient, and flexible; and able to incorporate new information on a regular cycle. Management track assessments ensure that stock status is updated on a regular and predictable basis.

**Research track assessments** are complex scientific efforts that are designed to be carried out over several years. They can: (1) focus on research topics or on one or more individual stocks; (2) evaluate an issue or new model that could apply to many stocks; and/or consider extensive changes in data, model, or stock structure. Both management and research track assessments are generally conducted through SAW/SARC, with the exception of Commission-only managed species, such as Atlantic striped bass and American lobster. For more information on the NRCC process, visit <https://www.nefmc.org/committees/northeast-regional-coordinating-council-nrcc>. <http://www.asmfc.org/fisheries-science/stock-assessments>





New England Marine & Industrial  
[www.newenglandmarine.com](http://www.newenglandmarine.com)

## Lobster Bands

We carry:

Sheddar

Standard

Cold Water Shedder

Jumbo



Buy them by the 1 pound bag, by the case or by the pallet. We also offer wholesale and volume discounts. Call and ask to speak to a salesman.



Dayglo &  
Flexabar  
Buoy Paint



Perone Buoys

Full selection of sizes  
in Stock

### Riverdale/Aquamesh Trap Wire

- Large inventory of trap wire in store
- Variety of sizes and colors available
  - Some trap kits in stock
- Order any size trap kits you may need

200 Spaulding Tpke  
Portsmouth, NH  
603-436-2836

294 Ocean St  
Brant Rock, MA  
781-834-9301

86 Cemetary Rd  
Stonington, ME  
207-367-2692





# Legal Defense Fund Updates

The Massachusetts Lobstermen's Association (MLA) Legal Defense Fund (LDF) needs your support now more than ever. This dedicated fund is for the purpose of defending the Massachusetts commercial lobster fishermen from legal and fisheries management actions that could seriously impact our commercial lobstermen's ability to conduct their businesses and earn a living.

Currently, the MLA is actively engaged in three separate lawsuits that could have negative impacts on the commercial lobster industry and is working with multiple lawyers in Washington D.C. and here in the Commonwealth to fight for you and your industry.

**UPDATE NOVEMBER 18, 2022** — (Washington D.C.) Case 1:18-cv-00112-JEB - CENTER FOR BIOLOGICAL DIVERSITY et al v. ROSS et al, the Plaintiffs requested that the Court issue an order:

1. Declaring that NMFS violated the ESA and APA for issuing an ITS in the 2021 BiOp for zero lethal right whale take in the federal fishery without first authorizing incidental take under the MMPA, 16 U.S.C. § 1371(a)(5)(E);
2. Declaring that NMFS violated the ESA and APA by anticipating but not authorizing lethal take in the federal lobster fishery in the 2021 BiOp ITS;
3. Declaring that NMFS violated the MMPA and APA in issuing a final rule amending the Plan that failed to contain the measures the agency expected would reduce right whale M/SI in the U.S. lobster fishery in both state and federal waters to below PBR within six months of implementation;
4. Vacating and remanding the 2021 BiOp with respect to the right whale and the federal lobster fishery with vacatur stayed for six months and ordering NMFS to produce a new biological opinion that includes fully complies with the requirements of the MMPA and ESA in authorizing any anticipated lethal take of right whales in the federal lobster fishery; and
5. Remanding without vacating the Final Rule and ordering NMFS to issue a new rule within six months of the order that contains the measures NMFS expects will reduce right whale M/SI in the U.S. lobster fishery to below PBR within six months of the rule's implementation.

While we obviously do not agree with their

analysis, science, and most of what they seek (including their apparent opposition to weak rope and intent to push the industry into ropeless fishing), we are encouraged by the fact that we (and others) were able to persuade the NGO's to not seek a restraining order concerning our lobstermen's ability to fish even if the Court vacates and remands the 2021 BiOp and orders NMFS to produce a new biological opinion, that, in the Plaintiffs or in the Court's view, fully complies with the requirements of the MMPA and ESA. As it now stands, the CBD Plaintiffs request that, if the Court vacates and remands the 2021 BiOp and orders NMFS to produce a new BiOp and Final Rule, our fishermen be able to continue to fish as-is for at least 6 months post Court decision and until NMFS fashions a new BiOp and new Final Rule.

NMFS's remedy brief (limited to 30 pages) was filed on September 19, 2022. In its briefing, NMFS proposed the Court set a date of December 9, 2024, for it to issue a TRP amendment remedying the deficiencies in its. As part of this proposal, NMFS also requested that the 2021 BiOp be remanded without vacatur through to December 9, 2024.

NMFS noted the extreme difficulty it would have in meeting Plaintiff's proposed six-month deadline and explained that it would need to take in additional research and data, including on death dispersions from Canada and the US, to make a proper ITS. This is encouraging to see, as the Court recently determined that NFMS's method for assigning deaths between Canada and the US was reasonable (although we strongly disagree).

However, a large part of NMFS's proposed remedy was focused on implementing and advocating a migration away from VBR which is of course untenable for the vast majority of our members.

We submitted our Remedy Brief on October 7, 2022. In our brief we requested that the Court remand without vacatur, so as to keep the Biological Opinion in place while NMFS issues a new regulation. We also requested that the Court not set a hard deadline for NMFS to finish, but rather to require 6-month status updates to give NMFS the time it needs to do this right. Interestingly, the other Intervenor Defendants adopted our strategy, requesting 6 month status updates.

Plaintiff's Reply Brief was filed on October 21, 2022.

All these are on MLAs website home page under the Right Whale Litigation and Management updates.

On November 10, 2022, the remedy hearing was held. It is uncertain what the Court intends to do at this stage, but we are pleased that Maine and the other lobster organizations specifically said they were adopting the position laid out in MLA's briefing and noted that MLA had the right idea first. What's more, the government adopted some of MLA's positions as well.

That being said, the Court laid out three options that it might proceed with:

1. Vacate the Biological Opinion but stay vacatur indefinitely. This was the Court's proposal which it seemed to be presenting as a middle ground but was opposed by all lobster parties as the lobster industry would constantly be at risk of being shut down at any moment. The government was also strongly opposed to this position because it did not think it could get a viable biological opinion done by 2024 that was no jeopardy, while the NGOs unsurprisingly complained that this wasn't sufficient to protect the whales
2. Vacate the Biological Opinion but stay vacatur until December 2024. This was the NGOs' proposal, which would functionally allow the lobster industry to operate until December 2024 but would in reality cause many to decide to leave the business given that the loss of the BiOp would make lobstering impossible.
3. Remand without vacatur. This one was really presented in two possible ways:
  - a. Our proposal, adopted by Maine and Maine Lobstermen's Association, was to remand without vacatur with 6-month status updates so that the lobster industry could continue while a new BiOp was being developed without the risk of it suddenly being shut down.
  - b. Maine Lobstering Union modified our proposal slightly, proposing to remand with the decision on vacatur stayed for 18 months so the Court could determine based on status updates whether to vacate or not.

On November 17, 2022, the Court issued its order, granting the lobster industry a massive win! Adopting the Massachusetts Lobstermen

# LDF Updates

FROM PAGE 33

Association's position, the Court remanded without vacatur, staying a decision on vacatur until December 2024. Further, the Court set a deadline of December 9, 2024, to issue a final order, but did not set a hard deadline for a new Biological Opinion. Instead, it required NMFS to issue status updates every six months starting on July 10, 2023, so that the Court could track NMFS's progress in creating a new Biological Opinion.

**UPDATE NOVEMBER 18, 2022** — (D.C.) Maine Lobstermen's Association, et al. v. NFMS

ORDER GRANTING SUMMARY JUDGMENT - Judge Boasberg has issued his summary judgment order in *MLA v. NMFS* ruling against the Maine Lobstermen's Association (and us) on every single ground we raised challenging the 2021 BiOp. This is a very disappointing order that we appealed to the D.C. Circuit. In his Order, Judge Boasberg did the following:

1. The Court then found that several grounds raised by the Maine Lobstermen's Association should have been brought in the complaint and, because they were not, the Court would not consider them. This includes the following arguments: (Opinion at 11)

- a. Regularly Flexibility Act
- b. MMPA's purposes
- c. Composition of the take-reduction team

2. Turning to the challenges to the BiOp itself, the Court first ruled as a general matter that NFMS applied the "best scientific and commercial data available", meaning that challenges to NFMS' scientific determinations were not going to succeed. It made this ruling on the basis that data was limited and the agency made valid determinations within the range of scientific judgment

a. As part of this conclusion, the Court dismissed the argument that the NFMS' Consultation Handbook required different scientific analysis by determining that it only requires using the best scientific, which the Court believed NFMS used

3. We then arrive at the more specific claims that was raised against NFMS

a. US/Canada Allocation: The Court determined that the data about where deaths were occurring was uncertain so it was fair for NFMS to use a 50/50 split, especially when the Center for Independent Experts determined the approach was "reasonable".

b. Unknown Origin Entanglement: The Court determined that the unknown origin

death data was limited and that it wasn't unreasonable to attribute it to gillnet fishing and VBR especially since deaths seem to happen in VBR areas.

c. Cryptic Mortality: The Court determined that NFMS used a "rigorous peer reviewed method" developed by whale researchers to determine where deaths occurred and that the fact that whales migrate doesn't affect this.

i. The court also determined that natural mortality challenge was adequately explained by NFMS as mostly occurring to whale calves so adult deaths are likely caused by humans.

d. The Court also wholly rejected any reliance on harm mitigation methods deployed by MLA because NFMS did not have access to data on the mitigation measures but incorporated the effects into its modeling as best it could

e. Finally, the Court determined that NFMS could use the "Linden model" and the Decision Support Tool because they are peer-reviewed and thus constitute best date

4. The Court rejected the argument that NFMS attributed too many deaths to the lobster industry, explaining that NFMS had to fall below the PBR because it was just one part of many government agencies impacting whale populations and thus could overestimate the harm

5. Having found that the BiOp survives the challenges against it, the Court then said that the Final Rule also survived because the only challenge to it was that the BiOp was invalid

At the end of its Order, the Court did note that it "fully expects that NMFS will continue diligently incorporating the latest information, considering the concerns of all stakeholders, and adapting to changing circumstances in making its future decisions". (Order at 33).

We disagree with the Court on each of the grounds it found and will vigorously challenge them on appeal.

For the Appeal, the D.C. Circuit set a briefing schedule where Appellant (meaning Maine Lobstermen's Association) and Appellant-Intervenor (meaning us, the Maine Lobstering Union, and the State of Maine) briefs are due on November 9, 2022. The D.C. Circuit originally only granted the Appellant-Intervenors two briefs between the three of them, with a total word limit of 9,100. After briefing, we now get our own brief of 4,050 word limits, MLU gets its own brief of 4,050 words, and the State of Maine get its own brief of 6,000 words.

Our brief informed the Court about the importance of the lobstering industry to Massachusetts and focused on the clearly erroneous

data used by NMFS and pointing out to the D.C. Circuit that the law requires NMFS to use the best evidence available, which they failed to meet.

The State of New Hampshire also joined in the briefing with an amicus ("friend of the court") brief, explaining the impact of NMFS's regulations on the State of New Hampshire, and the Maine State Chamber of Commerce has submitted an amicus brief as well, explaining the economic impact on the lobster industry in Maine.

All these are on MLAs website home page under the Right Whale Litigation and Management updates.

Appellees (meaning NMFS) and Appellee-Intervenors (the NGOs) have their briefs due on December 20, 2022.

The Reply Briefs are due on January 10, 2023.

The commercial lobstermen's businesses are at stake as well as the thousands of jobs and shore side businesses that depend upon the continued success of the commercial lobster industry. The commercial lobstermen in Massachusetts are NOT to the problem and have done everything asked of them by National Marine Fisheries Service and have been working under the strictest conservation rules for the right whales anywhere in the world since 2014. Yet here we are, still fighting these lawsuits to keep the Massachusetts commercial lobstermen fishing.

The Massachusetts Lobstermen's Association has been actively involved in these lawsuits since 2018 and we need your generous support today to continue our fight to keep the commercial lobstermen fishing. As we all know, any legal action costs lots of money and over the last 5 years the Massachusetts Lobstermen's Association Legal Defense Fund has spent over \$300,000 fighting these legal battles. These are real threats to the historic and iconic commercial lobster industry and we are doing everything to keep the Massachusetts commercial lobstermen fishing.

## WHERE TO MAKE DONATIONS

Any contribution you can afford to make to the Legal Defense Fund is greatly appreciated.

### Donate by mail:

MLA LDF,  
8 Otis Place  
Scituate, MA 02066

### Donate online:

[www.lobstermen.com](http://www.lobstermen.com)

– In the Members section  
select Dues/Donate.

**THANK YOU FOR YOUR CONTINUED SUPPORT!**



**DONATE TODAY!**

to the Massachusetts Lobstermen's Association

**LEGAL DEFENSE FUND**

**NOV 2022 SUPPORTERS**

Richard Aprans

Tessa Browne

Joshua Carnevale

John Carver

D.J. Davis

Jason Drake

Peter Vincent Libro

Eric Lorentzen

William Mahoney

Peter Merrit

William Mulvey

Therese Sauvageau

Arthur Sooky Sawyer

Michael Tupper

**THANK YOU FOR YOUR CONTINUED SUPPORT!**



*Donate to the MLA Legal Defense Fund to*  
**“Band the Bite” TODAY!**

Help us fill the lobster crate and help relieve the **“PINCH”** of defending commercial lobstermen!

**Let's fill the lobster crate TODAY!**

Every \$25 dollars donated puts another lobster in the lobster crate!!

**There are several ways to make a donation**

MLA website: [www.lobstermen.com](http://www.lobstermen.com) Legal Defense Fund Donation

Paypal: Legal Defense Fund Donation

Mail or drop off a check:

MLA, 8 Otis Place, Scituate, MA 02066

Call the MLA : 781-545-6984 xt2

Use your camera on your phone to Scan the QR Code

***THANK YOU for YOUR CONTINUED SUPPORT!***





# New England Marine Engineering & Supply, Inc.

Marine • Industrial • Commercial • Refrigeration

10 TON ELECTRIC TITANIUM RSW  
INTEGRATED MARINE SYSTEMS

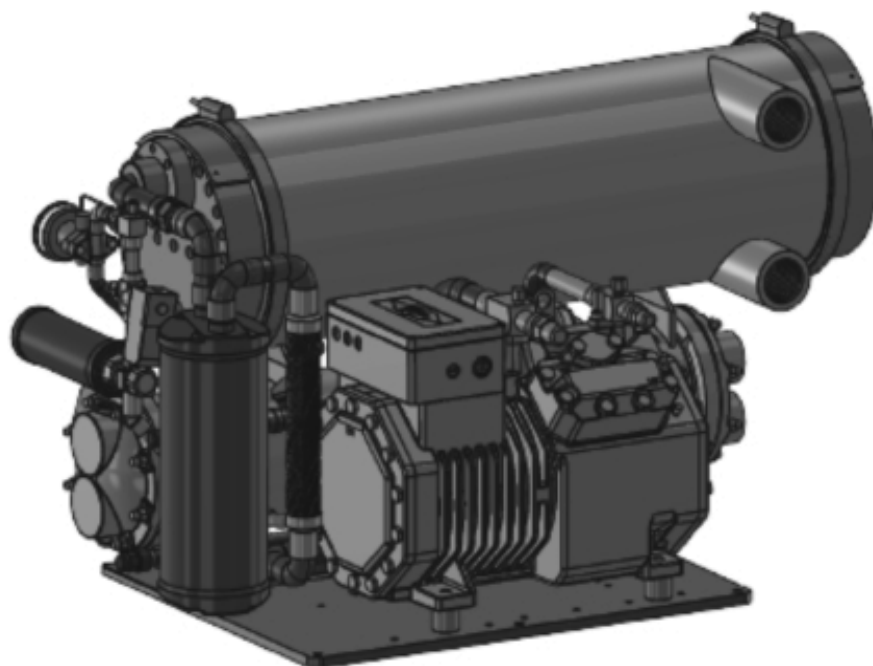

"New England Marine Engineering & Supply, Inc & Integrated Marine Systems, Inc is proud to announce & debut the new IMS 10 Ton Titanium Electric RSW at the 2018 Seafood Processing North America Show on March 11-13 Booth 1875. Come see us and be the first to view the latest IMS system to be introduced to the industry for the fishing vessels ranging from 40' - 80'.

It's going to be the talk of the show."

133 North Front Street, New Bedford, MA. 02740

[www.nemesinc.com](http://www.nemesinc.com) 1.800.540.8893

Massachusetts Lobstermen's Association  
 8 Otis Place, Scituate, MA 02066  
 Office 781-545-6984  
 Fax 781-545-7837  
[www.lobstermen.com](http://www.lobstermen.com)



## MEMBERSHIP APPLICATION

TYPE OF MEMBERSHIP       Full Voting       Associate       Business  
    \$200 Annual Dues      \$200 Annual Dues      \$300 Annual Dues

**\*To qualify for a Full Regular Membership, you MUST (1) hold a valid Mass. Commercial Lobster License, (2) reside in Massachusetts, (3) be sponsored by either two Regular Members or one Delegate, and (4) send in a copy of your lobster license with this application.**

Sponsors:

#1 Name \_\_\_\_\_ [ ] Delegate [ ] Regular Member  
 #2 Name \_\_\_\_\_ [ ] Delegate [ ] Regular Member

Name \_\_\_\_\_

**Business Name** \* Business members will now be listed in 2" x 2" ad in the new MLA business section at the front of the monthly newspaper, a 2" x 2" ad linked to your website will be added to the MLA website, preferential ad location selection in the newspaper and early registration and booth preferences for the MLA Annual Weekend event.

Address \_\_\_\_\_

City/Town \_\_\_\_\_ State \_\_\_\_\_ Zip Code \_\_\_\_\_

Home Phone \_\_\_\_\_ Cell Phone \_\_\_\_\_ Work Phone \_\_\_\_\_ Fax Number \_\_\_\_\_

Email Address \_\_\_\_\_ Website \_\_\_\_\_

Vessel Name \_\_\_\_\_ Homeport \_\_\_\_\_ Permit ID# \_\_\_\_\_ Type of Permit \_\_\_\_\_

[ ] Check here if you would like Hull and P&I Insurance information sent to you

Payment options - Cash, Check, MasterCard or Visa

Credit Card Number \_\_\_\_\_ Exp. Date \_\_\_\_\_ 3 digit security# \_\_\_\_\_ Zip Code \_\_\_\_\_

Signature \_\_\_\_\_ Date: \_\_\_\_\_ / \_\_\_\_\_ / \_\_\_\_\_

# MLA Classifieds

Classified ads are a free benefit to MLA Members and Non-members are a flat \$25.00. Ads run for 5 months & will be automatically deleted unless you call the MLA office to renew. **781-545-6984** or email ads to: [tracey.abboud@lobstermen.com](mailto:tracey.abboud@lobstermen.com)  
\*All ads are subject to review prior to placement

AD #1 (10/22) **FOR SALE** – Area 1 Coastal Lobster Permit Call 508-824-0177.

AD#2 (9/22) **FOR SALE** – Trap Trailer 6x12 can hold approx. 50-3 footers. Good shape. \$1,200.00 Call Ben@ 978-578-8882.

AD#3 (10/22) **FOR SALE** – Hydraulic Components, parts and service. Pumps, Motors, Valves and Accessories. Hydraulic Hoses made while you wait. Great Prices–Same day service (in many cases)–Wide selection of in-stock items. Rebuilt items occasionally available. ROSE MARINE, Gloucester, MA 877-283-3334.

AD#4 (10/22) **FOR SALE** - 800 lobster pots 36 x 22 1/2 x 15 5 years old -new -all ground lines included. 10 pot trawls- all spliced. 3-brick in every pot-haul from starboard & kitchen. 10-12 gauge wire. Dick @ 774-218-4701 for more details.

AD#5 (9/22) **FOR SALE** – 24" Crosley net lift \$2,000.00, 15 ft. of 7 1/2 inch mooring chain \$50.00. 20lb. 3/4" stainless steel hog rings B.R.O. 20lb. 1/2" hog rings. 2 – 55 gallon barrels of 7/16th ground line B.R.O. 10-white pingers \$25.00 each Used Gillnets foam and standup B.R.O. Text Only 617-694-4802.

AD#6 (9/22) **FOR SALE** – Marine-land 55 gal Live Lobster Tank \$690.00 John @617-750-3263.

AD#7 (8/22) **FOR SALE** – Cold water dive suit w/all accessories-used once-still in boxes.\$2,000.00 Robert 617-240-5196.

AD#8 (9/22) **FOR SALE** – 38 ft Novi fiberglass over wood- John Deere 6068. 225hp 5,670 hours on Engine-Stearms @8.5/9 knots 14" hauler Simrad Autopilot Inside/Outside steering stations- 150 gal fuel tank- Lobster tank holds 600lbs. Furuno GP-39 S inside- Furuno GP- 32 GPS outside- Furuno Radar, Furuno FCV-292 color video sounder-2VHF. Inside/Outside

2 computer monitors, one face inside-other faces outside steering station. Very quiet engine. Asking \$15,000.00 Call- 978-290-9929.

AD#9 (11/22) **FOR SALE** – 35' lobster boat McPherson built of wood in Nova Scotia in 1976 – glassed over approx. 8 years ago, repowered w/ 1991 120 hp 6cyl Mitsubishi goes up to 9 knot on 1 1/2 gal/hr new exhaust & auto-pilot 2 years ago. Trap ramp, bunks, electronics ect. Boat currently fishing-will be available for purchase December 16th \$25,000 -Call (508) 939-1231.

AD#10 (11/22) **WANT to buy used** - insulated tubs with lids. mrfish@mrfish.com or Ted 843-267-3473.

AD#11 (10/22) **FOR SALE** - Warp– Used & some new, mostly knot free. 76 lbs. 5/16, 33 lbs. 3/18 \$99 takes all 508-269-1406 Plymouth.

AD#12 (10/22) **FOR SALE** - 18' Wooden Lapstreak Skiff. In remarkable condition. Bottom was fiber-glassed before first used. All heavy duty oak ribs, stiffeners, ribs & floor cleats. Excellent boat for coastal/harbor fishing, or for lugging traps. Will send picture upon request. \$1,990.00 or BRO. 508 269-1406.

AD#13 (7/22) **FOR SALE** - Bronze dual ram steering Quadrant-Freeman Oval hatch-15x23 opening SS mast base. 2 2ft., outriggers-no base-Mike 978-745-6182 leave message.

AD#14 (11/22) **WANTED** – Double drum winch-45ft Boat-Call 978-283-2550.

AD#15 (9/22) **FOR SALE** – 12" Electra-dyne hauler & davit. \$1,800.00 John @ 617-750-3263.

AD#16 (9/22) **FOR SALE** – Fiberglass mold/Swampscott style square bow 10 ft. flat bottom work skiff \$950.00 Call- 978-578-8882.

AD#17 (12/22) **FOR SALE** – 200 used traps 13 1/2 x 21 1/2 x 39" \$25.00 per trap. Call 401-635-4371

AD#18 (10/22) **FOR SALE** – 24' Privateer, 5.7L Crusader low hours, Honda hydraulic power pack with 10" hauler. S.S. Davit. Plotter, sounder, radar, VHF. New cockpit floor & deck with 2' stern extension. Rigged for pot hauling. Ready to fish. \$16,000. Area 2 coastal Mass lobster permit, 90 pot allocation \$25,000. Selling as a package, boat & permit \$35,000. Located in Oak Bluffs. 774-563-0393.

AD#19 (8/22) **FOR SALE** – 200-LMA 2 EEZ/inshore dual zone trap tags \$27,000 Call - 508-542-5729.

AD#20 (11/22) **FOR SALE** - 1,000 hooks new tub trawl-gear W/anchors, 180 buoy lines. B.R.O. Bryan @ 508-221-8568.

AD#21 (11/22) **FOR SALE** - 1987 Daniels Head 39' 11" Fiberglass Gillnet boat. 207HP Mitsubishi D14.14 T Diesel engine (1992), Twin Disc 506 trans, complete electronics, 2 berth, 6'x5' aluminum gill net reel with stainless frame, 2 fish holds, 2 insulated deck boxes, rollers, 2 bus heaters, vessel in good condition – new fuel tank, new paint/fiberglass/fish boxes (2022). \$79,500 or B.R.O. Fed Permit Monkfish B with around 80 nets and 16 dog nets with buoy st anchors \$45,000. Federal directed shark permit \$15,000.- Call 609-294-1628 /text for pictures 609-713-5228 .

AD#22 (10/22) **FOR SALE** - Area 1 lobster permit, 800 pots-\$25,000.00 B.R.O. Call 774-283-2191.

AD#23 (8/22) **FOR SALE** - 100 traps 36x21x15 \$10.00 each Life Raft \$500.00 Call- 508-577-4868.

AD#24 (8/22) **FOR SALE** - LMA-1 Federal lobster permit, 800 trap allocation, good history \$38,000.00 978-578-8882.

AD#25 (9/22) **LINE FOR SALE** - 3-10 pot trawls of 7/16" Everson line-14 Fathom between traps-7/16" gangions-2 – 20 F x3/8" buoy lines-In totes

included -\$60.00 / trawl Joel @ 781 581 0324 or E-mail [joel.w.marie@gmail.com](mailto:joel.w.marie@gmail.com).

AD#26 (9/22) **FOR SALE** - 5" Superior hauling block-Aluminum construction with stainless sheave \$250.00 Joel @ 781 581 0324 or E-mail [joel.w.marie@gmail.com](mailto:joel.w.marie@gmail.com).

AD#27 (9/22) **FOR SALE** - Spare new stainless sheave for 5" Superior block-\$150.00 Joel @ 781-581-0324 or E-mail [joel.w.marie@gmail.com](mailto:joel.w.marie@gmail.com).

AD#28 (12/22) **FOR SALE** - two aluminum propellers 13.5x15 & 14x11 for Evinrude outboard were on 115 HP, great condition \$50. each Ipswich 978-356-4525.

AD#29 (9/22) **FOR SALE** - Area 2 lobster permit 128 tag limit \$21,000.00 774-775-2827.

AD#30 (9/22) **FOR SALE** - 22ft. Siso Lobster boat 150HP Evinrude OB needs work has 12" hydraulics hauler runs off Honda hydraulics power pack needs work & comes with trailer. Asking \$13,000.00 or B.O. Robert @ 5:00p.m. 617-846-3714 or 617-650-3842.

AD#31 (9/22) **FOR SALE** - #1 Bellhousing 2:1 gear reduction – re-built 51 14A – twin disc transmission- Down Angle-North Atlantic Power Products. 0- hours. 1000 hours or 6-months warranty. \$17,200.00 Peter @ 203-627-6070.

AD#32 (10/22) **FOR SALE** - Lobster Boat-1968 Novi fiber glassed over wood. John Deere 2011 Call for more info-978-290-9929 \$13,500.00.

AD#33 (12/22) **FOR SALE** - Mass conch license \$40,000 Call 508 496 5626

AD#34 (12/22) **FOR SALE** - 28.2ft boat, built in 1976 engine cat 3208, 265HP trans 2.1 twin disk fiberglass JC hull. Area 1 Coastal lobster permit 800 traps, 700 3ft lobster traps with rope and buoys. Call Joe 978-239-5927.

# CAT MARINE ENGINES

## Tier 3 Commercial Line-up

### C7.1



#### C7.1 Tier 3 Commercial Ratings:

280 HP @ 2300 Heavy Duty "B" **IN STOCK**  
350 HP @ 2500 Maximum Continuous Duty "C" **IN STOCK**  
400 HP @ 2600 Intermittent Duty "D" **IN STOCK**  
425 HP @ 2700 Intermittent Duty "D" **IN STOCK**

### C9.3



#### C9.3 Tier 3 Commercial Ratings:

375 HP @ 1800 Heavy Duty "B"  
416 HP @ 2100 Maximum Continuous Duty "C"  
476 HP @ 2300 Intermittent Duty "D"

### C18



#### C18 Tier 3 Commercial Ratings:

470 HP @ 1800 Continuous Duty "A"  
600 HP @ 1800 Continuous Duty "A"  
670 HP @ 1800-2100 Heavy Duty "B"  
715 HP @ 1800-2100 Maximum Continuous Duty "C"  
803 HP @ 2100 Intermittent Duty "D"

#### \* Tier 4 Exempt Light Commercial Ratings:

**1,001 BHP @ 2300**  
**1,136 BHP @ 2300**

### C32



#### C32 Tier 3 Commercial Ratings:

750 BHP @ 1600-1800  
800 BHP @ 1600-1800

#### AUTHORIZED MARINE DEALERS

**Billings Diesel & Marine Service**

*Stonington, ME*

**Dennis' Welding & Marine**

*Beals, ME*

**Front Street Shipyard**

*Belfast, ME*

**Lyman Morse at Wafarer Marine Corporation**

*Camden, ME*

**Journey's End**

*Rockland, ME*

**Fairhaven Shipyard & Marina, Inc.**

*Fairhaven, MA*

**Guy Crudele Repair**

*Gloucester, MA*

**Sacchetti Marine and Industrial LLC**

*Plymouth, MA*

**Windward Power Systems**

*Fairhaven, MA*

**DePaul Diesel Services, Inc.**

*Portsmouth, RI*

**Hinckley Yacht Service**

*Portsmouth, RI*

**Rhode Island Engine Company, Inc.**

*Narragansett, RI*

\*All T4 Exempt Light Commercial Ratings, require qualifications review and approval by CAT Factory.

\*Contact Nick Fawle or Your Authorized Marine Dealer for Tier 4 exemption qualification details.

For Marine Engine Sales, contact Nick Fawle, our new Marine Market Manager.

**Nick Fawle at 603-484-5248**

Nick\_Fawle@miltoncat.com

**Milton**



miltoncat.com

Massachusetts Lobstermen's Association  
8 Otis Place  
Scituate, MA 02066

PRSR STD  
U.S. POSTAGE  
PAID  
Permit 137  
New England Newspapers, Inc.



**Stock and Custom-Built Traps  
Lobster and Specialty Traps  
Aquaculture Supplies  
Huge Inventory of Commercial  
Fishing Supplies  
Four Locations in Maine**



**BROOKSTRAPMILL.COM  
(800) 426-4526**