



MASSACHUSETTS LOBSTERMEN'S ASSOCIATION

A LEADING Commercial Fishing Industry Association in New England



JOIN TODAY and
show your support

OCTOBER 2022 NEWSPAPER • WWW.LOBSTERMEN.COM

National Marine Fisheries Services Embarks on Phase 2 Planning to Reduce Risk by 90% Coastwide

During the several meetings of the Atlantic Large Whale Take Reduction Team (ALWTRT) it became quite clear the Phase 2 was clearly going to be the most shocking of them all as National Marine Fisheries Service (NMFS) revealed the worst case scenario of measures to reduce risk.

These presentations were nothing short of awe shocking to see a slew of measures that NMFS ran through the Decision Support Tool (DST). All of these “wish lists” are to reduce risk coastwide by 90% in the gillnet and Other Trap Pot (OTP) fisheries. These OTP fisheries include, conch/whelk and fish pots.

NMFS has recalculated and changed its assumptions being used in DST about the current fishing effort creating a “new” risk reduction scheme. The MA Bay Restricted Area during Phase 1 gave MA a 26% risk reduction credit and now under the new calculations it achieves a 15% risk reduction. This “new” recalculation has reduced the overall risk reduction credit given for MA State waters which is



now at 78% and not 92% as previously calculated during Phase 1.

Furthermore, during Phase 2 the risk reduction “wish list” measures that have been run

through the DST have covered everything from a 50% vertical line reduction to sprawling and expanded closures to achieve the coastwide 90% risk reduc-

tion goal. These risk reduction measures still leave Massachusetts carrying the utmost of risk reduction for the region.



SERIOUS ABOUT SAFETY

LRSE.COM | 401-816-5400

590 FISH RD, TIVERTON, RI 02878
 181 OLD COLONY AVE, UNIT A, BOSTON, MA 02127
 55 STATE ST, NARRAGANSETT, RI 02882



SALES • SERVICE • TRAINING • RENTAL • OUTFITTING • PICKUP + DELIVERY

Safety Equipment Servicing

Life Raft + Survival Equipment has been selling and servicing all major brands of Life Rafts, EPIRBs/PLBs, Life Jackets, Immersion Suits, and Man Overboard Equipment since 1983.

We offer pickup and delivery to over 20 locations throughout the Northeast.

CALL FOR GREAT PRICING.

North East Safety Training

NEST, a division of LRSE, offers hands-on Basic, Advanced, and Customized Safety Training Courses, Monthly Drill Conducting, First Aid/CPR/AED Courses and Vessel Inspections.

VISIT OUR WEBSITE TO LEARN MORE.

-  **LIFE RAFTS**
-  **EPIRBs + PLBs**
-  **LIFE JACKETS**
-  **IMMERSION SUITS**
-  **MAN OVERBOARD**
-  **PICKUP + DELIVERY**

COMMERCIAL LIFE RAFTS

Elliot, Zodiac, Crewsaver, Revere, Viking



FIBRELIGHT LADDERS

Man Overboard Recovery Cradle, Self Recovery Ladder



IMMERSION SUITS

Imperial



EPIRBs

ACR V4



FIRETKO®

Fire Suppression Tool



LIFE JACKETS

Mustang



MLA Sponsors

The following companies are proud supporting MLA members. We encourage our members to patronize them. If your company is not listed and you would like it to be, contact Tracey Abboud at 781-545-6984, ext. 2

ALIVE & KICKING LOBSTER
LOUIS MASTRANGELO
CAMBRIDGE, MA
617.876.0451

BAR HARBOR LOBSTER
JEFF HAZELL
ORLANDO, FL
407.851.4001

BOSTON LOBSTER
NEIL ZARELLA
617.464.1500
bostonlobstercompany.com

BOSTON SWORD & TUNA
STEPHEN SCOLA
BOSTON, MA
617.946.9850

BROOKS TRAP MILL
STEPHEN BROOKS
THOMASTON, ME
207.354.8763
stephen@brookstrapmill.com

CAPE ANN MARINE
SALES & SERVICE
978.283.0806
CapeAnnMarina.com

C-TRAP
MATT BORGES
MATTAPOISETT, MA
508.758.2740

CAPE SEAFOODS BAIT DEALER
GERRY O'NEIL
GLOUCESTER, MA
978.479.4642

CAPE FISHERMEN SUPPLY
DAVE LIBBY
CHATHAM, MA
508.945.3501

CAPE TIP SEAFOODS
CHRIS KING
PROVINCETOWN/ORLEANS
508.487.0259 | 508.225.7221

CAPTAIN MARDEN'S SEAFOODS
KIM MARDEN
WELLESLEY, MA
781.329.7007 | 781.329.0792
captainmardens.com

CHERRY ST. FISH MARKET
DARRYL PARKER
DANVERS, MA
978.777.3449

CHRIS ELECTRONICS CORP.
FAIRHAVEN, MA
508.994.8257

COASTAL HYDRAULICS
RICH TUCKER
SEABROOK, NH
603.474.1914
coastalhyd.com
sales@coastalhyd.com

COHASETT LOBSTER POUND
TOMMY ALIOTO
COHASETT, MA
781.383.1551

EAST COAST SEAFOOD
SPIROS TOURKAKIS
LYNN, MA
781.593.1737

ECKLAND & BLANDO
SAM BLATCHLEY
BOSTON, MA 02110
617.217.6936
www.ecklandblando.com

ELECTRA-DYNE CO INC.
JUDY MACCAFERRI
PLYMOUTH, MA
508.746.3270

FARM CREDIT EAST
MIDDLEBORO, MA
508.946.4455

FISHER AIR FASTENERS
ED & CHRIS FISHER
PEMBROKE, MA
781.826.2522

FISHERMEN SERVICES
DONNA CHEPREN
781.545.5073 Ext. 16
fishermenservices.com

FLEET PROPELLER SERVICE
MIKE VALM
FAIRHAVEN, MA
508.979.8000

FRIENDSHIP TRAP CO.
JERRY WADSWORTH
FRIENDSHIP, ME
800.451.1200

HAMILTON MARINE INC.
56 US ROUTE 1 BYPASS
KITTELY, ME 03904
207.439.1133
hamiltonmarine.com

HARBOR FUELS
info@harborfuels.com
617.720.3835

HERCULES
JOHN REARDON
NEW BEDFORD, MA
508.993.0010

JAMES HOOK & CO.
ED HOOK JR.
BOSTON, MA
617.423.5500

JOHN M. KARBOTT CUSTOM WOODEN BOAT BUILDING & REPAIR
PLYMOUTH, MA
508.224.3709
by-the-sea.com/
karbottboatbuilding

KETCHAM TRAPS
HEATHER KETCHAM
NEW BEDFORD, MA
508.997.4787

KINGFISHER TRAP
CARL HOWARD
DENNIS, MA
508.385.5968

KING LOBSTERS
D.J. KING
BRANFORD, CT
203.488.6926

KING MARINE LLC
CAPT. GEORDIE KING
MARINE SURVEYOR
207.337.8706
kinggeordie@comcast.net

LOBSTER CRUISES
PAUL QUINTAL
PLYMOUTH, MA
508.746.5342

LOBSTER TRAP FISH MARKET
MONUMET BEACH, MA
508.759.6400
lobstertrap.com

LOBSTER TRAP CO.
LOGAN CLARK
BOURNE, MA
508.759.4928
lobstertrap.com

LYNCH LOBSTER CO.
JOHN LYNCH
BEVERLY, MA
978.921.8088

MAIN STREET WIRE
DOUGLAS, MA
508.847.8888

MARINE HYDRAULIC ENGINEERING
ROBERT CROWE
ROCKLAND, ME
207.594.9525 | 800.747.7550

MILTON CAT POWER SYSTEMS
NICK FAWEL
MILFORD, MA
508.207.8542

MORTILLARO LOBSTER, INC.
VINCE MORTILLARO
GLOUCESTER, MA
798.281.0959

NAHANT FISH & LOBSTER
781.592.7500

NAPA-CAPE COD
BILL DRINAN
FALMOUTH, MA 508-457-1734

NAVROC MARINE ELECTRONICS
JASON PHILBROOK
ROCKLAND, ME
207.596.7803

N.E. MARINE & INDUSTRIAL INC.
MIKE RICHARDSON (NH)
603.436.2836 | 781.834.9301
Info@newenglandmarine.com

NEW ENGLAND PROPELLER
RON PECK
PLYMOUTH, MA
800.635.9504
nprop@aol.com

NORTH ATLANTIC POWER-TWIN DISC
SAM PROFIO
EXETER, NH
sprofio@glpower.com
603.418.0470

PIGEON COVE COOP
ROBERT MORRIS
978.479.3828

RFP LOBSTER BAIT
DICK PERENTZ
774.248.0292

RIVERDALE MILLS
NORTHBRIDGE, MA
508.234.8715

ROSES MARINE
MARTY BOLCOME
GLOUCESTER, MA
877.283.3334
rosesmarine.com

SEA CLIFF LOBSTER
FRANK COLLINS
MANOMET, MA
508.224.5700

SPURS MARINE MFG.
PABLO SOSA
FORT LAUDERDALE, FL
800.824.5372

SUPERIOR LOBSTER
MARSHFIELD-SANDWICH
774.773.5048
www.superiorlobster.com

THE NEW RESULT
LOUIS LARSEN
Mvseafood@vineyard.net

TWO COUSINS FISH MARKET
BRIAN O'DONOHUE
FREEPORT, NY
516.379.5065

WELLFLEET SHELLFISH CO.
508.255.5300
sales@wellfleetshell.com

WINDWARD POWER SYSTEMS
FAIRHAVEN, MA
774.992.0059
windwardpower.com

WOOD'S SEAFOOD
JAY KIMBALL
PLYMOUTH, MA
508.746.0261
www.woodseafood.com

YANKEE FISHERMEN'S CO-OP.
SEABROOK, NH
603.474.9850



**Published by the Massachusetts Lobstermen's Association, Inc.
8 Otis Place, Scituate, MA 02066**

– Published monthly –

Mailed to all paid members of the Massachusetts Lobstermen's Association

Newsletter Departments

Editor, Industry News, Notice Section, Editorial, Blog, Industry News, Promotions, Layout,
Advertising: **Beth Casoni – Executive Director** • Buy Sell Swap: **Tracey Abboud**

Newsletter Advertising Rates

The MLA Newsletter is published monthly
(Please note that all pre-paid ads for last year will be honored)

\$50 – ¼ Page Ad • \$80 – ½ Page Ad • \$110 – Full Page Ad • Color Ads – + \$50 per ad

The Massachusetts Lobstermen's Association will continue its efforts on your behalf to conserve the resource, protect your livelihood, keep you informed, promote the industry and provide you with increasing benefits as they are developed. MLA stands ready to help you in anyway, at anytime – just let us know how!
Safe on the water and good fishing!

**Make cleanup
easy and fast.**

Blast Away!

Onboard Pressure Washers
5.6 GPM @ 3,500 PSI

Our pressure washers come with everything you need, including 50' hose and wand with turbo nozzle.



Belt Driven

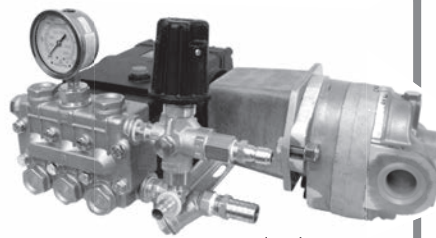

Hydraulic

Salt or Fresh Water

Coastal Hydraulics, Inc.

603-474-1914 • sales@coastalhyd.com

www.coastalhyd.com

28 Route 286, Seabrook, NH



THE Specialists
FROM BUOY TO TRAP

**Built the Best, Built to Last,
Built Your Way.**

PROVEN PERFORMERS! Rockbottom Runners



Our precision formulation and process has been refined over the years to provide the optimum balance of strength and flexibility... – and the wise test shows it

Over **20 YEARS** of fishing;

Well over **HALF A MILLION** sold



Could you do this with any other concrete runner?



**SOLID STEEL CORE
- TOUGH POLYMER
COATING**



Over **6 YEARS** of fishing.

Over a **QUARTER MILLION** sold



OCEAN-TESTED for years... aircraft carrier decking and pilings in the marine borer intense Panama Canal Zone.



The toughest species of junglewood we've found ... and the only kind we sell.

**We are constantly listening to our customers:
Your feedback + continuous improvement
= proven reliability**

Here to serve you!

Jerry Wadsworth (207) 542-0842 jerryw@friendshiptrap.com

Jimmy Emerson (207) 483-6555 jemerson@friendshiptrap.com

Mike Wadsworth (207) 542-0841 mikew@friendshiptrap.com

Friendship Office: (800) 451-1200; (207) 354-2545

Columbia Falls Office: (800) 339-6558

Visit our website: www.friendshiptrap.com



BOATLOADS of Marine Supplies

HAMILTON
has it!

HM45
YEARS
**HAMILTON
MARINE**
BOATERS' STORE™

**Everything
you need
(and more)
in one
place!**

Photo by Read Pate ©

**KITTERY
PORTLAND
ROCKLAND
SEARSPORT
SW HARBOR
JONESPORT**

Our inventory is a unique mix of traditional & the latest in marine technology. We stock a wide range of top marine manufacturers. We are your one-stop destination for all things boating and beyond.



 **800-639-2715**  **hamiltonmarine.com**



Service Provider for MLA Non-Profit Boat Protection Cooperative Ltd.

MLA's #1 Commercial Boating Insurance Provider

Agreed Hull Value – Protection & Indemnity

Crew Coverage - Extended Policy Limits - Chartering

Marina Floaters - Multiple Fisheries - Deductibles

Call now for a free quote 781-545-5073

or

Request a quote online at fishermenservices.com



As the HAULER TURNS

After last month's Atlantic Large Whale Take Reduction Team (ALWTRT) meetings it has become quite clear that the Northeast Lobster Trap/Pot fishery is in the cross-hairs yet again as more risk reduction is coming. After the recalculation of the Decision Support Tool (DST) Massachusetts is now at 78% in the risk reduction effort when before the recalculation Massachusetts was at 92%. Go figure, the goal post has been moved yet again.

Regardless of where the goal post is now, more has to be done and the amount of the total risk Massachusetts is to the right whales is 7.3%, how much more can you do to further reduce risk? Even if ALL of the end-lines are out of the water in Massachusetts, the risk is still there and the commercial lobstermen in Massachusetts would be asked to do more, something smells fishy here.

Think about everything you are doing to reduce risk; massive closures, weak contrivances, trawling up, and so on. What can you do; Can you fish longer trawls? Can

you fish with 100% weak line? Can you fish with a 6-month closure? Can you fish 250 or 400 lobster traps? Can you fish with 75% weak line? Can you fish with one end-line? Can you fish? Can you fish? Can you fish? I am still in shock after listening to these various proposals that were being thrown around like it was all well and good. Good for who.... not you, who want to go to work and fish.

I cannot stress it enough; this fall NOAA will be holding Public Hearings on the risk reduction proposals. These proposals will determine where, when and what the risk reduction measures will be and, if you are not at the Public Hearings you may find yourself on the outside looking at a 6-month closure and fishing 250 pots for six months. This is not the time to stick your head in the sand, just ask the lobstermen of the original MA Restricted Area Closure that was implemented in 2015.

Even with ALL of the risk reduction that Massachusetts commercial lobstermen have done, it's still not

enough. After participating in the ALWTRT meetings last month, there is no area in the Northeast Lobster Trap/Pot fishery that will get a pass and not be required to do more to reduce risk to the right whales. PLEASE participate during the fall Public Hearings and comment as the MLA will be there every step of the way.

I have to say this is mind-boggling as the stress levels are through the roof all around in the commercial lobster fishery here in the Commonwealth as more is being asked with no end in sight. When will enough be enough? Stay tuned!

The MLA is always looking for ways to help you offset the increased expense of the weak contrivances and earlier this year the Lobster Foundation of Massachusetts in partnership with the MLA was awarded a Massachusetts Environmental Trust, Drive for a Better Environment Grants Program. The Grant will help the LFoM purchase several hundred coils of the weak red and candy cane 1700lbs. rope with the



MASS LOBSTER tracer ribbon as well as holding several splicing classes. One of the goals of the project is to help reduce the use of knots in end-lines. More information will be forthcoming as we will be holding these classes in February – April, 2023.

If you do not receive MLA Members emails from me please send an email to beth.casoni@lobstermen.com and ask to be added to the MLA Members email list.

Safe on the water,

Beth Casoni

Director

IN MEMORIAL

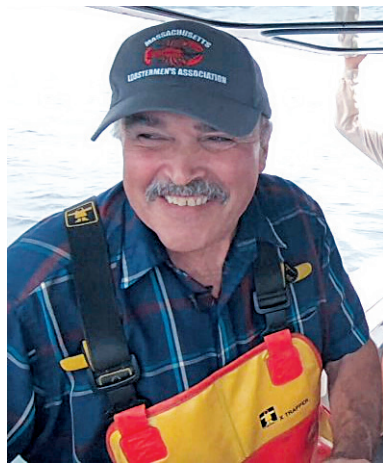

Bill C. Chaprales

SEPTEMBER 3 1951 - SEPTEMBER 18 2022

It is with heavy heart that we must tell you, MLA Delegate and lifelong MLA member, Bill Chaprales passed away unexpectedly on September 18, 2022. Bill was a dotting husband, loving father, dedicated papa. Burial at sea will be private. May you sail on calms seas with fare winds at your back. In lieu of flowers please donate to St. Judes Research Hospital: <https://www.stjude.org/donate/donate-to-st-jude.html>

The Atlantic States Marine Fisheries Commission's 80th Annual Meeting

The Atlantic States Marine Fisheries Commission's 80th Annual Meeting will be held November 7-10, 2022 at the Ocean Place Resort, 1 Ocean Boulevard, Long Branch, New Jersey. This will be a hybrid meeting to allow for remote participation by Commissioners and interested stakeholders in all meetings except for those of the Law Enforcement Committee, Habitat Committee and Atlantic Coastal Fish Habitat Partnership Steering Committee.



The American Lobster Management Board will be meeting on Monday November 7th at 9:45 - 11:45 a.m. to discuss and consider the following; • Update on North Atlantic Right Whale Court Cases • Consider Annual Data Update of American

Lobster Indices • Consider Next Steps on Draft Addendum XXVII on Increasing Protection of Spawning Stock Biomass of the Gulf of Maine/Georges Bank Stock • Update from Work Group on Implementation of Addendum XXIX on Electronic Vessel Tracking for Federal Permit Holders • Discuss the Trap Transfer Tax for the American Lobster Fishery • Progress Update on Jonah Crab Benchmark Stock Assessment • Consider Fishery Management Plan Reviews and State Compliance for America Lobster and Jonah Crab for 2021 Fishing Year.

If you would like to register to attend the meeting, please visit <http://www.asmfc.org/home/2022-annual-meeting>



Encore Hartco Tools & Clips
Stanley Spenax Tools & C-Rings
Wematic Tools & D-Rings
Simonds Pneumatic Wire Cutters
Spotnail Staplers & Staples



(781) 826-2522
Fax (781) 826 5252
www.fisherairfasteners.com
chris@fisherairfasteners.com

Complete Parts Inventory
Tool Repair Service



MARINE • FISHING GEAR • SAFETY

44 South Street, New Bedford, MA 02740
 Phone: 508-993-0010 Fax: 508-993-9005
Securing – Lifting - Rigging
 82 MacArthur Dr. New Bedford, MA 02740
 Phone: 508-992-9519 Fax: 508-992-9419

JohnReardon@Hercules-SLR-US.com

USCG Safety Inspection Station #327

Commercial Fishing-Marine Safety-Rigging

- ❖ Marine Hardware
- ❖ Cotesi - Netting, Leaded/Sink Rope
- ❖ Stormline & Climate Technical-Foul Weather Gear
- ❖ Buoys & Floats
- ❖ Lobster Bands
- ❖ PFD's, Vests, Float Coats
- ❖ Fish Totes
- ❖ Insulated Tubs
- ❖ Cordage & Twine
- ❖ Mooring Equipment
- ❖ Boarding Ladders
- ❖ Polysteel Rope- Esterpro Sinking, Hydropro
- ❖ Leadline
- ❖ Wire Rope - FC Galv, IWRC, Dyform
- ❖ HiFlyers 12', 14' & 15' XHD
- ❖ Golf & Batting Cage Netting



Inflatable PFD's



Life Raft Sales

- ❖ Revere
 - ❖ Elliot
 - ❖ Survitec
 - ❖ Switlik
- All brands accepted for service



Fenders & Buoys-All Colors



ACR Electronics
 Sales & Service
 for your E.P.I.R.B.



Boots from
 Honeywell Safety

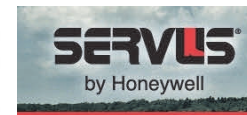

On-Board Vessel Inspections & Safety Drills

Call our USCG Certified Drill Conductors:

Rodney Avila 508-889-0401

Ted Williams 508-264-5779



Imperial
 Survival Suits
 Sales & Annual
 Inspections
 Done in house

AQUAMESH[®]

by Riverdale Mills



Can't get Aquamesh[®]? Call us!



1.508.234.8400 | 1.800.762.6374
sales@riverdale.com | www.riverdale.com



Atlantic States Marine Fisheries Commission NEWS RELEASE

FOR IMMEDIATE RELEASE: September 2, 2022 | PRESS CONTACT: Tina Berger, 703.842.0749

ASMFC Releases Request for Applications for Type Approval for American Lobster & Jonah Crab Electronic Vessel Tracking Devices



Arlington, VA – The Atlantic States Marine Fisheries Commission (Commission) is seeking applications for type approval of electronic vessel tracking devices (devices) for federally permitted American lobster and Jonah crab fishing vessels. Specifically, the Commission will approve a list of vendor(s)/device(s) in which

state agencies and the Commission can order in bulk, or fishing industry members can purchase individually to meet the requirements of Addendum XXIX to the American Lobster Fishery Management Plan (FMP) and Addendum IV to the Jonah Crab FMP. High quality devices are fundamental for many critical monitor-

ing and enforcement activities in the federal American lobster and Jonah crab trap fishery and the Commission anticipates over 1,700 devices will be needed. Some vessels will start to install devices prior to the beginning of the 2023 fishing year (May 1 start date), but all federal American lobster and Jonah crab trap vessels will be required to have installed a fully operational device by December 15, 2023.

Federal lobster and Jonah crab vessels issued commercial trap gear area permits will be required to install an approved device to collect and transmit spatial data in order to participate in the trap gear fishery. This means any federally-permitted vessel without an approved device will be prohibited from landing lobster or Jonah crab taken with trap gear. Federal vessels are required to install and activate an approved device prior to beginning a lobster or Jonah crab fishing trip with trap gear. The device must remain on board the ves-

sel and powered at all times when the vessel is in the water, unless the device is authorized to power down by the principal port state. For this reason, timely and accurate production and delivery of devices is of critical importance, and the approved vendor(s)/ device(s) must be capable of ensuring the Commission's performance standards will consistently be met.

The RFA can be found at http://www.asmfc.org/files/RFA/VesselTrackerRFA_Sept2022.pdf. The RFA, as well as the Question & Answer Summary and all amendments related to the RFA, can also be found at <http://www.asmfc.org/jobs/>. Applications must be submitted to the Commission, via email, at: LAubart@asmfc.org. Application submissions must be received no later than **11:59 p.m., local time, on October 3, 2022**. Applications not submitted to the Commission's aforementioned email address by the aforementioned deadline will not be considered for device type approval.

The Atlantic States Marine Fisheries Commission was formed by the 15 Atlantic coastal states in 1942 for the promotion and protection of coastal fishery resources. The Commission serves as a deliberative body of the Atlantic coastal states, coordinating the conservation and management of nearshore fishery resources, including marine, shell and diadromous species.

1050 N. Highland Street • Suite 200A-N • Arlington, VA 22201 • 703.842.0740 (phone) • www.asmfc.org



The Massachusetts Commercial Lobster Fishery “The Right Way”

Over the last 30 years, the Massachusetts Lobster industry has been at the forefront on right whale conservation measures while working vigorously to further protect the species. The 30 years of conservation measures have come at the expense of the commercial lobstermen and yet, they are still at the table looking for more ways to reduce risk.

Recently, the Monterey Bay Aquarium's (MBA) Seafood Watch program added the *American Lobster* to its “Red List” of seafoods to avoid. **This recent listing is neither warranted nor supported by the data here in Massachusetts.** Massachusetts commercial lobstermen are mandated to a 100% reporting threshold and the Massachusetts Division of Marine Fisheries has 30 plus years of data necessary to debunk why Massachusetts lobster should not be on this “Red List”. **This listing is misleading to the general public and should be retracted immediately.**

Massachusetts commercial lobstermen are 30 years ahead of the rest of the region when it comes to reducing risk to the right whales. Massachusetts is the leader in conservation as Senator Edward Markey recently commented that, *“The North Atlantic right whale is in crisis, and a unified effort is needed to prevent the extinction of this endangered species. Massachusetts Lobstermen know this issue, care about this issue, and have remained committed to doing their part despite regulations that entail major sacrifices by the industry. Massachusetts has achieved 97% in harm reduction in our state waters and I encourage other states to do the same.”*

Massachusetts is doing more than any other state or region for the protection of right whales all the while maintaining a sustainable resource and profitable commercial lobster fishery. **The Massachusetts *American Lobster* should be listed on the “Green List” of seafoods to buy.** Massachusetts Senator Elizabeth Warren recently commented that, *“Massachusetts lobstermen and fishing families have always been strong stewards of the ocean, shouldering much of the burden to help protect the North Atlantic right whale while working collaboratively with scientists to find creative solutions. The severity of this crisis demands urgent action from all stakeholders, and I’m confident that Massachusetts will continue doing its part to make the oceans safe for endangered right whales”.*

Furthermore, there have been ZERO Right Whale deaths attributed to Massachusetts Lobster gear and the MBA’s conclusion snubs all of the right whale conservation efforts that Massachusetts commercial lobstermen have implemented such as:

- 1935 - International ban on hunting whales goes into effect
- 1970 - North Atlantic Right Whales listed as endangered
- 1996 - NOAA implements the Large Whale Take Reduction Plan
- 1997 - MA requirement for “breakaway” features in gillnets and trap/pot buoy lines Seasonal ban in Cape Cod Bay for gillnets and on use of floating rope between traps, dedicated aerial surveys begin in Cape Cod Bay



2004 - First in Nation for year-round ban on floating rope between traps in Cape Cod Bay (9,000 miles removed)

2007 - First in Nation for year-round ban on use of floating rope between traps statewide

2014 - First in Nation - MA Restricted Area is created – 3-month closure Feb-April to 3,071 sq. miles

2015 - 3 month (Feb/Apr) closure to all pots/traps in the MA Restricted Area

2016 - 3 months (Feb/Apr) closure to all pots/traps in the MA Restricted Area

2017 - 3 month (Feb/Apr) closure to all pots/traps in the MA Restricted Area PLUS 4-day extension of the gear closure in Cape Cod Bay

2018 - 3 month (Feb/Apr) closure to all pots/traps in the MA Restricted Area PLUS a 15-day extension of the gear closure and speed restriction (10 mph) for small vessels in Cape Cod Bay

2019 - 3 month (Feb/Apr) closure to all pots/traps in the MA Restricted Area

2020 - 3 month (Feb/Apr) closure to all pots/traps in the MA Restricted Area

2021 - 3 (Feb/Apr) closure to all pots/traps in the MA Restricted Area PLUS a 15-day extension of the gear closure and speed restriction (10 mph) for small vessels in Cape Cod Bay

2022 - Southern N.E. closed 5,648 sq. miles est. right whale population 350. Making the total sq. miles 11,722 closed to lobstering.

Over the last 5 years, the Massachusetts Lobster Foundation in collaboration with the Massachusetts Lobstermen's Association and Ketcham Trap developed weaker red and candy cane rope breaking at 1,700 lbs., with a MASS LOBSTER tracer ribbon.

The commercial lobstermen in Massachusetts have been fishing this weakened rope for 4 years now without many issues. We are working with Ketcham Trap on every iteration to make it a little better but still weak to keep the fishermen fishing.

The Massachusetts Environmental Trust, Drive for a better environment, provided grant

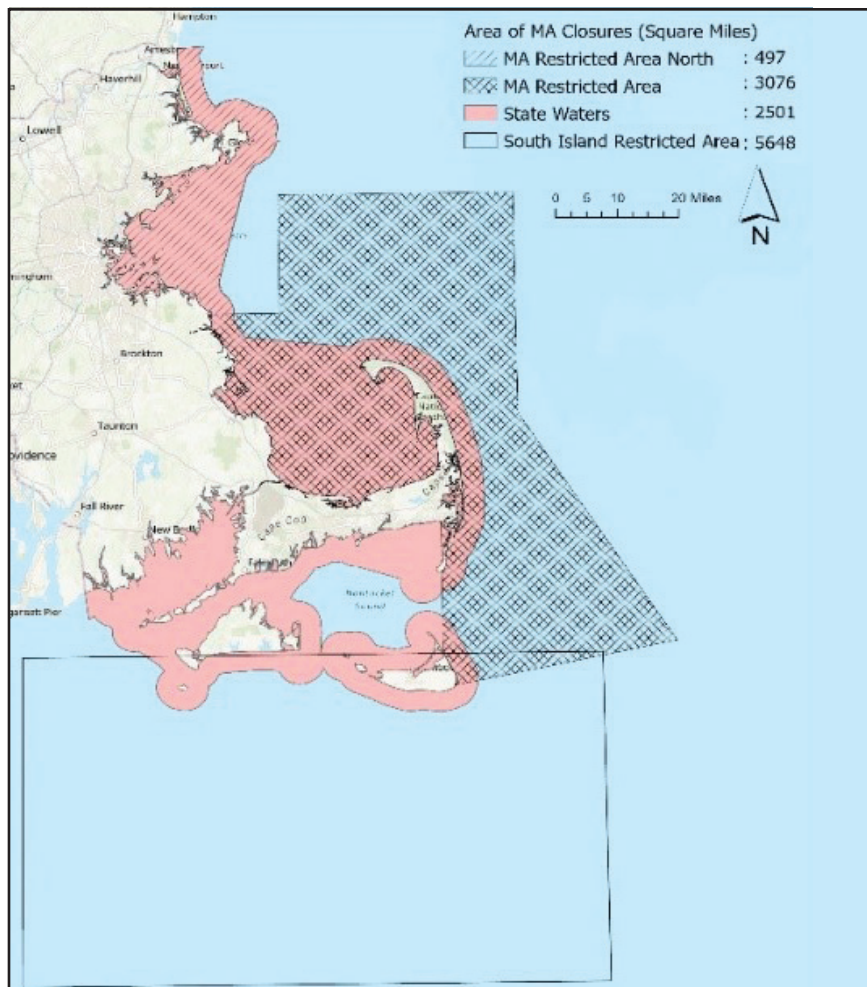

funding to further Massachusetts commercial lobstermen’s conservation efforts on behalf of right whales and all whale species.

Massachusetts is doing more than any other state or region for the protection of right whales! Massachusetts Lobster should be listed on the “Green List” of seafoods to buy. Proud to sup-

port our #MassachusettsLobstermen who lead the nation in right whale conservation.

To learn more about all of the Massachusetts right whale conservation measures, please visit the Lobster Foundation of Massachusetts at www.lobsterfoundationofma.org

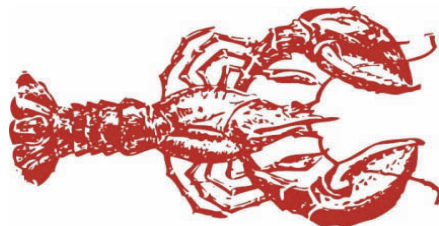

“Specializing in the sale & delivery of **LOBSTER BAIT** for over 30 years”

FRESH FROZEN AND SALTED BAIT AVAILABLE

**SKATES ~ HERRING ~ POGIES ~ HADDOCK ~ COD FISH ~ POLLOCK
FLAT FISH ~ FISH SKINS ~ RED FISH ~ DOG FISH HEADS ~ SALMON**



C & P BAIT
33 Wright St
New Bedford, MA 02740

Contact:
Danny Costa 508-951-9818
Carlos Pereira 508-951-9819



New England Marine & Industrial
www.newenglandmarine.com

Lobster Bands

We carry:

Sheddar

Standard

Cold Water Shedder

Jumbo



Buy them by the 1 pound bag, by the case or by the pallet. We also offer wholesale and volume discounts. Call and ask to speak to a salesman.



Dayglo &
Flexabar
Buoy Paint



Perone Buoys

Full selection of sizes
in Stock

Riverdale/Aquamesh Trap Wire

- Large inventory of trap wire in store
- Variety of sizes and colors available
 - Some trap kits in stock
- Order any size trap kits you may need

200 Spaulding Tpke
Portsmouth, NH
603-436-2836

294 Ocean St
Brant Rock, MA
781-834-9301

86 Cemetary Rd
Stonington, ME
207-367-2692



DECKHAND™

Join our Deckhand® Beta Crew!

Commercial fishermen are the most important group to ensure Deckhand Pro keeps getting better. If you're interested in being at the cutting edge of our electronic logbook technology to help make positive impacts in product development, we want you on our Beta Crew!

Being a Beta Crewmember means:

- You get advance copies of products and features before release to the public;
- You get priority attention from our support crew;
- You get to contribute ideas or changes to our product that will help us make the product better for you and others;
- You get free subscriptions to Deckhand® Pro In-App Purchases while testing, and **a free lifetime subscription to the logbook of your choice after being on the Beta Crew in good standing for 6 months!** **Offer available for a limited time!**

Deckhand Pro runs on Apple iPad (WiFi+Cellular) and almost any recent model is fully supported.

If you already have an Apple iPad...

Apply to be a Beta Crewmember with the following steps:

1. First, call us at 888-210-3117 and select option 1 or send an email to beta-request@deckhandlogbook.com.
2. We'd like your name, information about your commercial fishing activity, fishery, and vessel that will help us assure your request is approved quickly.
3. Expect to hear from us within 1 business day. All the information you need to start testing will be included when we reply!

If you don't have an Apple iPad, but are still interested in the Beta Crew:

Depending upon your circumstances, we may be able to provide an iPad for a limited time with a small deposit, especially if you are a member of a fishing organization or other group evaluating our product for use. Again, please send an email to the above email address or call us. We may have some additional questions or information we need to exchange for situations where an iPad is provided.

We look forward to welcoming you to the Deckhand Beta Crew!

*Multiple In-App Purchase options may be available at any time. Beta Crewmembers in good standing after 6 months will be able to choose one (1) IAP product for a lifetime subscription. This offer is subject to availability and Beta Crew program enrollment/capacity, and may change at any time.

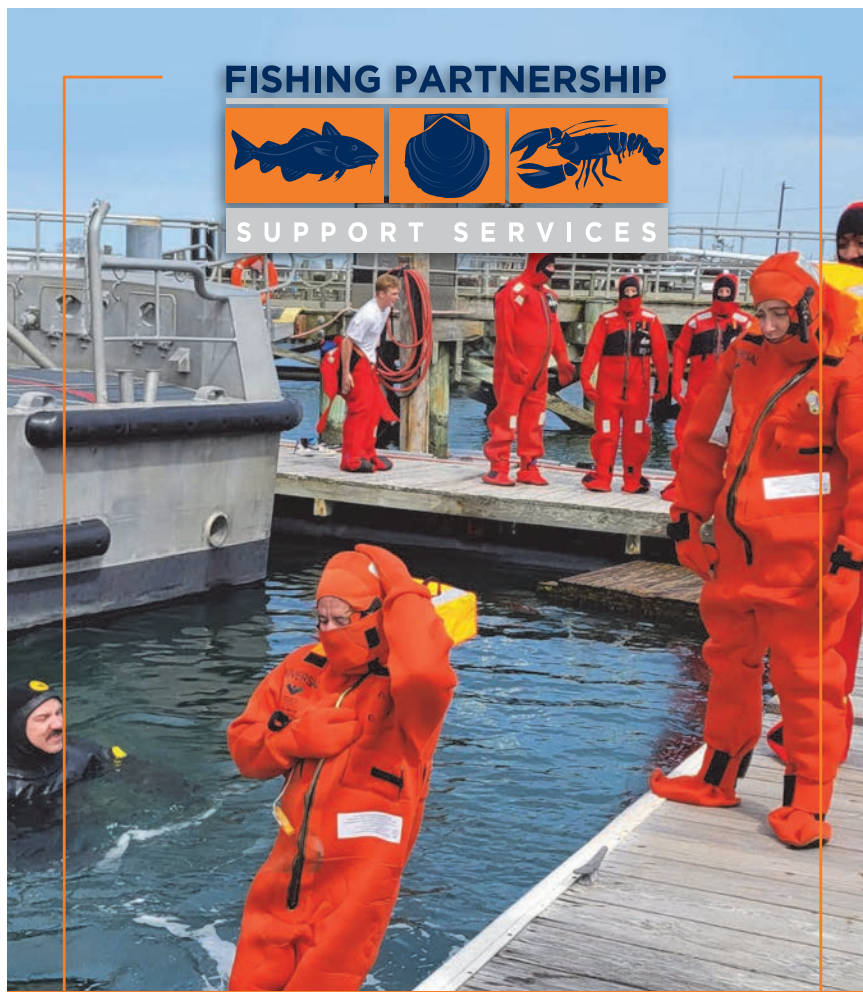

FISHING PARTNERSHIP



SUPPORT SERVICES

Mission

To improve the health, safety and economic security of commercial fishermen and their families.

Fishing Partnership is here to help MA residents access affordable health coverage. Contact a certified Navigator today for assistance with updating an application or finding a new plan for 2023. Existing Health Connector/MassHealth members should respond to notices they receive and call a Navigator to explore all their options.

NAVIGATOR OFFICES:

Gloucester 978-282-4847	Plymouth 508-746-5400
New Bedford 508-991-3043	Chatham 774-840-9393

Massachusetts maintains a mandate for all individuals to have health insurance. Unenrolled residents could pay a tax penalty. Don't risk it – call a Navigator and get covered today!

Follow



617-928-3443
fishingpartnership.org





Atlantic States Marine Fisheries Commission

1050 N. Highland Street • Suite 200A-N • Arlington, VA 22201

703.842.0740 • 703.842.0741 (fax) • www.asmf.org

MEMORANDUM

TO: Atlantic Herring Management Board, Atlantic Herring Technical Committee, Atlantic Herring Advisory Panel, Interested Parties

FROM: Toni Kerns, Policy Director *TK*

DATE: September 14, 2022

SUBJECT: Days Out Measures for Season 2 of the 2022 Atlantic Herring Area 1A Fishery; Western Maine and Massachusetts/New Hampshire Spawning Closures in Effect Starting September 23, 2022 through November 3, 2022

This memorandum announces days out measures for the 2022 Area 1A (inshore Gulf of Maine) Atlantic herring fishery for Season 2 (October 1 – December 31); and closure dates for the Western Maine and Massachusetts/New Hampshire spawning areas.

Landing Days for the 2022 Area 1A Fishery for Season 2

The Atlantic States Marine Fisheries Commission's Atlantic Herring Management Board members from Maine, New Hampshire, and Massachusetts met September 14 via conference call to set effort control measures for the 2022 Area 1A fishery for Season 2 (October 1 – December 31). The Season 2 quota is approximately 174 metric tons (mt), which is 27.2% of the Area 1A sub-annual catch limit (ACL) after adjusting for the 30 mt fixed gear set-aside, a slight overage from Season 1, and an 8% buffer (since the Area 1A closes at 92% of the sub-ACL). This does not take into account the possible reallocation of 1,000 mt to the Area 1A sub-ACL based on catch information from the Canadian New Brunswick weir fishery.

Due to the very low quota, the days out measures for Season 2 are as follows:

- Landing days will be set at zero (0) for Season 2.
- If 1,000 mt is reallocated from the Canadian weir fishery to the Area 1A sub-ACL, the fishery will move to four (4) consecutive landing days starting Sunday, November 6 at 6:00 p.m. Landing days would begin on Sunday of each week at 6:00 p.m. starting November 6.

If the quota reallocation from the Canadian weir fishery occurs prior to October 21 or after November 7, the states will schedule an other days-out meeting.

While landing days are set at zero (0), harvesters are prohibited from landing more than 2,000 pounds of Atlantic herring per trip from Area 1A during Season 2.

Spawning Area Closures

The Atlantic herring Area 1A fishery regulations include seasonal spawning closures for portions of state and federal waters in Eastern Maine, Western Maine and Massachusetts/New Hampshire. The Commission's Atlantic Herring Management Board approved a forecasting method that relies upon at least three samples, each containing at least 25 female herring in gonadal stages III-V, to trigger a spawning closure. However, if sufficient samples are not available then closures will begin on predetermined dates.

There are currently insufficient samples from both the Western Maine spawning area and the Massachusetts/New Hampshire spawning area. Therefore, per Addendum II default closure dates, the Western Maine and Massachusetts/New Hampshire spawning areas will be closed starting at 12:01 a.m. on September 23, 2022 extending through 11:59 p.m. on November 3, 2022. The Western Maine spawning area includes all waters bounded by the following coordinates:

43° 30' N	Maine coast
43° 30' N	68° 54.5' W
43° 48' N	68° 20' W
North to Maine coast at 68° 20' W	

The Massachusetts/New Hampshire spawning area includes all waters bounded by the Massachusetts, New Hampshire and Maine coasts, and 43° 30' N and 70° 00' W.

Vessels in the directed Atlantic herring fishery cannot take, land or possess Atlantic herring caught in either the Western Maine or Massachusetts/New Hampshire spawning areas during this time and must have all fishing gear stowed when transiting through the area. The incidental bycatch allowance of up to 2,000 pounds of Atlantic herring per trip per day applies to vessels in non-directed fisheries that are fishing within the Western Maine or Massachusetts/ New Hampshire spawning areas.

Please contact Emilie Franke, Fishery Management Plan Coordinator, at efranke@asmfc.org or 703.842.0740 for more information.

Days Out Meeting Motions (September 14, 2022)

Move to set zero landing days for Season 2. If 1,000 mt is reallocated from the Canadian weir fishery to the US Area 1A sub-ACL, the fishery shall open at 6PM on Sunday, November 6 with four landing days (Monday thru Thursday). Should the reallocation of 1000mt happen prior to October 21 or after November 7, the states will schedule another days-out meeting. Motion by Ms. Griffin, second by Mr. Abbott. Motion passed by consent.



New England Marine Engineering & Supply, Inc.

Marine • Industrial • Commercial • Refrigeration

10 TON ELECTRIC TITANIUM RSW
INTEGRATED MARINE SYSTEMS

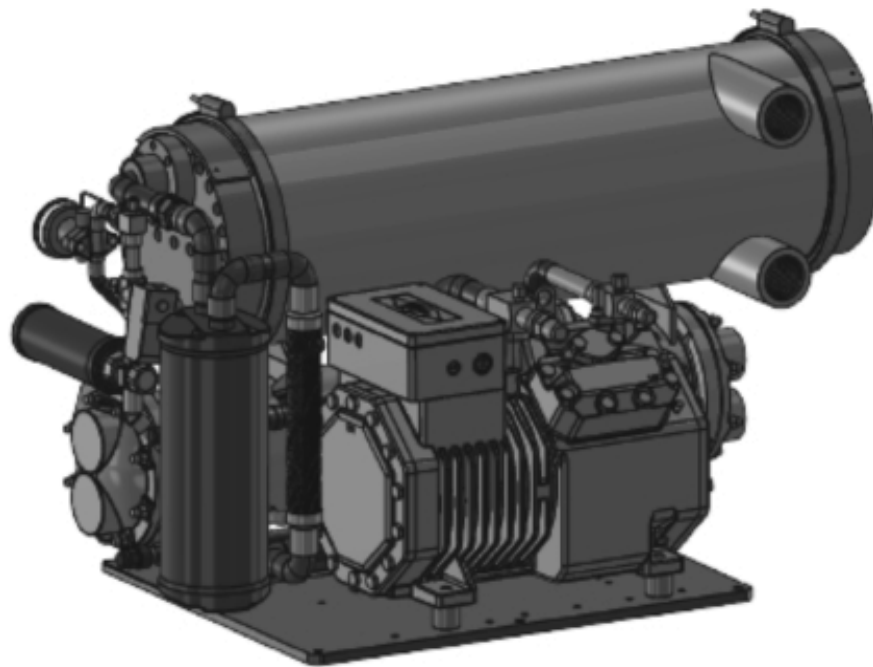

"New England Marine Engineering & Supply, Inc & Integrated Marine Systems, Inc is proud to announce & debut the new IMS 10 Ton Titanium Electric RSW at the 2018 Seafood Processing North America Show on March 11-13 Booth 1875. Come see us and be the first to view the latest IMS system to be introduced to the industry for the fishing vessels ranging from 40' - 80'.

It's going to be the talk of the show."

133 North Front Street, New Bedford, MA. 02740

www.nemesinc.com 1.800.540.8893



Cape Seafoods Bait Shop Kicking off the Season!

THE LARGEST BAIT VARIETY IN THE ATLANTIC NORTHEAST

In operation since 2001 and still going strong!

Trust Us for Your Fresh, Salted & Frozen Bait Needs

From (1) Carton to a Full Truck Load.

**Herring, Mackerel, Pogies, Redfish, Rockfish, Tuna, Monkfish, Sardines,
Plaice, Squid, Sea Robin, Halibut, & Silversides.**

We've got you covered!

Great News...We now buy Lobster, too!

Open Year Round (Serving clients 7 Days a Week from Mid-June To Mid-October)

Monday-Friday 5AM-3PM, Saturday 6AM-12PM & Sunday 6AM-10AM

Main Phone Line: 978.283.8522

Bait Shop Phone Line : 978.479.4642

If we don't have it... Please ask and we'll find it!

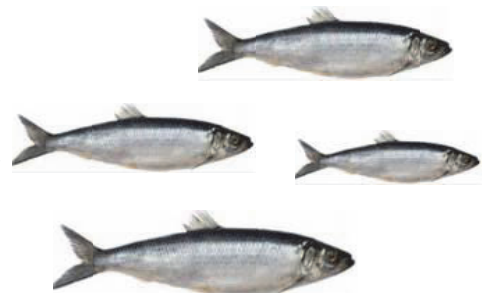



The MLA's Procrastinators Club Notice

Before we press the final "delete, erase, cancel" "obliterate" button on our Pac-man deluxe computer machine, here's one last chance to renew your membership with the MLA, this State's major voice for the commercial lobster industry in Massachusetts.

MLA news, member discounts, the boat insurance program etc. and most importantly representation for you on all lobster industry issues are at stake here. Why would you not want to have the Association working for you while you go out to fish everyday?

Please remember that if you are a Delegate or your boat is insured with the MLANPBPC, you must remain a member in good standing with the MLA.

There are multiple ways you can now pay your dues; over the phone at 781-545-6984 ext. 2, online at www.lobstermen.com or mail a check to MLA, 8 Otis Place, Scituate, MA 02066 or better yet stop by the MLA office.

PLEASE NOTE NOVEMBER WILL BE YOUR LAST NEWSPAPER UNTIL YOUR DUES ARE PAID IN FULL.

OVER 20 YEARS EXPERIENCE ~ ALL MATERIALS & SIZES



**FOR FAST SERVICE
CALL MIKE @
508.979.8000**

marine.propeller128@gmail.com

MARINE
PROPELLER SERVICE

REPAIRS &
RECONDITIONING
(Fast & Fully Insured)

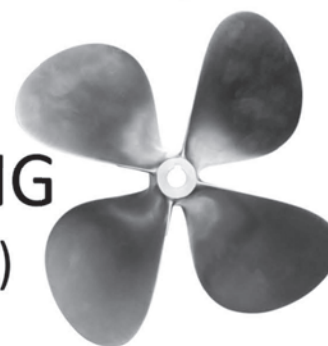

THE MOST RELIABLE PROPELLER SERVICE COMPANY ON THE SOUTHCOAST

74 MAIN STREET FAIRHAVEN MA 02719 508.979.8000 FAX 774.206.6449





Phase 2

FROM PAGE 1

With NMFS relying more and more on the DST, the uncertainty in the DST currently being used does not give anyone in the fishing industry a good feeling. NMFS needs to change the baseline years from 2015-2019 to 2017-2021 as the current data will paint a different picture in the overall risk reduction DST in the fisheries favor. NMFS also needs to have the DST Peer Reviewed and accepted first before the livelihoods of thousands of lobstermen are devastated.

Unfortunately, the North East Lobster Fishery (NELF) is not out of the risk reduction woods yet, as the lion's share of risk is still within the NELF. The percentage of risk

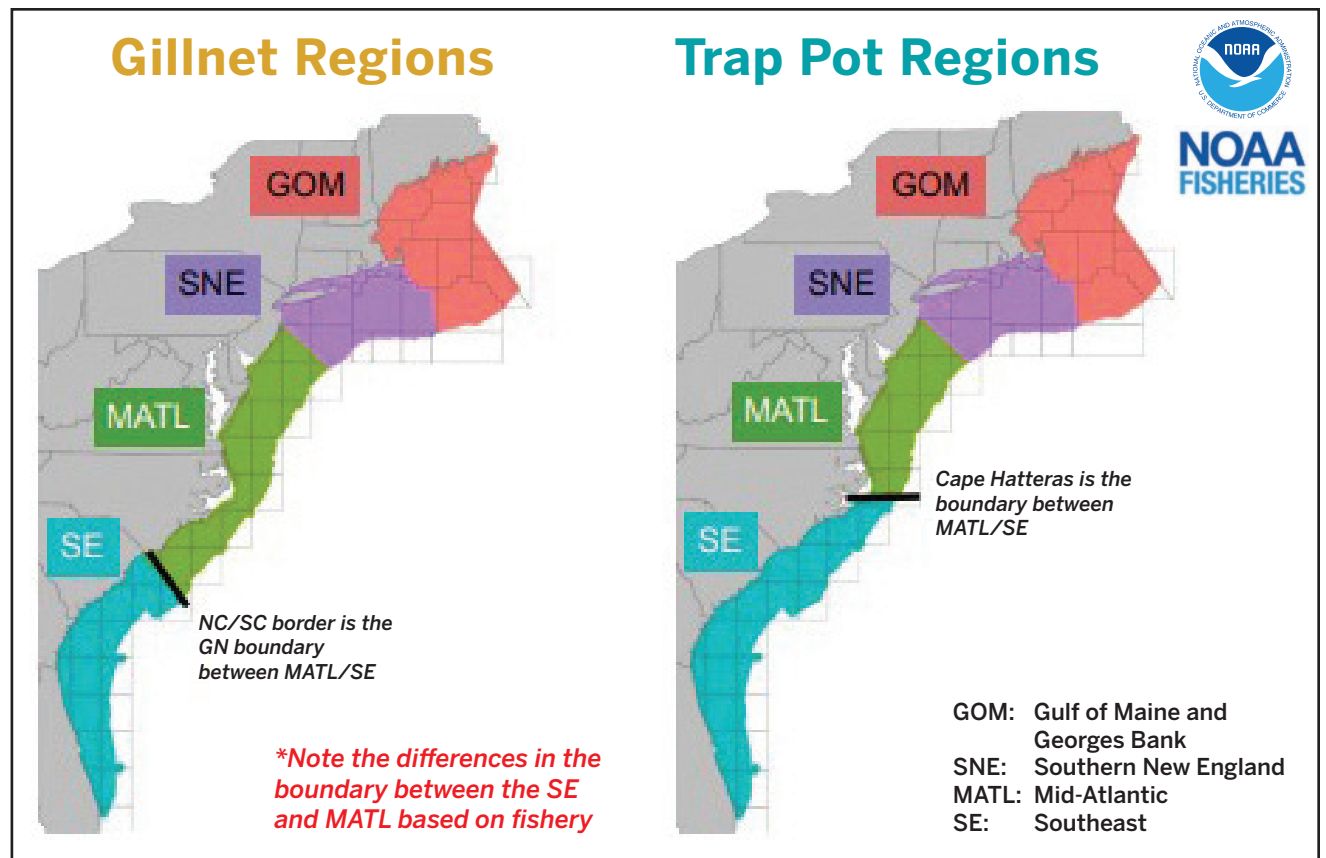

that Massachusetts has left overall is **7.3%**. Massachusetts over the last 8 years has

taken on the most draconian risk reduction measures anywhere. How much more risk

can be garnished from Massachusetts to save the North East Lobster Fishery?

Checking the Pulse on the 2022 Lobster Season



As the 2022 commercial lobster season in Massachusetts rolls on into fall, the catch is picking up and so is the price. After the slow

start earlier this spring and cost of doing business at an all-time high, these higher prices are surly welcomed. While these prices are not likely to reach the 2021 prices, they are better than what most regions are getting paid.

There have been a lot of calls and questions on why this year was slow to start and why did the price not reach the 2021 levels and after asking around, it all comes down to supply and demand. The supply was depleted in the processor/dealer freezers in 2020-2021 and they need inventory so they were willing to pay the higher prices.

Supply and demand are relative to the stock assessment and effort as they both give insight to what the end of the year will look like. After you review your catch vs.

expenses you can see how good your year was and the stock assessment, while they are not done every year, this is a good indicator as to how good the next 5 years or so will be relative to your catch.

NOAA stated that “since 2012, Young of Year surveys in the Gulf of Maine and George’s Bank stock have shown consistent declines, which could indicate future declines in recruitment and landings.” Seeing that it takes 7-8 years for a lobster to reach a harvestable size, is this what lobstermen are now seeing reflective in the catch? More to be revealed after the 2022 season is done.

More questions arose when the season was slow to start and the main one that really has a lot of lobstermen concerned is the increase in effort from other regions

with no end in sight. Here is one question that continues to come up: Should all regions make the lobster permit a “Limited Entry” to ease the effort on the resource? As Massachusetts is a “LIMITED ENTRY” fishery with NO new permits being issued and the effort in Massachusetts has dramatically declined to an estimated 845 active commercial lobstermen. The effort on one resource needs to be right sized before the bottom falls out.

Overall, the hundreds of millions of pounds of lobsters that have been landed in the U.S. between 2020-2021 are being purchased, shipped, processed, and eaten as the demand for your lobsters has not changed. Let’s see how the 2022 lobster season will shake out and if anyone is returning your lobsters!

Steve's Rope Splicing

Custom Rope Splices

BUOY LINE MARKING INSERTS

Massachusetts Vertical Line Solid Top Mark

NOAA & DMF Approved

20" Loop for easy attachment to buoy end

Removable Green Federal Marking

\$8

1200' Spools of
Red & Green
3/8" Poly

\$145

978-879-9737

StevesRopeSplicing@Gmail.Com

Gloucester, MA

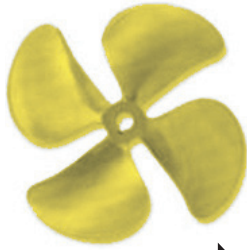

NEW ENGLAND PROPELLER, INC.

Distributor of Michigan Propellers

Inboard • Outboard

Next Generation 3D Computerized Propeller Analyzer
Computerized Dynamic Balancing



Marine Fuel Tanks

Custom Fabricated & Tested to U.S.C.G Specifications
By Capeway Welding

- Marine Propeller Sales & Repairs - ***4000 Props in Stock***
 - Sierra Engine Parts for All Outboards & IOs
 - CDI Electronics • Camp & Godfrey Zincs
 - NGK Spark Plugs
 - Duramax Cutless Bearings • Spurs Line Cutters
 - PSS Dripless Shaft Seals
 - Buck Algonquin - Struts, Rudders & Stuffing Boxes
 - S/S Shafting • Drive Savers • Globe Impellers



9 Apollo Eleven Rd., Plymouth, MA 02360
Tel: 508-747-6666 800-635-9504 - neprop.com



MEMBER/ATTENDEE INFO

Annual Weekend & Industry Trade Show 2023

March 23-26, 2023

Dear MLA member and Annual Weekend attendee,

In an effort to reduce our carbon footprint on the earth we are now going paperless and all the information and registration forms will be sent out in our weekly emails and are available on the MLAs website Annual weekend page www.lobstermen.com. If you would like the registration forms mailed to you directly, please call the MLA office and speak with Tracey at 781.545.6984 Ext.2.

The 2023 MLA Annual Weekend and Trade Show is scheduled for March 23rd-26th, 2023 at the Resort and Conference Center at Hyannis, 35 Scudder Ave, Hyannis, MA 02601.

<http://www.capecodresortandconferencecenter.com>

If you have not attended the Annual Weekend and Trade show in many years, well then this is the year you won't want to miss out on all the fun and camaraderie. There will be lots of giveaways, raffles, Casino night, great entertainment and laughs with friends you may not have seen in years!

All rooms and booths are on a first come first serve basis. If you would like a specific room or booth location DO NOT delay in getting you reservations in early.

The last trade show was a great success thanks to the many MLA members, vendors and show attendees who are dedicated to the fishing industry. The Annual Weekend Committee continues to work hard to bring you new vendors to keep you up to date with all the newest gadgets and equipment in the industry.

If you are interested in helping at the show, please call the office and we will be more than happy to have your help. Let's make this 2023 Annual Weekend one to remember!

See you in March,
Annual Weekend Committee

Resort and Conference Center
35 Scudder Avenue
Hyannis, MA 02601
Main Phone: 508-775-7775

Massachusetts Lobstermen's Association
Annual Weekend and Trade Show 2023
HOTEL RESERVATION FORM
Thursday, March 23, 2023 - Sunday, March 26, 2023

NAME(S): _____
ARRIVAL DATE: _____ DEPARTURE DATE: _____
ADDRESS: _____
CITY: _____
DAY TELEPHONE: _____
E-MAIL ADDRESS (REQUIRED): _____
CREDIT CARD TYPE: _____
EXPIRATION DATE: _____

Check	Package
<input type="checkbox"/>	1 Night Package
<input type="checkbox"/>	2 Night Package
<input type="checkbox"/>	3 Night Package
<input type="checkbox"/>	4 Night Package
<input type="checkbox"/>	5 Night Package
<input type="checkbox"/>	6 Night Package
<input type="checkbox"/>	7 Night Package
<input type="checkbox"/>	8 Night Package
<input type="checkbox"/>	9 Night Package
<input type="checkbox"/>	10 Night Package
<input type="checkbox"/>	11 Night Package
<input type="checkbox"/>	12 Night Package
<input type="checkbox"/>	13 Night Package
<input type="checkbox"/>	14 Night Package
<input type="checkbox"/>	15 Night Package
<input type="checkbox"/>	16 Night Package
<input type="checkbox"/>	17 Night Package
<input type="checkbox"/>	18 Night Package
<input type="checkbox"/>	19 Night Package
<input type="checkbox"/>	20 Night Package
<input type="checkbox"/>	21 Night Package
<input type="checkbox"/>	22 Night Package
<input type="checkbox"/>	23 Night Package
<input type="checkbox"/>	24 Night Package
<input type="checkbox"/>	25 Night Package
<input type="checkbox"/>	26 Night Package
<input type="checkbox"/>	27 Night Package
<input type="checkbox"/>	28 Night Package
<input type="checkbox"/>	29 Night Package
<input type="checkbox"/>	30 Night Package
<input type="checkbox"/>	31 Night Package

Package prices are inclusive of _____

Check: _____
Hotel Only. No meals included. Room and tax included in fee.

**JOIN THE EVENT!
GO TO
WWW.LOBSTERMEN.COM
TO DOWNLOAD THE
REGISTRATION FORMS
TODAY!**



SPONSOR INFORMATION

Annual Weekend & Industry Trade Show 2023

March 23-26, 2023

The Massachusetts Lobstermen's Association will be holding its Annual Weekend & Industry Trade Show 2023 at the Resort and Conference Center at Hyannis, Hyannis, MA on March 23rd (set up day) through March 26th, 2023.

The show hours are Friday & Saturday 9:00 AM-5:00 PM & Sunday 8:00 AM -10:00 AM. The aim of this event is to provide an opportunity for lobster fishermen, dealers and equipment suppliers to get together for communication, education and to have some fun too. The MLA provides educational grants to college bound children of our members and has given out over nine thousand dollars per year for the last many years.

The Annual Weekend Committee is asking if you would help us by being a sponsor for one of our show activities or raffles. These are some of the sponsorship opportunities; the Scholarship Fund Raffle, The Hospitality Suite, the Craft, the Entertainment, and the printing of the program.

All contributors will be recognized in the show program. Please note all donors will be listed in the show program as long as the donations are received prior to March 4th. All others will be noted in the following MLA newspaper.

The MLA currently has over 1,800 members which include lobster fishermen, lobster and seafood dealers and equipment suppliers and works all year for the collective good of the resource and the lobster industry.

Admission to the Trade Show Exhibit Halls and Seminars is FREE

We sincerely hope that you will consider helping us out and we thank you in advance for any support you can give.

— Annual Weekend Committee

The Massachusetts Lobstermen's Association

Annual Weekend & Industry Trade Show 2022

— SPONSORSHIP DONATION FORM —

Name: _____ Amount: \$ _____

What would you like to sponsor?

- | | |
|--|---|
| <input type="checkbox"/> Scholarship Fund Raffle | <input type="checkbox"/> Craft |
| <input type="checkbox"/> Hospitality Suite | <input type="checkbox"/> Entertainment |
| <input type="checkbox"/> Printing of Program | <input type="checkbox"/> Let Committee decide |

THANK YOU FOR YOUR CONTINUED SUPPORT OF THE MLA ANNUAL WEEKEND & TRADE SHOW

Please return this slip with your donation to: **Massachusetts Lobstermen's Association, 8 Otis Place, Scituate, MA 02066**



EXHIBITOR INFORMATION

Annual Weekend & Industry Trade Show 2023

March 23-26, 2023

Dear Exhibitor;

We are excited to offer you the opportunity to celebrate with us and to present and/or sell your products and services to a group of more than 1,800 Commercial Fishermen during our Annual Weekend & Trade Show starting on Friday, March 23RD-26TH, 2022. The 23rd is vendor set up day. The event will be held at the Resort and Conference Center at Hyannis, MA. <http://www.capecodresortandconferencecenter.com>

In an effort to reduce our carbon footprint, all the show information and registration forms will be sent out in our weekly emails and available on the MLA website; Annual Weekend page www.lobstermen.com. If you prefer the registration forms mailed to you directly, please call MLA office and speak with Tracey- 781.545.6984 Ext.2.

- The MLA recognizes that you may not have time to eat lunch on set up day; we will provide lunch in the exhibit hall on Thursday, March 23rd, 12:00pm-1:00pm
- In addition to the Friday and Saturday 9:00am-5:00pm hours, the exhibit hall will be open on Sunday morning an hour earlier at 8:00am and remain open until 10:00am so that you will have two hours of uninterrupted time.
- The MLA gives cash prizes to those exhibitors who remain set up until 10:00am on Sunday. **YOU MUST BE AT YOUR BOOTH BY 8:00am TO GET YOUR TICKET!**
- A single Booth space includes one 6' table with a tablecloth and 2 chairs. We will work with you if you need a little more room.

Once we receive your payment, we will mail you a confirmation letter for your booth and have it waiting for you beginning at 10:00am on Thursday, March 23rd for set-up. If the Thursday set-up day is a difficulty for you, we can make special arrangements to admit you early on Friday morning March 24th. However, please be advised that the Exhibit Hall opens at 9:00am and all exhibits must be fully set up by 9:00am. (Show hours are Friday & Saturday 9:00am-5:00 pm and Sunday 8:00am -10:00am)

All goods must be removed by 1:00pm on Sunday afternoon, March 26th. If you are unable to remove your entire exhibit by this time, you may make special arrangements for Monday morning as long as arrangements are made in advance.

If you have questions or need further information, contact MLA office and speak with Tracey 781.545.6984 Ext 2. We look forward to seeing you at the show.

Thank you,
MLA Annual Weekend Committee



EXHIBITOR RESERVATION

Annual Weekend & Industry Trade Show 2023

March 23-26, 2023

Massachusetts Lobstermen's Association
 8 Otis Place, Scituate, MA 02066-1323
 Tel (781) 545-6984 Fax (781) 545-7837
 Tracey.Abboud@lobstermen.com

Annual Weekend & Trade Show 2023
 March 23rd - March 26th 2022 (set up on March 23rd)
 Resort and Conference Center of Hyannis
 35 Scudder Ave, Hyannis, MA 02601

Exhibitor Booth Reservation—2023

Booth's include a 6' covered table & 2 chairs

- () 1 Booth \$650 _____
- () 2 Booths \$950 _____
- () 3 Booths \$1250 _____
- () Electricity \$75 _____
- () Lift for Engine \$150 _____

Total Enclosed \$ _____

Set-up begins at 9:00 AM on Thursday (March 23rd) and must be completely removed by 1:00 PM on Sunday unless other arrangements have been made in advance.

ALL BOOTHS MUST REMAIN INTACT AND YOU MUST BE AT YOUR BOOTH BY 8:00 AM Sunday to qualify for the vendor raffle. CASH PRIZES THE BOOTH MAY NOT BE DISMANTLED UNTIL 10:00 AM SUN. (March 26th)

Company Name: _____

Address: _____

City, State, Zip Code: _____

Daytime Tel: (_____) _____ Fax: (_____) _____

Person in Charge of Booth: _____ E-mail: _____

Primary Product or Service: _____

(If you are having an engine delivered PLEASE call and schedule a delivery time with Tracey Abboud 781-545-6984 xt. 2 —Thank you)

Special Requests or Needs: _____

(If you already register for the 2020 Annual Weekend you are all set)

Payment Info: () MasterCard () Visa () Check (Payable to MLA)

Name on card: _____

Card # _____

3 numbers on back of card: _____ Card Exp Date _____
 (You may call this number in)

Signature: _____

WE DELIVER FRESH LOBSTER BAIT

INCLUDING:

HERRING

POGIES

MACKEREL

RED FISH

SKINS

BLUEFISH

CHUM

SALMON
HEADS



FRESH, SALTED, AND QUICK FROZEN BAIT

Barrel Head Bait

WE SELL SALT!

For More Information:

To Place An Order:

Mark Flight
mark@barrelheadbait.com

The Bait Line:
857-200-2129
Or Fax:
617-561-8471



EXTRA MEAL TICKETS

Annual Weekend & Industry Trade Show 2023

March 23-26, 2023

MLA Annual Weekend & Lobster Trade Show 2023
 RESORT AND CONFERENCE CENTER AT HYANNIS, MA
Order Form for Extra Meal Tickets

Day/Time	Description	Price Per Person	Number Requested	Total Price
3/24/23 Friday Evening Buffet 6:30 pm – 7:45 pm Comedy Show 7:45pm to 9:00pm	<u>Buffet Dinner</u> Roasted Tomato Soup Mixed Garden Greens 2 choice of dressings Roasted Chicken with Cornbread and Dried Fruit Stuffing Braised Beef Short Ribs Chefs Selection of Starch and Seasonal Vegetables White Chocolate Bread Pudding Coffee and Tea	\$50.00		
3/25/2023 Saturday Evening Dinner 6:30 pm Dinner Award Ceremony 8:00pm Casino Night 9:00pm – 11:00pm Please choose Entrée	<u>Banquet Dinner</u> New England Clam Chowder Caesar Salad Choice of Cod or Prime Rib of Beef Warm Rolls Chef's choice of Starch, Vegetable, Dessert, Coffee and Tea (Please Choose Entrée) Local Cod- Prime Rib of Beef-	\$65.00		
		Total Amount Enclosed: \$		

Name: _____ Tel : _____
 Address: _____

Visa Master Card Check payable to MLA

Name on Card _____
 Card Number: _____ Exp Date: _____
 Last 3 numbers on back of card: You may call this number in: _____
 Signature: _____ Today's Date: _____

Mail this form to:
 Massachusetts Lobstermen's Association
 8 Otis Place, Scituate, MA 02066
 Tel. (781) 545-6984



HOTEL RESERVATION FORM

Annual Weekend & Industry Trade Show 2023

March 23-26, 2023



**Resort And
Conference
Center
At Hyannis**

35 Scudder Avenue
Hyannis, MA 02601
Main Phone: 508-775-7775

Massachusetts Lobstermen's Association Annual Weekend and Trade Show 2023

HOTEL RESERVATION FORM

Thursday, March 23, 2023 - Sunday, March 26, 2023

NAME(S) _____

ARRIVAL DATE: _____ DEPARTURE DATE: _____

ADDRESS: _____

CITY: _____ STATE: _____ ZIP CODE: _____

DAY TELEPHONE: _____ FAX: _____

E-MAIL ADDRESS (REQUIRED): _____

CREDIT CARD TYPE: _____ CREDIT CARD NUMBER: _____

EXPIRATION DATE: _____ SIGNATURE: _____

Hotel & Meal Package Options						
Check Choice	Package Type	Nights	Cost Per Package	Friday Evening Buffet	Saturday Evening Banquet Select One per Adult	
					Prime Rib	Local Cod
	1 Night Package, 1 Adult	Friday Only	\$154.89	Included	Not Included	Not Included
	1 Night Package, 2 Adults	Friday Only	\$191.89	Included	Not Included	Not Included
	1 Night Package, 3 Adults	Friday Only	\$240.34	Included	Not Included	Not Included
	1 Night Package, 1 Adult	Saturday Only	\$189.89	Not Included		
	1 Night Package, 2 Adults	Saturday Only	\$261.89	Not Included		
	1 Night Package, 3 Adults	Saturday Only	\$345.34	Not Included		
	2 Night Package, 1 Adult	Fri & Sat	\$344.82	Included		
	2 Night Package, 2 Adults	Fri & Sat	\$453.86	Included		
	2 Night Package, 3 Adults	Fri & Sat	\$585.80	Included		
	3 Night Package, 1 Adult	Thurs, Fri & Sat	\$462.63	Included		
	3 Night Package, 2 Adults	Thurs, Fri & Sat	\$571.59	Included		
	3 Night Package, 3 Adults	Thurs, Fri & Sat	\$714.90	Included		

Package prices are inclusive of all taxes, gratuities and service fees.

Additional Hotel Options			
Check One	Additional Nights	Indicate Dates/Number of Adults	Cost
	Hotel Only. No meals included. Rate is per night for 1 or 2 adults. Rate is inclusive of tax.		\$130.47 Per Night



HOTEL RESERVATION FORM

Annual Weekend & Industry Trade Show 2023

March 23-26, 2023

RESERVATION POLICIES

Cutoff Date: All reservations for guestrooms must be made by Monday, March 13, 2023. After this date, we cannot guarantee the availability of guestrooms or the group rate.

Meal Tickets and Choices: All meal choices for the Saturday night banquet must be made prior to March 13, 2023. If meal selection is not made by this date, we cannot guarantee your preferred meal choice. *Meal selections and number of guests in the package may not be adjusted within 10 days of arrival.*

Deposit: We require a deposit of \$100.00 at the time the reservation is made. If the deposit is by credit card, we will charge the deposit in advance when the Reservation Form is received.

Cancellation Policy: If an individual reservation is cancelled (7) seven days or more prior to arrival the deposit is refunded less a \$15.00 service charge. If an individual reservation is cancelled (6) six days or less or the guest does not arrive on the specified dates, the reservation is cancelled for all nights and the deposit will be forfeited. The remaining nights on the reservation will also be cancelled and are not automatically reinstated.

Confirmation: A confirmation email will be sent to you directly from the Resort and Conference Center at Hyannis.

CHECK-IN TIME AFTER 3:00 PM - CHECK-OUT TIME BY 11:00 AM

Please Fax, Email or Mail completed form to our Reservations Department (1 form per room)

Updated Fax Number: 508-778-6910

Email: stay@capecodresortandconference.com

Mail: Resort & Conference Center at Hyannis, 35 Scudder Avenue, Hyannis, MA 02601.

Please make checks payable to the Resort and Conference Center at Hyannis.

This form must be received prior to March 13, 2023. Phone or online reservations will not be accepted.

Any changes to your reservation must be made by submitting a revised form.
Please note change and mark form as "REVISED" to avoid duplicate reservations.



Radioactive water release from Oyster Creek nuclear plant concerns environmentalists

By **Amanda Oglesby**, Asbury Park Press
LACEY - Water with “low-level” amounts of radiation recently was discharged from the defunct Oyster Creek nuclear power plant, according to the Nuclear Regulatory Commission, which oversees radiation-related activity at the plant.

Holtec International released about 24,000 gallons of water from the facility as part of its ongoing decommissioning activities, NRC spokesman Neil Sheehan said in an email. The water was slowly released starting Sept. 7 and took two days to complete, he said.

The water contains low levels of radiation and comes from the plant’s nuclear fuel rod cooling pool, the reactor cavity and an equipment pit, Sheehan said.

The water releases are regulated by both the NRC and the federal Environmental Protection Agency in order to protect the public, he said.

Staff at the power plant have performed such releases of low-level radioactive water throughout the facility’s operating life, said Sheehan and Holtec spokesman Joseph Delmar. The action is part of routine operations, not just at Oyster Creek, but at nuclear plants across the nation, Delmar said in an email to the Asbury Park Press. Water was integral to the functioning and safety at Oyster Creek throughout the plant’s nearly 50 years of generating electricity. Steam heated by nuclear energy was used to drive the plant’s turbine, converting that energy into electricity. Water

also was used to cool spent fuel rods inside a large pool.

Oyster Creek produced its last electricity in 2018. The facility’s age coupled with competition from inexpensive natural gas made the nuclear plant too costly to operate. In 2019, its then owner Exelon sold the plant and its nearly \$1 billion decommissioning trust fund to Holtec International.

In May, Holtec announced that the last of the spent fuel rods from decades of power generation were removed from the cooling pool and transferred to dry cask storage. Now the company is draining water from the pool, the reactor and an equipment storage pit, Sheehan said.

“Our process for water use falls in step with our commitment to environmental stewardship,” Delmar said.

The radioactive water is collected in 30,000-gallon batches and run through a series of filters and demineralizers, he said. Afterward, the water is thoroughly tested, and then reused inside the plant or diluted and discharged into canals, he said.

“Our sample results show that the canals around Oyster Creek have been, and remain, safe to swim, fish and boat in,” he said.

Since decommissioning began three years ago, the plant has discharged, on average, about 64,000 gallons of treated, diluted water a month into the canals, Delmar said.

Holtec found discharging the

water to be the best way to handle the material compared to the company’s alternatives, he said.

“Evaporation releases higher levels of radioactive materials due to the concentration and lack of dilution when the water becomes a gas,” Delmar said. “Shipping to another site for disposal creates a larger carbon footprint with hundreds of truck trips.”

Local environmentalists say they are not reassured because plant officials did not share information about the release prior to taking action.

Janet Tauro, New Jersey chair of the environmental organization Clean Water Action, said the water release signaled a lack of transparency on the part of Holtec.

“The public was not alerted to when the releases would occur,” said Tauro, who learned about the release while researching Holtec’s decommissioning work at the defunct Pilgrim Power Station in Massachusetts. “They (Ocean County residents) weren’t given the opportunity to ask questions.”

Britta Forsberg, executive director of the environmental group Save Barnegat Bay, said she was watching volunteers build oyster reefs near the mouth of the Forked River just days after the plant’s radioactive water release. Oyster reefs help prevent shoreline erosion, filter the bay’s water and provide crucial habitat for marine animals, but Forsberg said the effects of low-level radiation on the growing oysters remain unknown.

“If I was putting myself in the water, doing all this work (building oyster reefs), I might want to ask some questions and know what’s in there (the bay water).”

Edwin Lyman, director of the nuclear power safety program at the Union of Concerned Scientists, said the radioactive water release raises questions about regulatory oversight of nuclear facilities.

Too little research is done on the impacts of the discharges, to know whether radiation from the releases accumulates in certain animals or concentrates into particular areas of the ecosystem over time, Lyman said.

“It’s a difference between what’s allowable and what’s right,” he said.

Delmar, of Holtec, said the company remained committed to environmental stewardship and was operating within the law and Nuclear Regulatory Commission’s limits on radiation releases.

But Lyman questioned the science behind those limits.

He said, “The larger question is are the limits that the nuclear industry is allowed to adhere to, with regard to routine radioactive discharges, are those the right numbers?”

Amanda Oglesby is an Ocean County native who covers Brick, Barnegat and Lacey townships as well as the environment. She has worked for the Press for more than a decade. Reach her at @Oglesby-APP, aoglesby@gannettnj.com or 732-557-5701.

Store Special

Yellow Plastic Bait Bags:
18" long, bundle of 20, \$12 each (regular \$15)
While supplies last!



111 Myrtle Street
New Bedford, MA 02740
508.997.4787



www.ketchamsupply.com
info@ketchamsupply.com
f @ketchamtraps



Legal Defense Fund Updates

The Massachusetts Lobstermen's Association (MLA) Legal Defense Fund (LDF) needs your support now more than ever. This dedicated fund is for the purpose of defending the Massachusetts commercial lobster fishermen from legal and fisheries management actions that could seriously impact our commercial lobstermen's ability to conduct their businesses and earn a living.

Currently, the MLA is actively engaged in three separate lawsuits that could have negative impacts on the commercial lobster industry and is working with multiple lawyers in Washington D.C. and here in the Commonwealth to fight for you and your industry.

UPDATE SEPTEMBER 21, 2022 — (Washington D.C.) Case 1:18-cv-00112-JEB - CENTER FOR BIOLOGICAL DIVERSITY et al v. ROSS et al, the Plaintiffs requested that the Court issue an order:

1. Declaring that NMFS violated the ESA and APA for issuing an ITS in the 2021 BiOp for zero lethal right whale take in the federal fishery without first authorizing incidental take under the MMPA, 16 U.S.C. § 1371(a)(5)(E);

2. Declaring that NMFS violated the ESA and APA by anticipating but not authorizing lethal take in the federal lobster fishery in the 2021 BiOp ITS;

3. Declaring that NMFS violated the MMPA and APA in issuing a final rule amending the Plan that failed to contain the measures the agency expected would reduce right whale M/SI in the U.S. lobster fishery in both state and federal waters to below PBR within six months of implementation;

4. Vacating and remanding the 2021 BiOp with respect to the right whale and the federal lobster fishery with vacatur stayed for six months and ordering NMFS to produce a new biological opinion that includes fully complies with the requirements of the MMPA and ESA in authorizing any anticipated lethal take of right whales in the federal lobster fishery; and

5. Remanding without vacating the Final Rule and ordering NMFS to issue a new rule within six months of the order that contains the measures NMFS expects will reduce right whale M/SI in the U.S. lobster fishery to below PBR within six months of the rule's implementation.

While we obviously do not agree with their analysis, science, and most of what they seek (including their apparent opposition to weak rope and intent to push the industry into ropeless fishing), we are encouraged by the fact that we (and others) were able to persuade the NGO's to not seek a restraining order concerning our lobstermen's ability to fish even if the Court vacates and remands the 2021 BiOp and orders NMFS to produce a new biological opinion, that, in the Plaintiffs or in the Court's view, fully complies with the requirements of the MMPA and ESA. As it now stands, the CBD Plaintiffs request that, if the Court vacates and re-

mands the 2021 BiOp and orders NMFS to produce a new BiOp and Final Rule, our fishermen be able to continue to fish as-is for at least 6 months post Court decision and until NMFS fashions a new BiOp and new Final Rule.

NMFS's remedy brief (limited to 30 pages) was filed on September 19, 2022. In its briefing, NMFS proposed the Court set a date of December 9, 2024, for it to issue a TRP amendment remedying the deficiencies in its. As part of this proposal, NMFS also requested that the 2021 BiOp be remanded without vacatur through to December 9, 2024.

NMFS noted the extreme difficulty it would have in meeting Plaintiff's proposed six-month deadline and explained that it would need to take in additional research and data, including on death dispersions from Canada and the US, to make a proper ITS. This is encouraging to see, as the Court recently determined that NFMS's method for assigning deaths between Canada and the US was reasonable (although we strongly disagree).

However, a large part of NMFS's proposed remedy was focused on implementing and advocating a migration away from VBR which is of course untenable for the vast majority of our members.

The remainder of the briefing schedule is as follows:

- 1) Intervenor-Defendants' (including us and other Maine interests) remedy briefs (limited to 30 pages) are due by October 7, 2022; and 2) Plaintiffs' consolidated reply has been filed on 8/12/22 and is posted on the MLAs website home page under the Right Whale Litigation and Management updates.

UPDATE SEPTEMBER 21, 2022 — (D.C.) Maine Lobstermen's Association, et al. v. NFMS

ORDER GRANTING SUMMARY JUDGMENT - Judge Boasberg has issued his summary judgment order in MLA v. NMFS ruling against the Maine Lobstermen's Association (and us) on every single ground we raised challenging the 2021 BiOp. This is a very disappointing order that we appealed to the D.C. Circuit. In his Order, Judge Boasberg did the following:

1. The Court then found that several grounds raised by the Maine Lobstermen's Association should have been brought in the complaint and, because they were not, the Court would not consider them. This includes the following arguments: (Opinion at 11)

- a. Regularly Flexibility Act
- b. MMPA's purposes
- c. Composition of the take-reduction team

2. Turning to the challenges to the BiOp itself, the Court first ruled as a general matter that NFMS applied the "best scientific and commercial data available", meaning that challenges to NFMS' scientific determinations were not going to succeed. It made this ruling on the basis that data was

limited and the agency made valid determinations within the range of scientific judgment

- a. As part of this conclusion, the Court dismissed the argument that the NFMS' Consultation Handbook required different scientific analysis by determining that it only requires using the best scientific, which the Court believed NFMS used

3. We then arrive at the more specific claims that was raised against NFMS

- a. US/Canada Allocation: The Court determined that the data about where deaths were occurring was uncertain so it was fair for NFMS to use a 50/50 split, especially when the Center for Independent Experts determined the approach was "reasonable".

- b. Unknown Origin Entanglement: The Court determined that the unknown origin death data was limited and that it wasn't unreasonable to attribute it to gillnet fishing and VBR especially since deaths seem to happen in VBR areas.

- c. Cryptic Mortality: The Court determined that NFMS used a "rigorous peer reviewed method" developed by whale researchers to determine where deaths occurred and that the fact that whales migrate doesn't affect this.

- i. The court also determined that natural mortality challenge was adequately explained by NFMS as mostly occurring to whale calves so adult deaths are likely caused by humans.

- d. The Court also wholly rejected any reliance on harm mitigation methods deployed by MLA because NFMS did not have access to data on the mitigation measures but incorporated the effects into its modeling as best it could

- e. Finally, the Court determined that NFMS could use the "Linden model" and the Decision Support Tool because they are peer-reviewed and thus constitute best date

4. The Court rejected the argument that NFMS attributed too many deaths to the lobster industry, explaining that NFMS had to fall below the PBR because it was just one part of many government agencies impacting whale populations and thus could overestimate the harm

5. Having found that the BiOp survives the challenges against it, the Court then said that the Final Rule also survived because the only challenge to it was that the BiOp was invalid

At the end of its Order, the Court did note that it "fully expects that NMFS will continue diligently incorporating the latest information, considering the concerns of all stakeholders, and adapting to changing circumstances in making its future decisions". (Order at 33).

We disagree with the Court on each of the grounds it found and will vigorously challenge them on appeal.

LDF Updates

FROM PAGE 35

UPDATE SEPTEMBER 21, 2022 — (Boston) M.S vs. D. McKiernan et. al.

ORDER TO SHOW CAUSE August 16, 2022
TALWANI, D.J. Plaintiff MS filed a complaint in this case on March 9, 2022. See Verified Complaint [Doc. No. 1]. Summonses were issued on March 14, 2022. [Doc. No. 9]. Fed. R. Civ. P. 4(m) provides that “[i]f a defendant is not served within 90 days after the complaint is filed, the court—on motion or on its own after notice to the plaintiff—must dismiss the action without prejudice against that defendant or order that service be made within a specified time.”); Local Rule 4.1(b) (“If on the 14th day following the expiration of the 90-day period good cause has not been shown [for the failure to make timely service] . . . the clerk shall forthwith automatically enter an order of dismissal”).

Plaintiff did not serve Defendants by June 12, 2022, that is, within 90 days as required by the Rule. Case 1:22-cv-10364-IT Document 46 Filed 08/16/22 Page 1 of 2 2 Between June 14, 2022, and June 28, 2022, Plaintiff attempted to bring several motions to extend the deadline for service. The court struck these motions for failing to comply with the Local Rules and this court’s orders. Orders Striking Motion [Doc. Nos. 22, 26, 30]. Plaintiff has made no further request to extend the deadline for service, and to date, the summonses have not been returned with proof of execution.

Accordingly, the case is subject to dismissal. If Plaintiff believes dismissal for failure to serve the Defendants is unwarranted, he shall file by no later than August 23, 2022, a response to this order setting forth good cause why the court should not dismiss the case. **IT IS SO ORDERED.** August 16, 2022 /s/ Indira Talwani United States District Judge.

On August 31, 2022, Judge Talwani dismissed MS’s complaint and also denied the motion for pre-filing injunction brought by the MLA against him to stop MS from using the legal system to abuse MLA and our members. In denying the pre-filing injunction, Judge Talwani stated “[w]hile relief appears to be warranted, Sawyer has not filed any cross-complaint for abuse of process (or any other independent legal claim),” which we could not have because we had not been served. In other words, the Judge warned MS that she will grant the vexatious litigant motion if he files additional lawsuits against the MLA and its members. It remains to be seen if MS will heed Judge Talwani’s clear warning. However, we find this Order encouraging, as if MS sues the MLA or its members again, we will immediately bring the vexatious litigant motion and a claim for abuse of process, which in light of Judge Talwani’s Order, we believe will be successful. The commercial lobstermen’s businesses are at stake as well as the thousands of jobs and shore side businesses that depend upon the continued success of the commercial lobster industry. The commercial lobstermen in Massachusetts are NOT to the

problem and have done everything asked of them by National Marine Fisheries Service and have been working under the strictest conservation rules for the right whales anywhere in the world since 2014. Yet here we are, still fighting these lawsuits to keep the Massachusetts commercial lobstermen fishing.

The Massachusetts Lobstermen’s Association has been actively involved in these lawsuits since 2018 and we need your generous support today to continue our fight to keep the commercial lobstermen fishing. As we all know, any legal action costs lots of money and over the last 5 years the Massachusetts Lobstermen’s Association Legal Defense Fund has spent over \$300,000 fighting these legal battles. These are real threats to the historic and iconic commercial lobster industry and we are doing everything to keep the Massachusetts commercial lobstermen fishing.

WHERE TO MAKE DONATIONS

Any contribution you can afford to make to the Legal Defense Fund is greatly appreciated.

Donate by mail:

MLA LDF,
8 Otis Place
Scituate, MA 02066

Donate online:

www.lobstermen.com

– In the Members section
select Dues/Donate.

THANK YOU FOR YOUR CONTINUED SUPPORT!

Are you thinking of buying or selling?

Boats | State and Federal Permits | Complete Businesses

ATHEARN MARINE AGENCY, INC.



SERVING FISHERMEN SINCE 1946

Tel: (508) 999-4505

Email: sales@athearnmarine.com

www.athearnmarine.com

10 Union Wharf, Fairhaven, MA 02719





DONATE TODAY!

to the Massachusetts Lobstermen's Association

LEGAL DEFENSE FUND

OCTOBER 2022 SUPPORTERS

- | | | | |
|-------------------|---------------------|--------------------|---------------------|
| John Barrett | Glen Fernandes | Peter Lagerstrom | Paul Quintal |
| Michael Bartlett | Timothy Field | George Landers | Christopher Rainone |
| Kevin Beaton | Michael Frontiero | Stephen Larsen | Mike Rego |
| David Breen | Charles Galinauskas | JT Lobster | Mark Ring |
| Alex Brown | Joseph Gallagher | Eric Lorentzen | Leo Rose |
| Mark Byard | Stephen Gilbert | Donald Lowe | Andrew Santapaola |
| Richard Cadigan | Andrew Glynn | Richard Luedtke | Patrick Santos |
| William Chaprales | Craig Hillier | William Maculewicz | Therese Sauvageau |
| Matt Conlon | John Hobby | Peter Mahoney | Edward Eric Smith |
| Peter Crowell | Patrick Hogan | William Mahoney | John Snow |
| A. Mark Davis | Dan Holmes | David Mallowes | Michael Sosnowski |
| Edward Deputat | Kurt Holmes | William Martin | Jeff Souza |
| Edward Desrosier | Mark Irvine | Johnathon Mason | Domenic Spinale |
| Erik DeWolfe | Ralph Jacobs | James Mataronas | Michael Sprague |
| Todd Dexter | Todd Jesse | John W. McCarthy | John Symonds |
| Joseph DiGenio | David Jewell | Bob Nihtila Sr. | Eric Todd |
| Fanel Dobre | James Kandrick | William Oliver | William VanDuzer |
| Daniel Donovan | Dean Karoblis | Jason Polisson | Stephan Willard |
| Scott Elliot | Mike Kartasiewicz | Anthony Ponte | |
| Bryan Ewing | Steve Keene | Stephen Powers | |



Donate to the MLA Legal Defense Fund to
“Band the Bite” TODAY!

Help us fill the lobster crate and help relieve the **“PINCH”** of defending commercial lobstermen!

Let's fill the lobster crate TODAY!

Every \$25 dollars donated puts another lobster in the lobster crate!!

There are several ways to make a donation

MLA website: www.lobstermen.com Legal Defense Fund Donation

Paypal: Legal Defense Fund Donation

Mail or drop off a check:

MLA, 8 Otis Place, Scituate, MA 02066

Call the MLA : 781-545-6984 xt2

Use your camera on your phone to Scan the QR Code

THANK YOU for YOUR CONTINUED SUPPORT!



MLA Classifieds

Classified ads are a free benefit to MLA Members and Non-members are a flat \$25.00. Ads run for 5 months & will be automatically deleted unless you call the MLA office to renew. 781-545-6984 or email ads to: tracey.abboud@lobstermen.com
*All ads are subject to review prior to placement

AD #1 (10/22) **FOR SALE** – Area 1 Coastal Lobster Permit Call 508-824-0177

AD#2 (9/22) **FOR SALE** – Trap Trailer 6x12 can hold approx. 50-3 footers. Good shape. \$1,200.00 Call Ben@ 978-578-8882

AD#3 (6/22) **FOR SALE** – Hydraulic Components, parts and service. Pumps, Motors, Valves and Accessories. Hydraulic Hoses made while you wait. Great Prices–Same day service (in many cases)-Wide selection of in-stock items. Rebuilt items occasionally available. ROSE MARINE, Gloucester, MA 877-283-3334

AD#4 (10/22) **FOR SALE** - 800 lobster pots 36 x 22 1/2 x 15 5 years old -new -all ground lines included. 10 pot trawls- all spliced. 3-brick in every pot-haul from starboard & kitchen. 10-12 gauge wire. Call Dick @ 774-218-4701 for more details.

AD#5 (9/22) **FOR SALE** – 24 Crosley net lift \$2,000.00-15 ft. of 7 1/2 inch mooring chain \$50.00. 24 gillnet hauler springs \$4.00 each 20lb. 3/4 stainless steel hog rings B.R.O. 20lb. 1/2 hog rings. 2 – 55 gallon barrels of 7/16th ground line B.R.O. 10-white pingers \$25.00 each Used Gillnets foam and standup B.R.O. Text Only 617-694-4802

AD#6 (9/22) **FOR SALE** – Marineland 55 gal Live Lobster Tank \$690.00 Call John @617-750-3263

AD#7 (8/22) **FOR SALE** – Cold water dive suit w/all accessories-used once-still in boxes. \$2,000.00 Call Robert @617-240-5196

AD#8 (9/22) **FOR SALE** – 38 ft Novi fiberglass over wood- John Deere 6068. 225hp 5,670 hours on Engine-Steams @8.5/9 knots 14 hauler Simrad Autopilot Inside/Outside steering stations- 150 gal fuel tank- Lobster tank holds 600lbs. Furuno GP-39 S inside- Furuno GP- 32 GPS outside- Furuno Radar, Furuno FCV-292 color video sounder-2VHF. Inside/Outside 2 computer monitors, one face inside- other faces outside

steering station. Very quiet engine. Asking \$15,000.00 Call 978-290-9929

AD#9 (8/22) **FOR SALE** – MA conch pot, scup pot, striped bass, sea bass, tautog etc. Traps. 35 nov 9knt boat 1 1/2 gal/hr, trap ramp, auto pilot bunks etc. \$85,000 Call 508 939 1231

AD#10 (6/22) **FOR SALE** - 1966 Cedar over Oak 34 wooden lobster boat. NE Ford Leaman 135 HP engine, re-built tranny, Stainless shaft, 4 blade prop. Built by Ano Day -Stonington Maine. Several upgrades throughout ownership of boat. In process of building a new boat- this boat was fished last season. \$7,500.00 or B.R.O. Call Dean @ 781-264-7501

AD#11 (5/22) **FOR SALE** - Warp– Used & some new, mostly knot free. 76 lbs. 5/16, 33 lbs. 3/18 \$99 takes all 508-269-1406 Plymouth

AD#12 (5/21) **FOR SALE** - 18 Wooden Lapstreak Skiff. In remarkable condition. Bottom was fiber-glassed before first used. All heavy duty oak ribs, stiffeners, ribs and floor cleats. Excellent boat for coastal/harbor fishing, or for lugging traps. Will send picture upon request. \$1,990.00 or BRO. Call 508 269-1406.

AD#13 (7/22) **FOR SALE** - Bronze dual ram steering Quadrant-Freeman Oval hatch-15x23 opening SS mast base. 2 2ft., outriggers-no base-Mike 978-745-6182 leave message

AD#14 (5/22) **FOR SALE** – 300 3 -Cement runners \$5.00 each Call 631-286-3335

AD#15 (9/22) **FOR SALE** – 12 Electra-dyne hauler & davit. \$1,800.00 Call John @ 617-750-3263

AD#16 (9/22) **FOR SALE** – Fiberglass mold/Swampscott style square bow 10 ft. flat bottom work skiff \$950.00 Call 978-578-8882

AD#17 (6/22) **HELP WANTED** – Lobster Boat located in Marshfield is looking for help for the 2022 fishing season. Experienced preferred but will train. No drama, no drugs & must have own transportation. Call 781-767-4130/508-510-7792

AD#18 (6/22) **FOR SALE** – 24' Privateer, 5.7L Crusader low hours, Honda hydraulic power pack with 10" hauler. S.S. Davit. Plotter, sounder, radar, VHF. New cockpit floor & deck with 2' stern extension. Rigged for pot hauling. Ready to fish. \$16,000. Area 2 coastal Mass lobster permit, 90 pot allocation \$25,000. Selling as a package, boat & permit \$35,000. Located in Oak Bluffs. Call-774-563-0393

AD#19 (8/22) **FOR SALE** – 200-LMA 2 EEZ/inshore dual zone trap tags \$27,000 call 508-542-5729

AD#20 (6/22) **FOR SALE** - 1,000 hooks new tub trawl-gear W/anchors, 180 buoy lines. B.R.O. Bryan @ 508-221-8568

AD#21 (6/22) **FOR SALE** - 1987 Daniels Head 39' 11" Fiberglass Gillnet boat. 207HP Mitsubishi D14.14 T Diesel engine (1992), Twin Disc 506 trans, complete electronics, 2 berth, 6'x5' aluminum gill net reel with stainless frame, 2 fish holds, 2 insulated deck boxes, rollers, 2 bus heaters, vessel in good condition – new fuel tank, new paint/fiberglass/ fish boxes (2022). \$79,500 or B.R.O. Fed Permit Monkfish B with around 80 nets and 16 dog nets with buoy st anchors \$45,000. Federal directed shark permit \$15,000. Call 609-294-1628 /text for pictures 609-713-5228

AD#22 (7/22) **WANTED** - Usable hauler valve for Hydro Slave 14 hauler. Gresen or compatible. Model- W42 or 25PV4 if possible. Call Augie 617-529-4640, leave message.

AD#23 (8/22) **FOR SALE** - 100 traps 36x21x15 \$10.00 each Life Raft \$500.00 Call 508-577-4868

AD#24 (8/22) **FOR SALE** - LMA-1 Federal lobster permit, 800 trap allocation, good history \$38,000.00 978-578-8882

AD#25 (9/22) **LINE FOR SALE** - 3-10 pot trawls of 7/16" Everson line-14 Fathom between traps-7/16" gangions-2 – 20 F x3/8 "buoy lines- In totes included -\$60.00 / trawl Call Joel @ 781 581 0324 or E-mail joel.w.marie@gmail.com

AD#26 (9/22) **FOR SALE** - 5" Superior hauling block-Aluminum construction with stainless sheave \$250.00 Call Joel @ 781 581 0324 or E-mail joel.w.marie@gmail.com

AD#27 (9/22) **FOR SALE** - Spare new stainless sheave for 5" Superior block-\$150.00 Call Joel @ 781-581-0324 or E-mail joel.w.marie@gmail.com

AD#28 (6/22) **FOR SALE** - two aluminum propellers 13.5x15 & 14x11 for Evinrude outboard were on 115 HP, great condition \$50. each Ipswich 978-356-4525

AD#29 (9/22) **FOR SALE**- Area 2 lobster permit 128 tag limit \$21,000.00 Call 774-775-2827

AD#30 (9/22) **FOR SALE**- 22ft. Siso Lobster boat 150HP Evinrude OB needs work has 12 hydraulics hauler runs off Honda hydraulics power pack needs work & comes with trailer. Asking \$13,000.00 or B.O. Call Robert @ 5:00p.m. 617-846-3714 or 617-650-3842

AD#31 (9/22) **FOR SALE**- #1 Bellhousing 2:1 gear reduction – re-built 51 14A – twin disc transmission- Down Angle-North Atlantic Power Products. 0- hours. 1000 hours or 6-months warranty. \$17,200.00 Call Peter @ 203-627-6070

CAT MARINE ENGINES

Tier 3 Commercial Line-up

C7.1



C7.1 Tier 3 Commercial Ratings:

280 HP @ 2300 Heavy Duty "B" **IN STOCK**
350 HP @ 2500 Maximum Continuous Duty "C" **IN STOCK**
400 HP @ 2600 Intermittent Duty "D" **IN STOCK**
425 HP @ 2700 Intermittent Duty "D" **IN STOCK**

C9.3



C9.3 Tier 3 Commercial Ratings:

375 HP @ 1800 Heavy Duty "B"
416 HP @ 2100 Maximum Continuous Duty "C"
476 HP @ 2300 Intermittent Duty "D"

C18



C18 Tier 3 Commercial Ratings:

470 HP @ 1800 Continuous Duty "A"
600 HP @ 1800 Continuous Duty "A"
670 HP @ 1800-2100 Heavy Duty "B"
715 HP @ 1800-2100 Maximum Continuous Duty "C"
803 HP @ 2100 Intermittent Duty "D"

* Tier 4 Exempt Light Commercial Ratings:

1,001 BHP @ 2300
1,136 BHP @ 2300

C32



C32 Tier 3 Commercial Ratings:

750 BHP @ 1600-1800
800 BHP @ 1600-1800

AUTHORIZED MARINE DEALERS

Billings Diesel & Marine Service

Stonington, ME

Dennis' Welding & Marine

Beals, ME

Front Street Shipyard

Belfast, ME

Lyman Morse at Wafarer Marine Corporation

Camden, ME

Journey's End

Rockland, ME

Fairhaven Shipyard & Marina, Inc.

Fairhaven, MA

Guy Crudele Repair

Gloucester, MA

Sacchetti Marine and Industrial LLC

Plymouth, MA

Windward Power Systems

Fairhaven, MA

DePaul Diesel Services, Inc.

Portsmouth, RI

Hinckley Yacht Service

Portsmouth, RI

Rhode Island Engine Company, Inc.

Narragansett, RI

*All T4 Exempt Light Commercial Ratings, require qualifications review and approval by CAT Factory.

*Contact Nick Fawle or Your Authorized Marine Dealer for Tier 4 exemption qualification details.

For Marine Engine Sales, contact Nick Fawle, our new Marine Market Manager.

Nick Fawle at 603-484-5248

Nick_Fawle@miltoncat.com

Milton



miltoncat.com

Massachusetts Lobstermen's Association
8 Otis Place
Scituate, MA 02066

PRSR STD
U.S. POSTAGE
PAID
Permit 137
New England Newspapers, Inc.



**Stock and Custom-Built Traps
Lobster and Specialty Traps
Aquaculture Supplies
Huge Inventory of Commercial
Fishing Supplies
Four Locations in Maine**



**BROOKSTRAPMILL.COM
(800) 426-4526**