



MASSACHUSETTS LOBSTERMEN'S ASSOCIATION

A LEADING Commercial Fishing Industry Association in New England



JOIN TODAY and
show your support

JUNE 2022 NEWSPAPER • WWW.LOBSTERMEN.COM

South Shore lawmakers want to pay lobstermen during months-long conservation closure

SCITUATE — State senators next week will debate a plan by South Shore lawmakers to pay lobstermen during a months-long annual fishing closure advocates say cuts income of some fishermen by as much as half each year.

State senators Patrick O'Connor and Bruce Tarr have filed a budget amendment that would allocate \$12 million to pay lobstermen \$1 per week per trap they are licensed for during time they are not allowed to fish. The state annually shuts down more than 9,000 square miles of water for at least three months in efforts to protect migrating right whales.

“Since the state is imposing these restrictions on the industry, we should be providing the industry with relief,” O'Connor, R-Weymouth, told *The Patriot Ledger*. “We've seen governments get creative with mitigating the problems that came with COVID shutdowns, and I see no difference here.”



The state senators were joined by state representatives Patrick Kearney and Joan Maschino, local fishermen and advocates at Scituate Harbor Friday, where O'Connor said they were asking for “just a small portion” of the \$640 million the industry produces each year to be returned to the lobstermen.

“These are real dollars being earned by real people supporting local economies, and

we need to show them we care about them,” said Beth Casoni, executive director of the Massachusetts Lobstermen's Association.

Since 2015, regulations have banned the use of lobstering equipment from Feb. 1 until at least April 30 off Cape Cod Bay and beyond, shutting down the local industry for the winter. The goal is to reduce the chances of right whales, which are common in Cape Cod Bay

during late winter and early spring, becoming entangled in the gear. For the last several years, the presence of right whales has pushed the closure to mid-May.

John Haviland, president of the South Shore Lobster Fishermen's Association, said Massachusetts fishermen have been at the forefront of right whale protection, and deserve relief in return.



SERIOUS ABOUT SAFETY

LRSE.COM | 401-816-5400

590 FISH RD, TIVERTON, RI 02878
 181 OLD COLONY AVE, UNIT A, BOSTON, MA 02127
 55 STATE ST, NARRAGANSETT, RI 02882



SALES • SERVICE • TRAINING • RENTAL • OUTFITTING • PICKUP + DELIVERY

Safety Equipment Servicing

Life Raft + Survival Equipment has been selling and servicing all major brands of Life Rafts, EPIRBs/PLBs, Life Jackets, Immersion Suits, and Man Overboard Equipment since 1983.

We offer pickup and delivery to over 20 locations throughout the Northeast.

CALL FOR GREAT PRICING.

North East Safety Training

NEST, a division of LRSE, offers hands-on Basic, Advanced, and Customized Safety Training Courses, Monthly Drill Conducting, First Aid/CPR/AED Courses and Vessel Inspections.

VISIT OUR WEBSITE TO LEARN MORE.

-  LIFE RAFTS
-  EPIRBs + PLBs
-  LIFE JACKETS
-  IMMERSION SUITS
-  MAN OVERBOARD
-  PICKUP + DELIVERY

COMMERCIAL LIFE RAFTS

Elliot, Zodiac, Crewsaver, Revere, Viking



FIBRELIGHT LADDERS

Man Overboard Recovery Cradle, Self Recovery Ladder



IMMERSION SUITS

Imperial



EPIRBs

ACR V4



FIRETKO®

Fire Suppression Tool



LIFE JACKETS

Mustang



MLA Sponsors

The following companies are proud supporting MLA members. We encourage our members to patronize them. If your company is not listed and you would like it to be, contact Tracey Abboud at 781-545-6984, ext. 2

ALIVE & KICKING LOBSTER

LOUIS MASTRANGELO
CAMBRIDGE, MA
617.876.0451

ALUMATECH MARINE

ANDY COSTA
PLYMOUTH, MA
508.746.7774

BAR HARBOR LOBSTER

JEFF HAZELL
ORLANDO, FL
407.851.4001

BOSTON LOBSTER

NEIL ZARELLA
617.464.1500
bostonlobstercompany.com

BOSTON SWORD & TUNA

STEPHEN SCOLA
BOSTON, MA
617.946.9850

BROOKS TRAP MILL

STEPHEN BROOKS
THOMASTON, ME
207.354.8763
stephen@brookstrapmill.com

CAPE ANN MARINE

SALES & SERVICE
978.283.0806
CapeAnnMarina.com

C-TRAP

MATT BORGES
MATTAPOISETT, MA
508.758.2740

CAPE CODDER MARINE, LLC

BOB DOBIAS
SWAMPSCOTT, MA
978.979.1795
capecodderboats.com

CAPE SEAFOODS BAIT DEALER

GERRY O'NEIL
GLOUCESTER, MA
978.479.4642

CAPE FISHERMEN SUPPLY

DAVE LIBBY
CHATHAM, MA
508.945.3501

CAPE TIP SEAFOODS

CHRIS KING
PROVINCETOWN/ORLEANS
508.487.0259 | 508.225.7221

CAPTAIN MARDEN'S SEAFOODS

KIM MARDEN
WELLESLEY, MA
781.329.7007 | 781.329.0792
captainmardens.com

CHERRY ST. FISH MARKET

DARRYL PARKER
DANVERS, MA
978.777.3449

CHRIS ELECTRONICS CORP.

FAIRHAVEN, MA
508.994.8257

COASTAL HYDRAULICS

RICH TUCKER
SEABROOK, NH
603.474.1914
coastalhyd.com
sales@coastalhyd.com

COHASSETT LOBSTER POUND

TOMMY ALIOTO
COHASSETT, MA
781.383.1551

EAST COAST SEAFOOD

SPIROS TOURKAKIS
LYNN, MA
781.593.1737

ECKLAND & BLANDO

SAM BLATCHLEY
BOSTON, MA 02110
617.217.6936 www.
ecklandblando.com

ELECTRA-DYNE CO INC.

JUDY MACCAFERRI
PLYMOUTH, MA
508.746.3270

FARM CREDIT EAST

MIDDLEBORO, MA
508.946.4455

FISHER AIR FASTENERS

ED & CHRIS FISHER
PEMBROKE, MA
781.826.2522

FISHERMEN SERVICES

DONNA CHEPREN
781.545.5073 Ext. 16
fishermenservices.com

FLEET PROPELLER SERVICE

MIKE VALM
FAIRHAVEN, MA
508.979.8000

FRIENDSHIP TRAP CO.

JERRY WADSWORTH
FRIENDSHIP, ME
800.451.1200

HAMILTON MARINE INC.

56 US ROUTE 1 BYPASS
KITTELY, ME 03904
207.439.1133
hamiltonmarine.com

HARBOR FUELS

info@harborfuels.com
617.720.3835

HERCULES

JOHN REARDON
NEW BEDFORD, MA
508.993.0010

JAMES HOOK & CO.

ED HOOK JR.
BOSTON, MA
617.423.5500

JOHN M. KARBOTT CUSTOM WOODEN BOAT BUILDING & REPAIR

PLYMOUTH, MA
508.224.3709
by-the-sea.com/
karbottboatbuilding

JOLIN LOBSTER

MANCHESTER, MA
978.526.7954

KETCHAM TRAPS

HEATHER KETCHAM
NEW BEDFORD, MA
508.997.4787

KINGFISHER TRAP

CARL HOWARD
DENNIS, MA
508.385.5968

KING LOBSTERS

D.J. KING
BRANFORD, CT
203.488.6926

KING MARINE LLC

CAPT. GEORDIE KING
MARINE SURVEYOR
207.337.8706
kinggeordie@comcast.net

LOBSTER CRUISES

PAUL QUINTAL
PLYMOUTH, MA
508.746.5342

LOBSTER TRAP FISH MARKET

MONUMET BEACH, MA
508.759.6400
lobstertrap.com

LOBSTER TRAP CO.

LOGAN CLARK
BOURNE, MA
508.759.4928
lobstertrap.com

LYNCH LOBSTER CO.

JOHN LYNCH
BEVERLY, MA
978.921.8088

MAIN STREET WIRE

DOUGLAS, MA
508.847.8888

MARINE HYDRAULIC ENGINEERING

ROBERT CROWE
ROCKLAND, ME
207.594.9525 | 800.747.7550

MILTON CAT POWER SYSTEMS

KEVIN HAMPSON
MILFORD, MA
508.207.8542

MORTILLARO LOBSTER, INC.

VINCE MORTILLARO
GLOUCESTER, MA
798.281.0959

NAHANT FISH & LOBSTER

781.592.7500

NAVROC MARINE ELECTRONICS

JASON PHILBROOK
ROCKLAND, ME
207.596.7803

N.E. MARINE & INDUSTRIAL INC.

MIKE RICHARDSON (NH)
603.436.2836 | 781.834.9301
Info@newenglandmarine.com

NEW ENGLAND PROPELLER

RON PECK
PLYMOUTH, MA
800.635.9504
neprop@aol.com

NORTH ATLANTIC POWER-TWIN DISC

SAM PROFIO
EXETER, NH
sprofio@glpower.com
603.418.0470

PIGEON COVE COOP

ROBERT MORRIS
978.479.3828

RFP LOBSTER BAIT

DICK PERENTZ
774.248.0292

RIVERDALE MILLS

NORTHBRIDGE, MA
508.234.8715

ROSES MARINE

MARTY BOLCOME
GLOUCESTER, MA
877.283.3334
rosesmarine.com

SEA CLIFF LOBSTER

FRANK COLLINS
MANOMET, MA
508.224.5700

SPURS MARINE MFG.

PABLO SOSA
FORT LAUDERDALE, FL
800.824.5372

SUPERIOR LOBSTER

MARSHFIELD-SANDWICH
774.773.5048
www.superiorlobster.com

THE NEW RESULT

LOUIS LARSEN
Mvseafood@vineyard.net

TWO COUSINS FISH MARKET

BRIAN O'DONOHUE
FREEPORT, NY
516.379.5065

WELLFLEET SHELLFISH CO.

508.255.5300
sales@wellfleetshell.com

WINDWARD POWER SYSTEMS

FAIRHAVEN, MA
774.992.0059
windwardpower.com

WOOD'S SEAFOOD

JAY KIMBALL
PLYMOUTH, MA
508.746.0261
www.woodsseafood.com

YANKEE FISHERMEN'S CO-OP.

SEABROOK, NH
603.474.9850

Make cleanup
easy and fast.

Blast Away!

Onboard Pressure Washers
5.6 GPM @ 3,500 PSI

Our pressure washers
come with everything you
need, including 50' hose and
wand with turbo nozzle.

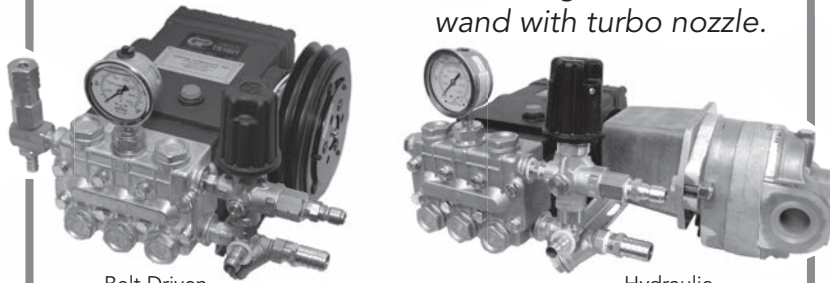

Belt Driven

Salt or Fresh Water

Hydraulic

Coastal Hydraulics, Inc.

603-474-1914 • sales@coastalhyd.com
www.coastalhyd.com
28 Route 286, Seabrook, NH



AUTO PARTS

CAPE COD

Auto, Marine, Truck & more
Talk to our Parts Professionals

FALMOUTH 508-548-6333 163 Worcester Court

HYANNIS 508-775-7552 949 Bearses Way

HYANNIS 508-771-6502 333 Barnstable Road

ORLEANS 508-225-0210 3 Nells Way

We make hydraulic hoses



THE *Specialists*
FROM BUOY TO TRAP

Built the Best, Built to Last,
Built Your Way.

PROVEN PERFORMERS! Rockbottom Runners



THEY MAKE
THE BEST
CRAB
TRAPS
TOO!!

Our precision formulation
and process has been
refined over the years
to provide the optimum
balance of strength and
flexibility... – and the
wise test shows it

Over **20 YEARS**
of fishing;

Well over **HALF**
A MILLION sold



Could you do this with
any other concrete runner?

Lite Load

SOLID STEEL CORE
- TOUGH POLYMER
COATING



Over
6 YEARS
of fishing.

Over a **QUARTER**
MILLION sold

GORILLA WOOD
RUNNERS

OCEAN-TESTED for years...
aircraft carrier decking and
pilings in the marine borer
intense Panama
Canal Zone.



The toughest species
of junglewood we've found
... and the only kind we sell.

We are constantly listening to our customers:
Your feedback + continuous improvement
= proven reliability

Here to serve you!

Jerry Wadsworth (207) 542-0842 jerryw@friendshiptrap.com

Jimmy Emerson (207) 483-6555 jemerson@friendshiptrap.com

Mike Wadsworth (207) 542-0841 mikew@friendshiptrap.com

Friendship Office: (800) 451-1200; (207) 354-2545

Columbia Falls Office: (800) 339-6558

Visit our website: www.friendshiptrap.com



Find us on:
facebook

Ketcham Supply Store Special

Riverdale Mills Patch Wire Off Grade

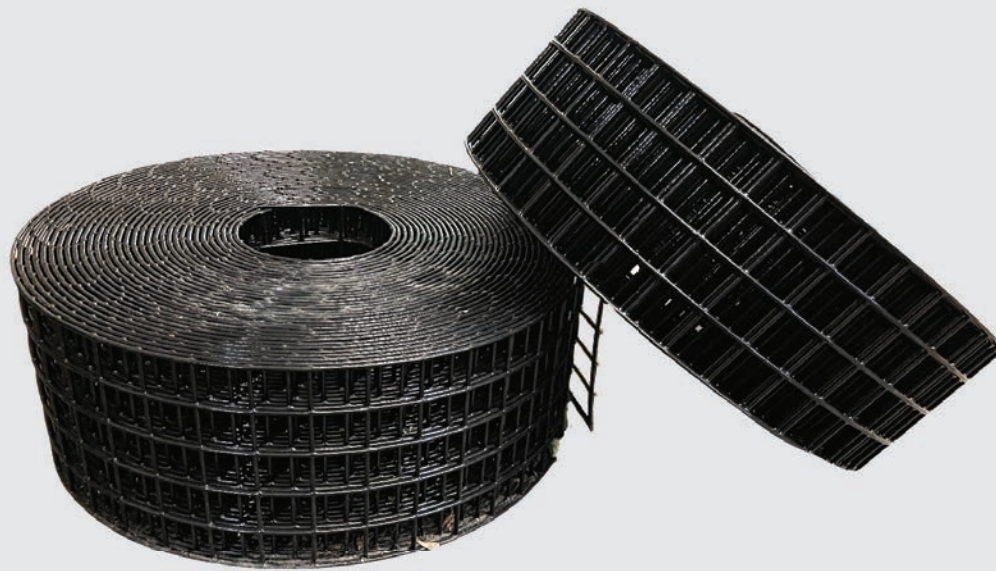

1.5" Mesh
12.5 Gauge
100' Roll

7.5 Inch (5 Mesh) Roll \$54

6 Inch (4 Mesh) Roll \$45

111 Myrtle Street
New Bedford, MA
🐦 @ketchamsupply



www.ketchamsupply.com
info@ketchamsupply.com
508.997.4787



Service Provider for MLA Non-Profit Boat Protection Cooperative Ltd.

MLA's #1 Commercial Boating Insurance Provider

Agreed Hull Value – Protection & Indemnity

Crew Coverage - Extended Policy Limits - Chartering

Marina Floaters - Multiple Fisheries - Deductibles

Call now for a free quote 781-545-5073

or

Request a quote online at fishermenservices.com



As the HAULER TURNS

The Massachusetts Lobstermen's Association would like to welcome the following new members to the Association. Your Association will continue its efforts on your behalf to conserve the resource, protect your livelihood, keep you informed, promote the industry and provide you with increasing benefits as they are developed. MLA stands ready to help you in anyway, at anytime — just let us know how! Safe on the water and good fishing!

NEW MLA MEMBERS:

ROBERT BRANDOLINI

F/V: Little Joe • Port: Haverhill



Published by the Massachusetts Lobstermen's Association, Inc.
8 Otis Place, Scituate, MA 02066

— Published monthly —

Mailed to all paid members of the Massachusetts Lobstermen's Association

Newsletter Departments

Editor, Industry News, Notice Section, Editorial, Blog, Industry News, Promotions, Layout, Advertising:
Beth Casoni — Executive Director

Buy Sell Swap: Tracey Abboud

Newsletter Advertising Rates

The MLA Newsletter is published monthly
(Please note that all pre-paid ads for last year will be honored)

\$50 — ¼ Page Ad

\$80 — ½ Page Ad

\$110 — Full Page Ad

Color Ads — + \$50 per ad



Now, as the commercial lobster season finally gets underway here in Massachusetts many of you have been asking about law enforcement and their efforts to enforce the right whale regulations or not. If last year was any indication that now, more than ever there needs to be a concerted effort by law enforcement to enforce all of these “new” right whale regulations as the MA Division of Marine Fisheries (DMF) is finishing up their application for the Incidental Take Permit (ITP), I don't know when would be the right time.

Unfortunately, for all of you who are compliant and have spent hundreds of hours reconfiguring your vertical-lines there are still many bad actors out there that believe they do not need to comply??? These individuals are jeopardizing your businesses and should be ashamed of themselves as the commercial lobster industry is hanging on by a thread as we are waiting for the outcome of the ITP application which, could take up to two years to be finalized. Massachusetts commercial lobstermen that are compliant cannot afford ANY offenders to be overlooked.

Gear markings, gear markings, gear markings oh my! The MLA in conjunction with the Lobster Foundation of Massachusetts are really close to having the MA LOBSTER tracer ribbon approved and into productions in the red and candy cane ropes.



Once this has been approved by NOAA, the DMF will take this out for rule making so that it can be used as a gear marking instead of the numerous 2' red marks should you choose to use this as a full vertical line. This will save you hundreds of hours marking your vertical lines. Many of you have suggested using a swivel at the buoy when using the red or candy cane rope so it doesn't hinkle up.

The MLA and LFoM will be holding splicing classes later this year and early next year to further help reduce the use of knots here in Massachusetts. Attendees at these classes will receive two coils of the new red and candy cane rope with the tracer for participating. Stay tuned!

Nowadays, every little bit helps and we need your help getting Amendment 187, Lobstering Closure Mitigation to the budget passed through the Massachusetts Senate and House. Amendment 187 will help get the commercial lobstermen here in the Commonwealth paid due to the forced closures for the protection of right whales.

Amendment 187 will create the Lobstering Closure Mitigation Fund within the Department of Unemployment Assistance. The fund would dispense payments to active licensed commercial lobster fishermen in amounts equal to one dollar per trap per week, retroactively

from February 1, 2022 through July 30, 2022.

Please have everyone you know call or email your local State Senator and Representative and ask them for their support on Amendment 187 Lobstering Closure Mitigation today! You can locate your legislators here <https://malegislature.gov/search/findmylegislator>

We are working on so many issues to help keep you fishing, somedays all I can do is shake my head as you can't make this \$hit up and there doesn't seem to be an end in sight! Someone once told me, “It's job security” and I politely responded, “It's insanity” and it is! All I keep telling myself is that the 1800 plus members of the Massachusetts Lobstermen's Association are why I keep doing what I do. Your thoughtful emails, texts and phone calls are truly appreciated as I keep telling you “I just keep swinging” and that's what I plan on doing, for you!

May you have a great June and know that I am here for you anytime you need, well not at 4:30am! I make myself available to all of you and for those of you that are new members, just reach out and say “Hi” once in a while so we can get to know each other and get connected. You are why I am here and I am so proud of who I work for, you!

Safe on the water,

Beth Casoni

Executive Director

President Biden signs American Fisheries Advisory Committee Act into law



WASHINGTON — On May 13th, President Biden signed into law Senate Bill 497, the “American Fisheries Advisory Committee Act,” which “requires the Department of Commerce to establish an American Fisheries Advisory Committee to assist in the awarding of fisheries research and development grants,” restore the voice of the fisheries’ most important stakeholders, and support the long-term vitality of American-caught seafood.

The Saltonstall-Kennedy (S-K) Act of 1954 established a program to provide funding for fisheries marketing, research, and development. The program is funded by a permanent appropriation of 30% of the previous calendar year’s customs receipts from imports of fish products. These funds have grown steadily from \$26.7 million in 1980 to \$182.8 million in 2020.

But since the early 1980s, Congress has directed NOAA’s Na-



tional Marine Fisheries Service (NMFS) to use these funds for stock assessments, fishing information networks, survey and monitoring projects, cooperative research, and “interjurisdictional functions.”

In 2021, only \$11 million was left for grants to support the fishing industry. Critics have questioned whether this allocation reflects the original intent of the S-K Act. To inform how grant funds are allocated, Congress originally authorized a group of experts from different segments of the fishing industry to advise on commercial fishing problems and needs.

Following a 1972 law, the original American Fisheries Advisory Committee was disbanded. In the committee’s absence, NMFS decides, by its own criteria, who receives grants. Critics have questioned whether the priorities of commercial fishermen match those of NMFS, and whether the S-K Grant Program is addressing the needs and priorities of the domestic fishing industry.

The American Fisheries Advisory Committee Act reestablishes a board of experts, with members chosen regionally and across all sectors of the fishing industry, to bring fishermen back into the process of identify-

ing needs and funding priorities. S. 497 was sponsored by Senator Dan Sullivan (R-Alaska), a member of the Senate Commerce, Science and Transportation Committee, and cosponsored by Senators Lisa Murkowski (R-Alaska), Elizabeth Warren (D-Mass.), Ed Markey (D-Mass.), Maria Cantwell (D-Wash.), Marco Rubio (R-Fla.), and Raphael Warnock (D-Ga.). More information about the Saltonstall-Kennedy grant program is available in this July 14, 2020 Congressional Research Service “Background and Issues” report by Harold F. Upton. May 13, 2022

<https://sgp.fas.org/crs/misc/R46335.pdf>

KITTERY PORTLAND ROCKLAND
SEARSPORT SW HARBOR JONESPORT

Our inventory is a mix of traditional and the latest in marine technology, representing a wide range of top marine manufacturers. We are the one-stop destination for all things boating and beyond.

HM₄**5**
YEARS
**HAMILTON
MARINE**
BOATERS' STORE™

REQUEST FREE
2022
Catalog

BOATERS STORE



 800-639-2715
 hamiltonmarine.com

Photo by Wayne Hamilton ©

REPOWER your boat with a new Cummins diesel engine.



QSB6.7
250-480 HP



QSC8.3
500 HP



QSL9
290-410 HP



QSM11
610 HP

Contact your local Cummins distributor or dealer for complete program details.

Steve Nadeau - MA, ME, RI and Upstate NY
207-510-2247 | steve.nadeau@cummins.com

Will Collins - MA, RI, CT and NY
781-801-1772 | will.collins@cummins.com

NETWORK OF MARINE ENGINE DEALERS THROUGHOUT NEW ENGLAND

Billings Diesel and Marine
Stonington, ME
(207) 367-2328

Great Bay Marine
Newington, NH
603-436-5299

James Rich Boat Yard
Southwest Harbor, ME
(207) 244-3208

Niemiec Marine
New Bedford, MA
(508) 997-7390

Brewers' Plymouth Marine
Plymouth, MA
(508) 746-4500

Gorham's Diesel Repair, Inc.
Braintree, MA
(781) 843-0816

Journey's End Marina
Rockland, ME
(207) 594-4444

Point Judith Marina
Wakefield, RI
(401) 789-7189

Brewer Greenwich Bay
Warwick, RI
(401) 884-0544

Hinckley Yacht Services
Portsmouth, RI
(401) 683-7100

**Kennedy Marine
Engineering & Fabrication**
Steuben, ME
(207) 546-7139

Port Niantic Inc
Niantic (East Lyme), CT
(860) 739-2155

Bristol Marine
Bristol, RI
(401) 253-2200

Hinckley Yacht Services
Southwest Harbor, ME
(207) 244-5572

Kingman Yacht Center
Cataumet, MA
(508) 563-7136

**Rhode Island
Engine Co., Inc.**
Narragansett, RI
(401) 789-1021

Cape Ann Marine
Gloucester, MA
(978) 283-2116

Hodgdon Yacht Services
Southport, ME
(207) 633-2970

**MacDougall's Cape Cod
Marine Service**
Falmouth, MA
(508) 548-3146

Russ Marine Service
Peabody, MA
(978) 532-3373

Casco Bay Diesel
Portland, ME
(207) 878-9377

Hyannis Marina
Hyannis, MA
(508) 775-5662

Merri-Mar Yacht Basin
Newburyport, MA
(978) 465-3022

Great Island Boat Yard
Harpswell, ME
207-729-1639

Independent Field Service
Dewitt, NY
(315) 481-4077

salesandservice.cummins.com

The Massachusetts Lobstermen's Association's Congratulations



to the Massachusetts Lobstermen's Associations' class of 2022. The recipients in memory of the Robert Wheeler scholarship are given to MLA members' children who are graduating high school and entering their first year of college.

This year's recipients are as follows;

Dylan Feeney from East Bridgewater, MA
will be attending Bridgewater State University to study psychology.

Nicole Nihtila from Holbrook, MA
will be attending Massasoit Community College
to study early childhood development.

We are certain that you all will have a fine future in your chosen fields of study and hope that you will keep in touch to let us know how you are doing.

*Best of luck to you all,
your friends at the Massachusetts Lobstermen's Association.*

Are you thinking of buying or selling?

Boats | State and Federal Permits | Complete Businesses

ATHEARN MARINE AGENCY, INC.



SERVING FISHERMEN SINCE 1946

Tel: (508) 999-4505

Email: sales@athearnmarine.com

www.athearnmarine.com

10 Union Wharf, Fairhaven, MA 02719



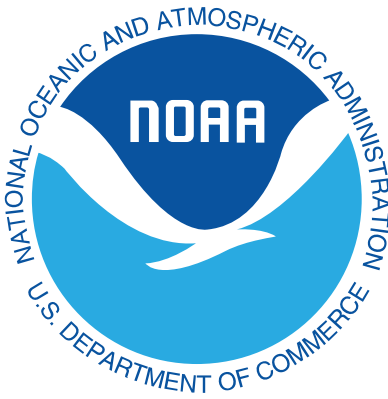

New global forecasts of marine heatwaves foretell ecological and economic impacts

The forecasts could help fishing fleets, ocean managers, and coastal communities anticipate the effects of marine heatwaves

Researchers have developed global forecasts that can provide up to a year's advance notice of marine heatwaves, sudden and pronounced increases in ocean temperatures that can dramatically affect ocean ecosystems.

The forecasts described in the journal *Nature* could help fishing fleets, ocean managers, and coastal communities anticipate the effects of marine heatwaves. One such heatwave, known as "the Blob," emerged about 2013 in the north-

east Pacific Ocean and persisted through 2016. It led to shifting fish stocks, harmful algal blooms, entanglements of endangered humpback whales, and thousands of starving sea lion pups washing up on beaches.

"We have seen marine heatwaves cause sudden and pronounced changes in ocean ecosystems around the world, and forecasts can help us anticipate what may be coming," said lead author Michael Jacox, a research scientist at NOAA Fisheries' Southwest Fisheries Science Center in Monterey, California, and NOAA's Physical Sciences Laboratory in Boulder, Colorado.

Marine heatwave forecasts will be available online through NOAA's Physical Sciences Laboratory. The researchers called the forecasts a "key advance toward improved climate adaptation and resilience for marine-dependent communities around the globe."

The forecasts leverage global climate models to predict the likely emergence of new marine heatwaves. "This is a really exciting way to use existing modeling tools in a much-needed new application," Jacox said.

REDUCING ECOLOGICAL AND ECONOMIC IMPACTS

Impacts of marine heatwaves have been documented in ecosystems around the world, particu-

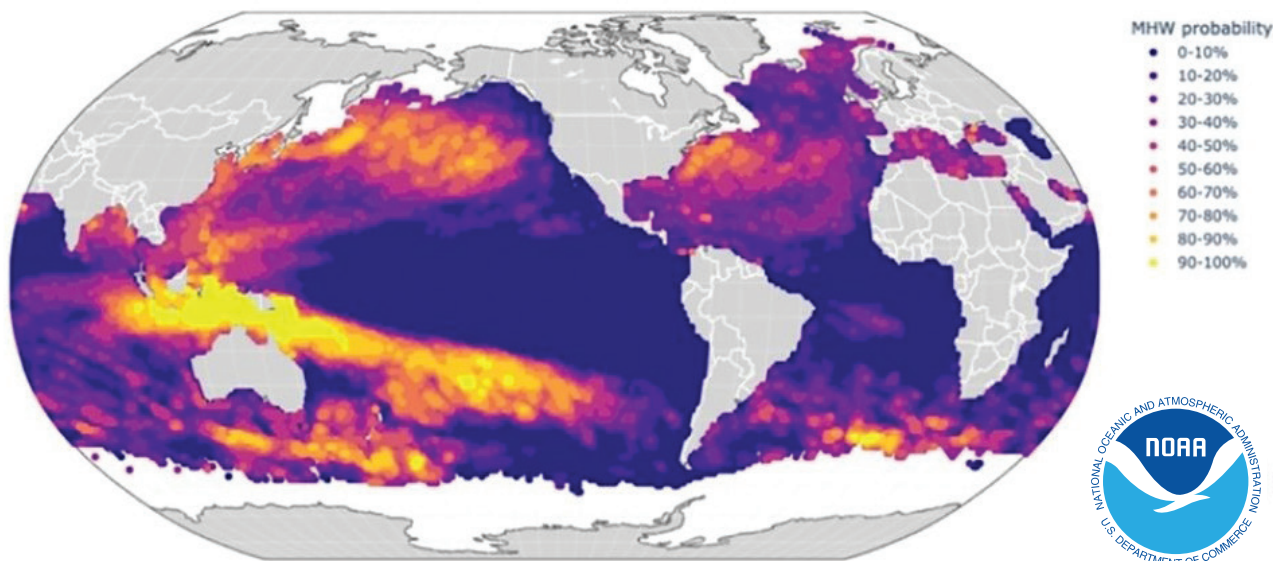

The latest global marine heatwave forecast showing the predicted probability of marine heatwaves for September 2022. Forecasts are experimental guidance, providing insight from the latest climate models. To see the latest marine heatwave maps and forecasts, visit NOAA's Physical Sciences Laboratory's Marine Heatwaves page.

larly in the past decade. These include:

- Fish and shellfish declines that caused global fishery losses of hundreds of millions of dollars
- Shifting distributions of marine species that increased human-wildlife conflict and disputes about fishing rights
- Extremely warm waters that have caused bleaching and mass mortalities of corals

On the U.S. West Coast, marine heatwaves gained notoriety following the Blob, which rattled the California Current Ecosystem starting in 2014. That marine heatwave led to an ecological cascade in which whales' prey was concentrated unusually close to shore, and a severe bloom of toxic algae along the coast delayed opening of the valuable Dungeness crab fishery. Humpback whales moved closer to shore to feed in some of the same waters targeted by the crab fishery. As fishermen tried to make up for lost time after the delay by deploying additional crab traps, whales became entangled in record numbers in the lines attached to crab traps. Recent research has also connected marine heatwaves along the West Coast to a northward shift in California market squid, which have long supported one of California's largest commercial fisheries.

NOAA Fisheries scientists have since developed a Marine Heatwave Tracker that monitors the North Pacific Ocean for signs of marine heatwaves. The forecasts go a step further to anticipate where marine heatwaves are likely to emerge in coming months, and how long they are expected to persist.

"Extreme events in concert with increasing global temperatures can serve as a catalyst for ecosystem change and reorganization," said Elliott Hazen, a research ecologist at the Southwest Fisheries Science Center and coauthor of the research. "While marine heatwaves can have some unanticipated effects, knowing what's coming allows for a more precautionary approach to lessen the impact on both fisheries and protected species. Understanding the ocean is the first step towards forecasting ecological changes and incorporating that foresight into decision-making."

EL NIÑO-SOUTHERN OSCILLATION BOOSTS FORECAST ACCURACY

The forecasts are most accurate during periods influenced by the El Niño-Southern Oscillation, a well-known climate pattern in the Pacific Ocean. In fact, El Niño (the warm phase of the oscillation) could be considered the "world's most prominent marine heatwave," Jacox said. It demonstrates that the heatwaves themselves are not new.

The forecasts cannot predict marine heatwaves as far in advance in regions such as the Mediterranean Sea, or off the U.S. East Coast. The atmosphere and ocean fluctuate more rapidly in these areas. The forecasts provide the greatest foresight in areas with known ocean-climate patterns such as the Indo-Pacific region north of Australia, the California Current System, and the northern Brazil Current.

The scientists noted that managers of fisheries and other marine life must weigh their reaction to predicted marine heatwaves based on the potential consequences. For example, they would need to weigh the economic costs of limiting fisheries ahead of a marine heatwave against the risk of inadvertently entangling endangered whales or sea turtles.

"We're talking about the difference between making informed choices and reacting to changes as they impact ecosystems," Hazen said. "That is always going to be a balance, but now it is a much more informed one."

The research is a collaboration between scientists at:

- NOAA Fisheries' Southwest Fisheries Science Center
- NOAA Research's Physical Sciences Laboratory
- University of Miami
- University of California - Santa Cruz

The work was supported by funding from the NOAA Climate Program Office's Modeling, Analysis, Predictions and Projections program and the NOAA Fisheries' Office of Science and Technology.

<https://www.fisheries.noaa.gov/feature-story/new-global-forecasts-marine-heatwaves-foretell-ecological-and-economic-impacts>



FISHING PARTNERSHIP



SUPPORT SERVICES

Mission

To improve the health, safety and economic security of commercial fishermen and their families.

Fishing Partnership Navigators are certified community health workers who can assist MA residents with applying for health insurance, updating income, and finding a primary care physician. You may be eligible to enroll in health insurance anytime during the year. Reach out to a Navigator today to explore all your options.

NAVIGATOR OFFICES:

Gloucester
978-282-4847

Plymouth
508-746-5400

New Bedford
508-991-3043

Chatham
774-840-9393

Massachusetts maintains a mandate for all individuals to have health insurance. Unenrolled residents could pay a tax penalty. Don't risk it - call a Navigator and get covered today!

Follow



617-928-3443
fishingpartnership.org





Cape Seafoods Bait Shop Kicking off the Season!

THE LARGEST BAIT VARIETY IN THE ATLANTIC NORTHEAST

In operation since 2001 and still going strong!

Trust Us for Your Fresh, Salted & Frozen Bait Needs

From (1) Carton to a Full Truck Load.

**Herring, Mackerel, Pogies, Redfish, Rockfish, Tuna, Monkfish, Sardines,
Plaice, Squid, Sea Robin, Halibut, & Silversides.**

We've got you covered!

Great News...We now buy Lobster, too!

Open Year Round (Serving clients 7 Days a Week from Mid-June To Mid-October)

Monday-Friday 5AM-3PM, Saturday 6AM-12PM & Sunday 6AM-10AM

Main Phone Line: 978.283.8522

Bait Shop Phone Line : 978.479.4642

If we don't have it... Please ask and we'll find it!

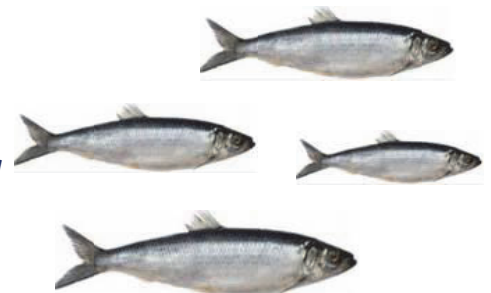



New England Marine Engineering & Supply, Inc.

Marine • Industrial • Commercial • Refrigeration

10 TON ELECTRIC TITANIUM RSW
INTEGRATED MARINE SYSTEMS

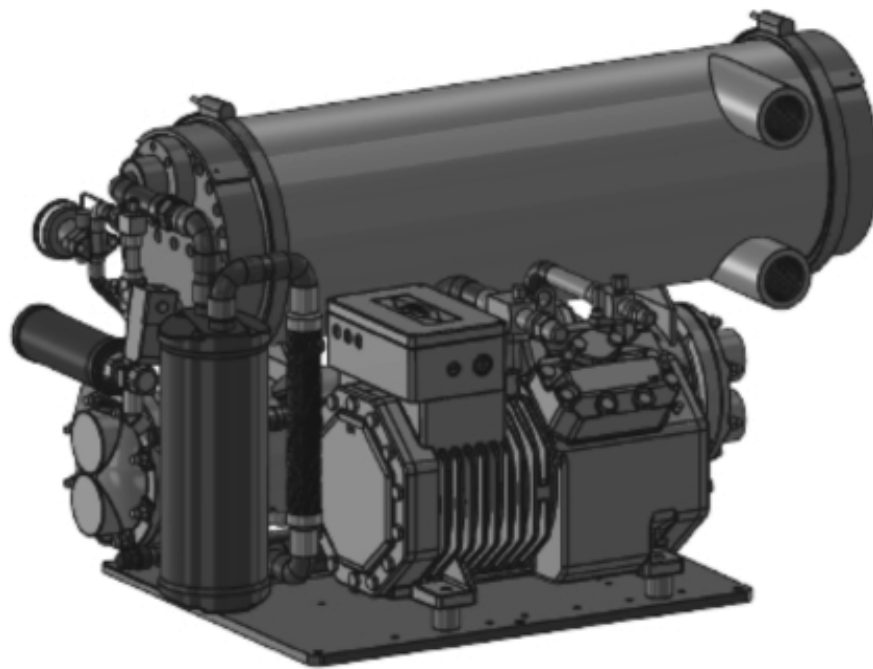

"New England Marine Engineering & Supply, Inc & Integrated Marine Systems, Inc is proud to announce & debut the new IMS 10 Ton Titanium Electric RSW at the 2018 Seafood Processing North America Show on March 11-13 Booth 1875. Come see us and be the first to view the latest IMS system to be introduced to the industry for the fishing vessels ranging from 40' - 80'.

It's going to be the talk of the show."

133 North Front Street, New Bedford, MA. 02740

www.nemesinc.com 1.800.540.8893



New England Fishery Management Council

FOR IMMEDIATE RELEASE
May 3, 2022

PRESS CONTACT: Janice Plante
(607) 592-4817, jplante@nefmc.org

EBFM Outreach Ramping Up: Watch the Five-Minute Video, View the Infographics, Check out the Brochures

The New England Fishery Management Council is preparing to conduct public information workshops in six different fishing ports to help fishermen and other stakeholders better understand what ecosystem-based fishery management (EBFM) is all about. These workshops, which are under development, are expected to be held later this summer or early fall.

In the meantime, the Council is encouraging people to become familiar with the extensive array of outreach materials posted on the EBFM public information [outreach webpage](#). Here are some highlights.

- Watch the [five-minute introductory video](#) (see below).
- Click on the **Stakeholder Brochures and Presentations** on the EBFM [outreach webpage](#).
- Check out the [EBFM Glossary of Terms](#).



What is EBFM?
Find Out [HERE!](#)

Listen to What People are Saying About EBFM



How Do I Watch the Video?

The video is available by webinar. Follow these three easy steps.

1. Click [HERE](#).
2. Fill out your name and email address.
3. Click on “Join Webinar” and the video will begin.

The Council, in concert with several stakeholders and contracted support from [Green Fin Studio](#), produced a [five-minute introductory video](#) to give viewers a glimpse into what people are saying about EBFM. The video touches on the potential benefits of EBFM and gives stakeholders a chance to raise questions and concerns about the challenges and unknowns. Speakers also talk about possible trade offs between single-species management versus ecosystem management. The video provides a simple overview of this complex topic.



New England Fishery Management Council

The Council has been exploring ecosystem-based fishery management for several years now. The upcoming public information workshops are intended to help inform fishermen and other stakeholders about EBFM and its potential application to a Georges Bank Ecosystem Production Unit. The Council has been referring to this approach as an example Fishery Ecosystem Plan for Georges Bank, which often is simply called the eFEP.

➤ [Here is a guide to the eFEP for Georges Bank.](#)

During its April 2022 meeting, the Council received a progress report on the latest EBFM outreach efforts and workshop planning. Another update is planned for the June 2022 meeting.

The Council also received an update on work being done to develop a simplified, prototype management strategy evaluation (pMSE) for EBFM. This trial, dry-run prototype is intended to demonstrate how a larger-scale MSE eventually could be used to evaluate EBFM management strategies for a Georges Bank Ecosystem Production Unit with all stakeholders involved. The Council approved the planning document for this initiative.

The presentation and other meeting materials related to the April EBFM discussion are available here.

Questions? Contact Andrew Applegate, the Council's EBFM coordinator, at (978)465-0492, ext. 114, aapplegate@nefmc.org.

Pop Open the Easy-to-Read Infographics

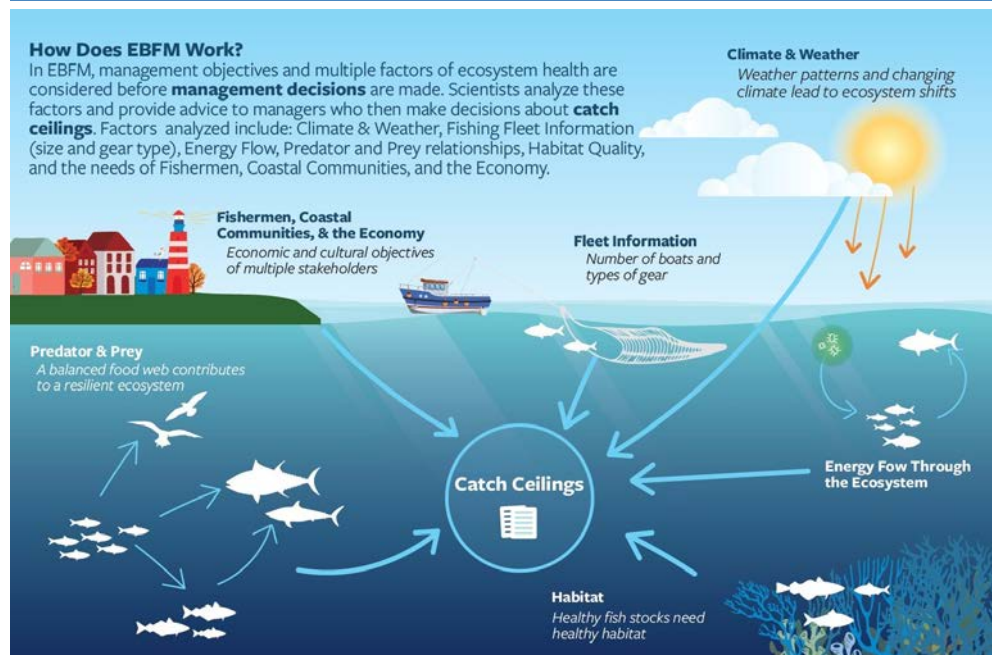

The above diagram is from the infographic titled “What is EBFM?” A second infographic titled “Georges Bank Ecosystem Production Unit” also is available on the outreach webpage.



During its April meeting, the Council received a presentation from the Northeast Fisheries Science Center on the 2022 State of the Ecosystem for New England.

The Council's Scientific and Statistical Committee provided feedback on the report.

AQUAMESH®

by Riverdale Mills

Servicing all your wire needs



1.508.234.8400 | 1.800.762.6374
sales@riverdale.com | www.riverdale.com



The Lobster Foundation of Massachusetts gets \$40K grant for Mass lobstermen education project



On March 16th, 2022, the Lobster Foundation of Massachusetts, (LFoM) received a \$40,000 grant from the Massachusetts Environmental Trust (Trust), **Drive for a Better Environment** grant program.

This financial boost will benefit the project, “*Providing MA Lobstermen with Education and Tools for Marine Mammal Conservation*”.

The project will provide education and outreach to Massachusetts lobstermen on the requirements and proper use of new buoy marking requirements, as well as support the use of weaker red and candy cone rope by teaching rope splicing/insertion skills for use as approved weak contrivances.

In partnership with the Massachusetts Lobstermen's Association, (MLA), the LFoM and the MLA are continuing in their efforts of conservation on behalf of the North Atlantic Right Whale and all marine mammals.

The LFoM will continue to uphold its commitment to scientific research, conservation and educational outreach that promote sustainability and safe fishing practices.

The LFoM and the MLA strongly encourage supporting the environmental programs funded by the Trust in your community.

There are three environmental plates to choose from; the Right Whale & Roseate Terns, The Leaping Brook Trout, or the Blackstone Valley Mill when you purchase or lease a new car or renew your registration with the Registry of Motor Vehicles.

Visit your local Registry of Motor Vehicles to order a plate online at www.massrmv.com or www.whaleplate.org. You can also visit www.mass.gov/eea/met to learn more about the Trust, the programs it supports, and the specialty license plate offerings.









New England Marine & Industrial
www.newenglandmarine.com

Lobster Bands

We carry:

Sheddar

Standard

Cold Water Shedder

Jumbo



Buy them by the 1 pound bag, by the case or by the pallet. We also offer wholesale and volume discounts. Call and ask to speak to a salesman.



Dayglo &
Flexabar
Buoy Paint



Perone Buoys

Full selection of sizes
in Stock

Riverdale/Aquamesh Trap Wire

- Large inventory of trap wire in store
- Variety of sizes and colors available
 - Some trap kits in stock
- Order any size trap kits you may need

200 Spaulding Tpke
Portsmouth, NH
603-436-2836

294 Ocean St
Brant Rock, MA
781-834-9301

86 Cemetary Rd
Stonington, ME
207-367-2692

Relief

FROM PAGE 1

“Lobstering and commercial fishing is part of the fabric of this community,” Kearney (D-Marshfield) said Friday. “It’s important that we at the state level set up this fund so, in the time of forced closure, they are able to provide for their families and stay in the communities they work and live in.”

O’Connor said the idea for the budget amendment came out of a conversation with Patriot Ledger photographer Greg Derr, who has been covering the communities of Marshfield and Scituate for decades.

“Greg said it was a shame we were not doing something for lobstermen like we were



State Rep. Joan Meschino, State Senator Bruce Tarr, MLA Executive Director Beth Casoni, State Senator Patrick O’Connor, State Rep. Patrick Kearney

doing for other gig industries,” O’Connor said. “A lot of the things I do just come from conversations I have with constituents. Greg had no financial bearing here, he just wanted to make sure these families were taken

care of, and he was right.”

If passed, the budget amendment would allocate \$12 million to retroactively paying lobstermen for this year’s closure and set up a regular budget item to be

funded each year. If it does not pass, O’Connor said he plans to file the idea as a standalone bill.

“Massachusetts is flush with cash right now. Last month alone we had a \$2 billion budget surplus, so asking for \$12 million to help families on the South Shore and across the state seems very reasonable,” O’Connor said.

This story by Mary Whitfill originally appeared on May 20, 2022 in The Patriot Ledger.

Reach Mary Whitfill at mwhitfill@patriotledger.com

<https://www.patriotledger.com/story/news/2022/05/20/budget-amendment-aims-pay-south-shore-lobstermen-off-season/9846679002/>

OVER 20 YEARS EXPERIENCE ~ ALL MATERIALS & SIZES

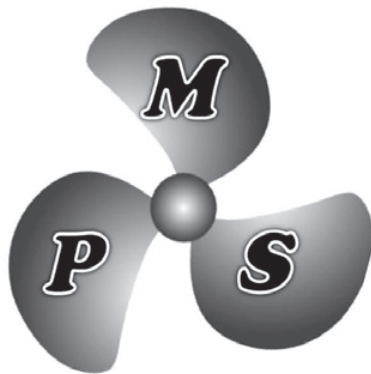

**FOR FAST SERVICE
CALL MIKE @
508.979.8000**

marine.propeller128@gmail.com

MARINE
PROPELLER SERVICE

REPAIRS &
RECONDITIONING
(Fast & Fully Insured)



THE MOST RELIABLE PROPELLER SERVICE COMPANY ON THE SOUTHCOAST

74 MAIN STREET FAIRHAVEN MA 02719 508.979.8000 FAX 774.206.6449

Massachusetts Buoy Line Marking Examples

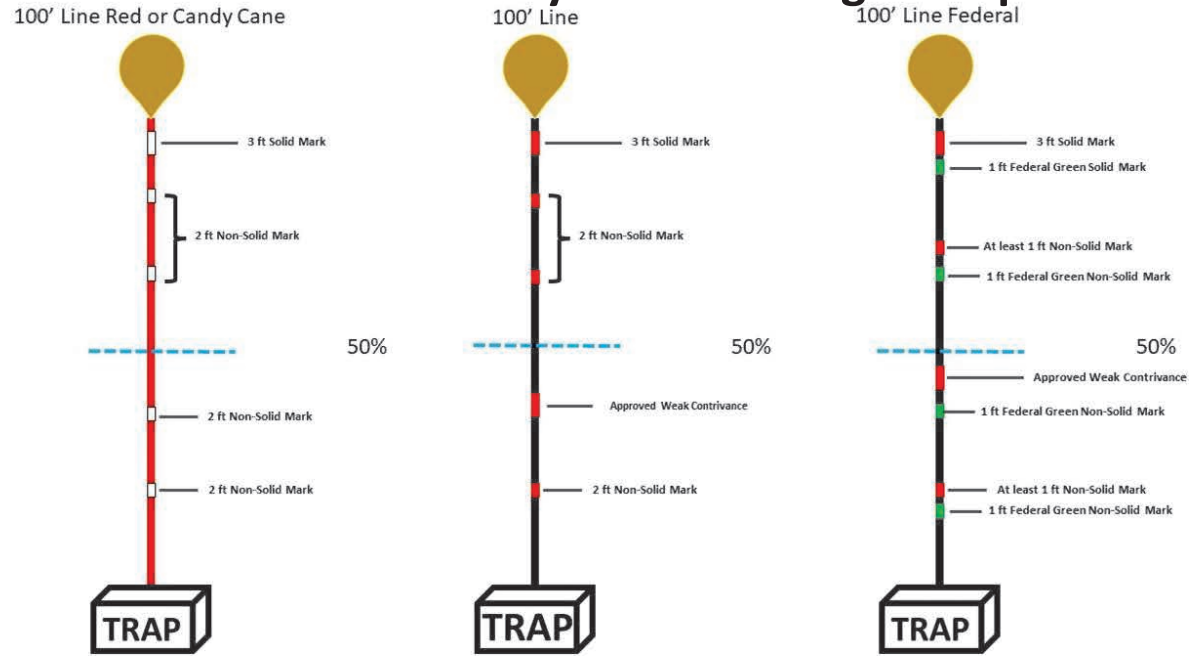

- A vertical line is a buoy line begins at the buoy and extends to the first trap on a single, or in the case of a trawl begins at the buoy and ends at the groundline.
- One **SOLID RED** (or **WHITE**) mark at 3 feet in length within 1st 2 fathoms (12 feet) of the buoy
- Weak contrivances must occur every 60 feet in the **TOP 75%** of the buoy line. If using plastic links as contrivances, an additional gear mark will be needed.
- If fishing approved, fully formed weak rope in the **TOP 75%**, **NO** contrivances are required
- If a splice of red or candy cane weak rope or a South Shore Sleeve with a red tracer is used, then that contrivance may double as a buoy line mark
- Guides to Contrivances can be found at: <https://media.fisheries.noaa.gov/2021-11/Massachusetts%20Summary%2011152021.pdf>
- Minimum of **TWO RED** (or **WHITE**) **NON-SOLID** marks each being at least 2 feet in length in the top 50% of the buoy line.
- Minimum of **TWO RED** (or **WHITE**) **NON-SOLID** marks each being at least 2 feet in length in the bottom 50% of the buoy line
- No length of buoy line **GREATER** than 60 feet **WITHOUT** a mark is allowed, marks must be adjusted accordingly if the line is **LONGER** than 100 feet
- If fishing within **FEDERAL** waters, a 1-foot **GREEN SOLID** mark is required within **6 INCHES** of **EVERY RED SOLID** mark.
- If fishing within **FEDERAL** waters, after every **NON-SOLID RED** mark, a **NON-SOLID GREEN** mark is required



Encore Hartco Tools & Clips
 Stanley Spenax Tools & C-Rings
 Wematic Tools & D-Rings
 Simonds Pneumatic Wire Cutters
 Spotnail Staplers & Staples



(781) 826-2522
 Fax (781) 826 5252
www.fisherairfasteners.com
chris@fisherairfasteners.com

Complete Parts Inventory
 Tool Repair Service

HERCULES
SLR (US) Inc.
MARINE • FISHING GEAR • SAFETY

44 South Street, New Bedford, MA 02740
Phone: 508-993-0010 Fax: 508-993-9005
Securing - Lifting - Rigging
82 MacArthur Dr. New Bedford, MA 02740
Phone: 508-992-9519 Fax: 508-992-9419

JohnReardon@Hercules-SLR-US.com

USCG Safety Inspection Station #327

Commercial Fishing-Marine Safety-Rigging

- ❖ Marine Hardware
- ❖ Cotesi - Netting, Leaded/Sink Rope
- ❖ Stormline & Climate Technical-Foul Weather Gear
- ❖ Buoys & Floats
- ❖ Lobster Bands
- ❖ PFD's, Vests, Float Coats
- ❖ Fish Totes
- ❖ Insulated Tubs
- ❖ Cordage & Twine
- ❖ Mooring Equipment
- ❖ Boarding Ladders
- ❖ Polysteel Rope- Esterpro Sinking, Hydropro
- ❖ Leadline
- ❖ Wire Rope - FC Galv, IWRC, Dyform
- ❖ HiFlyers 12', 14' & 15' XHD
- ❖ Golf & Batting Cage Netting



Inflatable PFD's



Life Raft Sales

- ❖ Revere
 - ❖ Elliot
 - ❖ Survitec
 - ❖ Switlik
- All brands accepted for service



Fenders & Buoys-All Colors



ACR Electronics
Sales & Service
for your E.P.I.R.B.



Boots from
Honeywell Safety

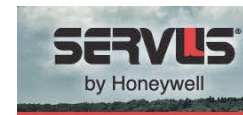

On-Board Vessel Inspections & Safety Drills

Call our USCG Certified Drill Conductors:

Rodney Avila 508-889-0401

Ted Williams 508-264-5779



Imperial
Survival Suits
Sales & Annual
Inspections
Done in house

"PULL THE PIN AND THROW IT IN"



DSPA 5 M

OUR NEWEST FIRE PROTECTION

www.Hercules-SLR-US.com

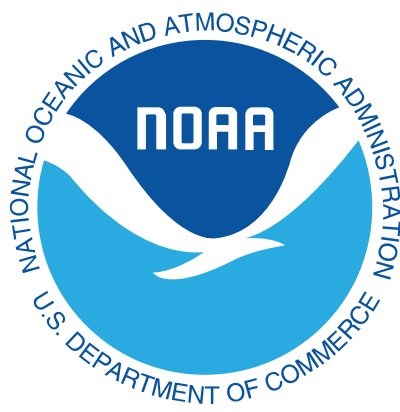

United States fish stocks continue era of rebuilding and recovery

New tools and data support fishery management in the face of a changing climate

Today, NOAA released the 2021 Status of Stocks report, highlighting the efforts to rebuild and recover U.S. fisheries by providing a snapshot of the more than 460 stocks managed by NOAA Fisheries. In addition, NOAA issued an update to the Fisheries of the United States report, which provides details about the economic impacts of fisheries, and tracks annual seafood consumption and the productivity of top fishing ports.

In 2021, U.S. fisheries held steady with more than 90% of

stocks not subject to overfishing, and 80% with population sizes sufficient to be considered not overfished. The number of stocks on the overfishing list held steady at 26, and the number of overfished stocks slightly increased to 51, up from 49. Data also reveals that in 2020, seafood landings in the U.S. were down 10% — likely due to the impacts of the COVID-19 pandemic — and overall seafood consumption had slightly decreased from the previous year, to 19 pounds per person.

A stock is on the overfishing list when the annual catch rate is too high. A stock is on the overfished list when the population size of a stock is too low, whether because of fishing or other causes.

“NOAA’s annual Status of Stocks report shows that the United States continues to be a global leader in sustainable fisheries management, as we work to understand how climate change is affecting fisheries and the communities that this sector supports,” said Dr. Rick Spin-

rad, NOAA Administrator. “The report demonstrates that we remain on track to maximize marine fishing opportunities while ensuring long-term ecological and economic sustainability in our changing world.”

This year’s report also featured the first-ever assessment of the Atlantic blacktip shark. NOAA Fisheries determined the stock is not subject to overfishing, not overfished and is above the sustainable level. Assessing stocks for the first time significantly contributes to the

322 Stocks with Known Overfishing Status

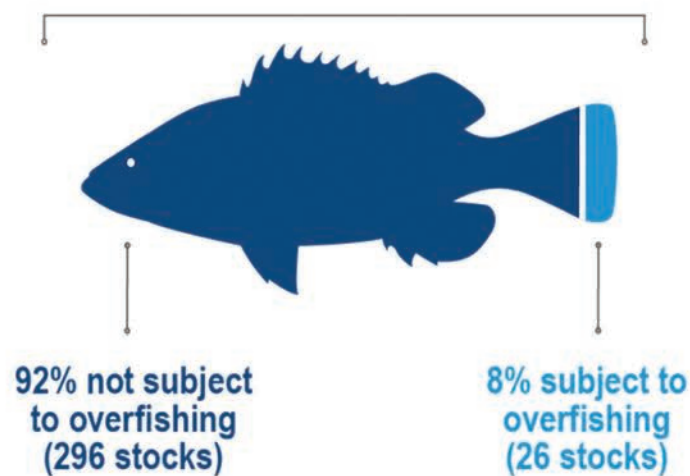

252 Stocks with Known Overfished Status

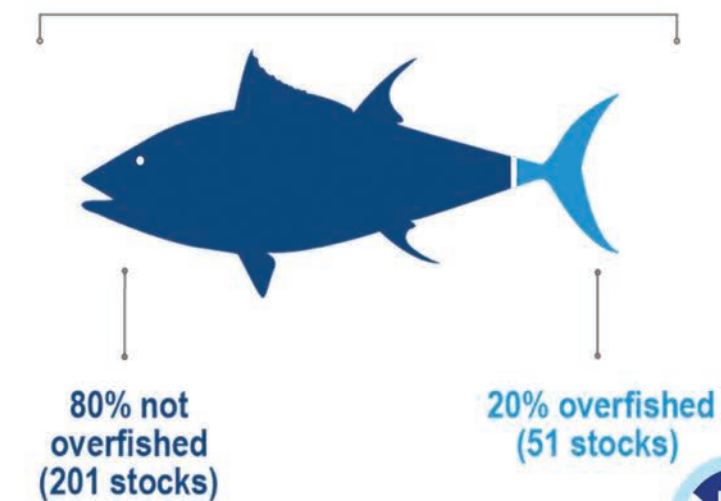

Of the more than 460 stocks managed by NOAA, 322 have a known overfishing status (296 not subject to overfishing and 26 subject to overfishing) and 252 have a known overfished status (201 not overfished and 51 overfished). (NOAA)



U.S. Commercial Fisheries and the Seafood Industry Landings and Values, 2020

National
Totals



8.4

billion pounds
-10% from 2019

\$4.8

billion
-15% from 2019



U.S. fishermen at ports in the 50 states landed 8.4 billion pounds valued at \$4.8 billion in 2020. (NOAA)

science-based information used to set appropriate management measures.

“Maintaining sustainable fisheries contributes significantly to the U.S. economy and helps meet the growing challenge of increasing our nation’s seafood supply,” said Janet Coit, NOAA Fisheries Assistant Administra-

tor. “This year, improved methodologies, updated stock assessments and innovative tools and approaches provided new information to inform fisheries management in the face of climate change.”

For the first time, Fisheries of the United States data is now available via a new interactive

web portal, which includes a detailed historic record of economic analysis of seafood consumption, landings totals and imports and exports of fishery products in the U.S. This portal will allow for more frequent updates throughout the year to improve data sharing and collaboration.

In April, NOAA Fisheries also

shared a new tool to better track the location and movement of marine fish and invertebrate species in U.S. waters, which may be shifting in response to changing ocean conditions. This resource facilitates decision-making about fishery management and science, and increases overall knowledge of species distributions for stock assessments.

Sustainable U.S. fisheries play an important role in the nation’s economy, providing opportunities for commercial, recreational and subsistence fishing, and sustainable seafood for consumers. By ending overfishing and rebuilding stocks, NOAA Fisheries strengthens the value of U.S. fisheries to the economy, communities and marine ecosystems.

Media Contact - Lauren Gaches,
nmfs.pa@noaa.gov,
(202) 740-8314

<https://www.noaa.gov/news-release/us-fish-stocks-continue-era-of-rebuilding-and-recovery>

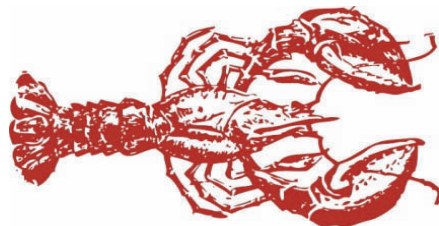

“Specializing in the sale & delivery of
LOBSTER BAIT
for over 30 years”

FRESH FROZEN AND SALTED BAIT AVAILABLE

**SKATES ~ HERRING ~ POGIES ~ HADDOCK ~ COD FISH ~ POLLOCK
FLAT FISH ~ FISH SKINS ~ RED FISH ~ DOG FISH HEADS ~ SALMON**



C & P BAIT
33 Wright St
New Bedford, MA 02740

Contact:
Danny Costa 508-951-9818
Carlos Pereira 508-951-9819



Rose Marine

Gloucester, MASS www.rosesmarine.com

877-283-3334

Aqualoy Stainless Propeller Shafts & Accessories



Largest stock of **Aqualoy** Stainless Prop Shafting on the East Coast
With *Emergency* turn-around time available.

Call or e-mail Peter Tetrault for a price on your next shaft.
peter.tetrault@rosesoil.net



- All Seamless Tubing
- High pressure available
- 90/10 copper-nickel
- 2" to 5" Dia. Body in stock



- Stainless Steel Wrapped
- Teflon Core
- Super Low friction

Ask for the "GREEN MARINE" cable

KOBELT
Controls



Anchor Flush Mount Hatches

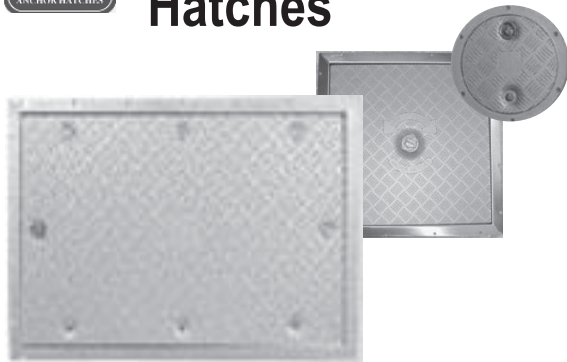

Mufflers and Exhaust Components



Stainless Steel Mufflers
And Accessories
2" - 8" inlet size in stock





Rose Marine

Gloucester, MASS www.rosesmarine.com

877-283-3334

Sales and Service of Hydraulic Components

We will customize a hydraulic hauling or power-steering system to fit your exact needs.

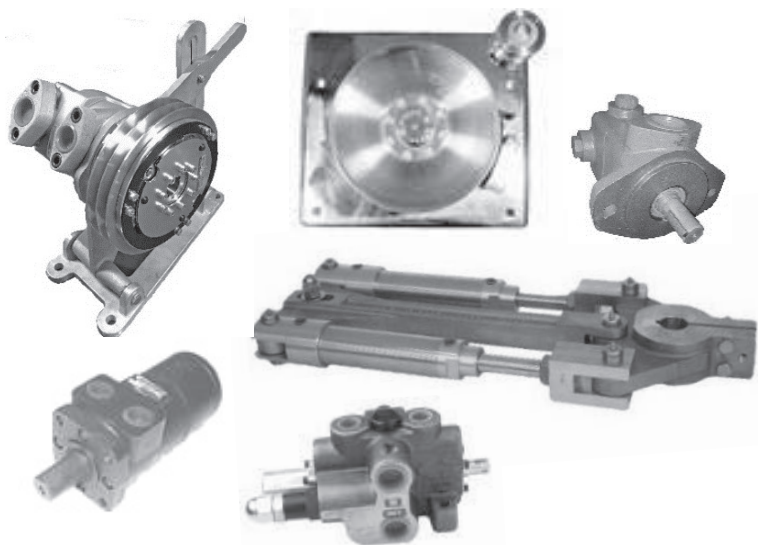

Authorized SEASTAR Solutions (FORMERLY Teleflex)
Repair Facility for the Northeastern U.S.



Complete Line of
Johnson Pump®
Pumps & Parts

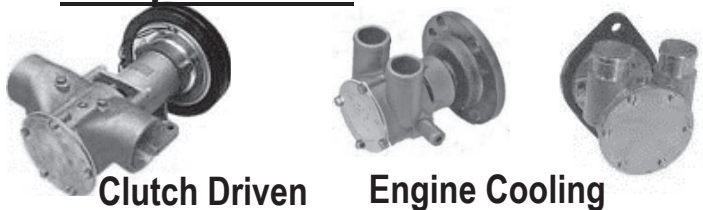

Clutch Driven

Engine Cooling



Complete Line of
PAGER
Pumps & Parts

Hydraulic Driven

Sized to the flow rate to fit your boat.

PACKLESS SEALING SYSTEM
SHAFT SEAL



Stocking Distributor

Combination Shaft Zinc & Line Cutters



Shaft Sizes
3/4" to 2-1/4"





Atlantic States Marine Fisheries Commission NEWS RELEASE

FOR IMMEDIATE RELEASE: May 5, 2022 | PRESS CONTACT: Tina Berger, 703.842.0749

ASMFC presents Annual Awards of Excellence for 2020 and 2021

ARLINGTON, VA — The Atlantic States Marine Fisheries Commission presented its Annual Awards of Excellence to an esteemed group of fishery managers, scientists, stakeholders and law enforcement officers for their outstanding contributions to fisheries management, science, and law enforcement along the Atlantic coast. Specifically, the award recipients for 2020 and 2021 were Lynn Fegley and Derek Orner for management and policy contributions; Rich Wong, Jimmy and Bobby Ruhle, and a subset of the Atlantic Menhaden/Ecological Reference Points Team for technical and scientific contributions; Greg DiDomenico for outreach and advocacy contributions; and Captain Michael Eastman, Special Agents Chris McCarron and Steven Niemi, and Enforcement Officer Timothy Wilmarth for law enforcement contributions.

“Every year a great many people contribute to the success of fisheries management along the Atlantic coast. The Commission’s Annual Awards of Excellence recognize outstanding ef-

forts by professionals who have made a difference in the way we manage and conserve our fisheries,” said ASMFC Chair Spud Woodward of Georgia. “I am humbled by the breadth and extent of accomplishments of the recipients and am grateful for their dedication to Atlantic coast fisheries.”

MANAGEMENT AND POLICY CONTRIBUTIONS

Lynn Fegley,
Maryland Department of Natural Resources

It is impossible to overstate Lynn Fegley’s contributions to the Commission and her leadership in interstate fisheries management and coastwide data collection. Her notable accomplishments include work on the implementation of ecosystem-based reference points in the management of Atlantic menhaden; writing and implementing Maryland’s CARES Act Spending Plan; serving as an active member of the South Atlantic

State/Federal Fisheries Management Board and subsequently the recently established Sciaenids and Pelagics Manage-

ment Boards; and leading the discussion to improve accountability in coastwide harvest data standards while Chair of the Atlantic Coastal Cooperative Statistics Program Coordinating Council. Highly knowledgeable about and committed to effective interstate fisheries management and policy, Ms. Fegley consistently shows her dedication to hard work, scientific rigor, and integrity in all that she does.

Derek Orner,
NOAA Fisheries

A valued federal partner for many years, Derek Orner has served as NOAA Fisheries’ lead on numerous Commission management boards and committees, including those for striped bass, shad and river herring, and Atlantic menhaden, providing sound advice and guidance on the management of these species. Additionally, Mr. Orner has played a critical role to the ongoing success of interstate fisheries management through his efforts to ensure the Commission and states consistently receive their appropriated funding from Congress in a timely manner. He has a keen

understanding of the Atlantic Coastal Fisheries Cooperative Management Act and a strong commitment to state/federal partnership, as exemplified by his contributions to the recently signed interagency Memorandum of Understanding between NOAA Fisheries, the U.S. Fish and Wildlife Service and the U.S. Geological Survey.

SCIENTIFIC AND TECHNICAL CONTRIBUTIONS

Dr. Rich Wong,
Delaware Division of Fish and Wildlife

During Rich Wong’s 17-year career with Delaware Division of Fish and Wildlife, he has been a mainstay of the technical committees for a number of Mid-Atlantic species, including bluefish, summer flounder, scup, and black sea bass. Dr. Wong has long been recognized for his strong stock assessment skills, spotlighted recently in his development of the catch multiple survey analysis for the horseshoe crab benchmark assessment which was also used in the 2021 Revision of the Adaptive Resource Management Framework for the Delaware Bay.

Jimmy Ruhle & Bobby Ruhle

Father and son Jimmy and Bobby Ruhle have been tireless advocates for the commercial fishing industry, while concurrently advancing cooperative/collaborative approaches to fisheries science. With decades of fishing expertise and knowledge of local fishing grounds, The Ruhles have served on the trawl committees and advisory panels for both the Commission and Mid-Atlantic Fishery Management Council, as well as North Carolina. They are both committed to ensuring the trawl gear used on research surveys promote confidence within the industry. When it became evident that a federal research survey would not be able to sample the nearshore regions, it was Jimmy Ruhle who stepped in to work with state and federal partners to fill the gap and establish the NorthEast Area Monitoring and Assessment Program (NEAMAP) in 2007. NEAMAP has been providing valuable fisheries data ever since and is used in multiple stock assessments.

Atlantic Menhaden/ Ecological Reference Points Team:

**Dr. Amy Schueller,
Dr. Matt Cieri,
Dr. Jason McNamee,
Dr. David Chagaris,
Dr. Andre Buchheister,
Dr. Kristen Anstead,
Dr. Katie Drew,
Sarah Murray,
Max Appelman**

A subset of members from the Atlantic Menhaden/Ecological Reference Points Team were recognized for their successful completion of two concurrently developed Benchmark Stock Assessments for Atlan-

tic Menhaden and Ecological Reference Points (ERP). While these assessments, particularly the ERP assessment, were many years in the making and involved the contributions of dozens of individuals, this group of people have been instrumental in making the ERP assessment a reality. Through their collective work and leadership, this team of state and federal scientists and ASMFC staff helped to significantly advance the understanding of Atlantic menhaden and its role as an important forage fish. Their efforts have provided the Commission with the tools needed to fulfill its promise to stakeholders to manage menhaden in an ecologically sustainable way. Of special note are the efforts of Dr. David Chagaris and Dr. Andre Buchheister, preeminent experts in the field of fisheries resources, predator-prey interactions, and ecosystem-based fisheries management and models, for their work on the development of the ERP model which is currently being used in management.

OUTREACH AND ADVOCACY CONTRIBUTIONS

Greg DiDomenico, Lund's Fisheries

Longtime industry advocate Greg DiDomenico was recognized for his outreach and advocacy contributions to fisheries management along the coast. Previously with Garden State Seafood Association and now with Lund's Fisheries, Mr. DiDomenico has been a tireless voice for New Jersey's commercial fishing industry at the state, interstate, regional and federal levels. He has been an ever present voice at Commission and Mid-Atlantic Fishery Management Council meetings speaking on behalf of the needs of commercial harvesters.

LAW ENFORCEMENT CONTRIBUTIONS

Captain Michael Eastman, New Hampshire Fish and Game Department Law Enforcement Division

Throughout his more than 20 year career, Captain Michael Eastman with New Hampshire Fish and Game Department Law Enforcement Division has proven himself as a very capable leader who cares about the officers he works with and the resources he is charged to protect. He is a longstanding member of the Commission's Law Enforcement Committee, serving as both Vice-chair and Chair to that Committee. He also serves as the law enforcement liaison on several species management boards, including Atlantic herring, northern shrimp, and American eel. His fair and professional approach has earned him the respect of the public he serves. He has led by example and demonstrated for other officers how to become successful through hard work and determination. Captain Eastman's work ethic and level of professionalism have been assets to both New Hampshire Fish and Game and the Commission throughout his career.

Special Agents Chris McCarron & Steven Niemi, NOAA Office of Law Enforcement

The thorough and relentless investigative efforts of NOAA's Special Agents McCarron and Niemi ensured the success of two concurrent prosecutions whose illegal activities undermined the integrity of the Chesapeake Bay blue crab industry. The NOAA Office of Law Enforcement received multiple industry complaints regarding the actions of several companies who were accused of selling imported crab meat as Ches-

apeake Bay Blue Crab. As the Case Agents from the lead agency, Agents Niemi and McCarron coordinated with multiple State and Federal Law Enforcement entities to create and execute the investigative plan. This comprehensive investigation resulted with the companies admitting responsibility for importing over \$8.7 million dollars of foreign crab meat into the U.S. illegally, mislabeled, repacked and marketed the product as Chesapeake Bay Blue Crab. Agents McCarron and Niemi worked tirelessly during their investigations and their work has had a profound and immediate impact on the region's industry.

Enforcement Officer Timothy Wilmarth

Enforcement Officer Timothy Wilmarth is being recognized for his focus and determination in developing a safe and effective enforcement strategy to address the effects of non-compliant offshore, deep set lobster gear on the mortality of the critically endangered North Atlantic right whales and in support of the Commission's American lobster management program. Enforcement Officer Wilmarth took the idea of using remote operated vehicles from concept to reality and has allowed officers to effectively locate and inspect deep set lobster gear without having to physically retrieve the gear, which has historically posed a variety of problems including the safety of officers conducting the inspections. When deployed, the ROV can detect and record any gear or tag violation from the ocean surface down to the ocean floor to include inspecting tags, escape panels, markings, and compliance with trap limits. Through his hard work and technological innovation on the project, law enforcement officers will now have a safer platform to ensure gear compliance and boost efforts to protect endangered species such as the North Atlantic right whale.

WE DELIVER FRESH LOBSTER BAIT

INCLUDING:

HERRING

POGIES

MACKEREL

RED FISH

SKINS

BLUEFISH

CHUM

SALMON
HEADS



FRESH, SALTED, AND QUICK FROZEN BAIT

Barrel Head Bait

WE SELL SALT!

For More Information: To Place An Order:

Mark Flight
mark@barrelheadbait.com

The Bait Line:
857-200-2129
Or Fax:
617-561-8471



Division of Marine Fisheries
 251 Causeway Street, Suite 400
 Boston, MA 02114
www.mass.gov/marinefisheries

**Form DMF-GC
 Gear Conflict or
 Catastrophic Gear Loss Report**

Please complete both sides of this report and return to the above address.

Your Information		
Name:		DMF Permit ID #:
Your Address		
Street:		
City:	State:	Zip Code:
Your Contact Information		
Phone #:		
e-mail address:		
Your Vessel Information		
Vessel Name:	Length: ft	MS/DOC No:
Vessel Homeport:		
Gear Conflict or Catastrophic Loss		
Please be as specific as possible when filling out form.		
Date of Incident:	Time (AM/PM):	
Location (Lat/Lon and/or description of geographic location):		
If other vessel(s) lost gear in the conflict, please list them below (if applicable):		
F/V Name:	MS/Doc #:	Name:
F/V Name:	MS/Doc #:	Name:
Please list the vessel(s) that caused the conflict (if applicable):		
F/V Name:	MS/Doc #:	Name:
F/V Name:	MS/Doc #:	Name:

Description of Event(s). Please include type of gear lost, total amount of gear lost (# of pots, gillnets, etc.) and time lost due to lost gear:			
Type of Gear Lost:			
Amount of Gear Lost:			
Value of Gear Lost(\$):			
Did you contact the Massachusetts Environmental Police or Coast Guard during or after the conflict (Y/N)?			
Witness Information:			
(1) Name:		DMF Permit ID # (if applicable):	
Phone #:		e-mail address:	
Address:	City:	State:	Zip Code:
(2) Name:		DMF Permit ID # (if applicable):	
Phone #:		e-mail address:	
Address:	City:	State:	Zip Code:
Other Comments:			
Your Signature			
Signature:		Date:	

**LEGAL DEFENSE
FUND JUNE 2022**

Brendan Adams

Jeff Bartlett

Joel Bates

Jeff Blackman

Ray Bois

Brooks Trap Mill

Dave Casoni

Eric Lorentzen

Chad Mahoney

Gary Mataronas

James Mataronas

Susan & Jay
Michaud

James Moleti

Bob Nihtila Sr.

Wesley Penney

Therese Sauvageau

Bill Souza

Superior Lobster
and Seafood

Superior Lobster,
LLC

**THANK YOU FOR YOUR
CONTINUED SUPPORT!**



Donate to the MLA Legal Defense Fund to
“Band the Bite” TODAY!

Help us fill the lobster crate and help relieve
the **“PINCH”** of defending commercial lobstermen!

Let’s fill the lobster crate TODAY!

Every \$25 dollars donated puts another lobster in the lobster crate!!

There are several ways to make a donation

MLA website: www.lobstermen.com Legal Defense Fund Donation

Paypal: Legal Defense Fund Donation

Mail or drop off a check:

MLA, 8 Otis Place, Scituate, MA 02066

Call the MLA : 781-545-6984 xt2

Use your camera on your phone to Scan the QR Code

***THANK YOU for YOUR
CONTINUED SUPPORT!***





NEW ENGLAND PROPELLER, INC.

Distributor of Michigan Propellers

Inboard • Outboard

Next Generation 3D Computerized Propeller Analyzer
Computerized Dynamic Balancing



Marine Fuel Tanks

Custom Fabricated & Tested to U.S.C.G Specifications
By Capeway Welding

- Marine Propeller Sales & Repairs - ***4000 Props in Stock***
 - Sierra Engine Parts for All Outboards & IOs
 - CDI Electronics • Camp & Godfrey Zincs
 - NGK Spark Plugs
 - Duramax Cutless Bearings • Spurs Line Cutters
 - PSS Dripless Shaft Seals
 - Buck Algonquin - Struts, Rudders & Stuffing Boxes
 - S/S Shafting • Drive Savers • Globe Impellers



9 Apollo Eleven Rd., Plymouth, MA 02360
Tel: 508-747-6666 800-635-9504 - neprop.com

Massachusetts Lobstermen's Association
8 Otis Place, Scituate, MA 02066
Office 781-545-6984
Fax 781-545-7837
www.lobstermen.com



MEMBERSHIP APPLICATION

TYPE OF MEMBERSHIP Full Voting Associate Business
 \$150 Annual Dues \$150 Annual Dues \$250 Annual Dues

***To qualify for a Full Regular Membership, you MUST (1) hold a valid Mass. Commercial Lobster License, (2) reside in Massachusetts, (3) be sponsored by either two Regular Members or one Delegate, and (4) send in a copy of your lobster license with this application.**

Sponsors:

#1 Name _____ [] Delegate [] Regular Member

#2 Name _____ [] Delegate [] Regular Member

Name _____

Business Name * Business members will now be listed in 2"x2" ad in the new MLA business section at the front of the monthly newspaper, a 2"x2" ad linked to your website will be added to the MLA website, preferential ad location selection in the newspaper and early registration and booth preferences for the MLA Annual Weekend event.

Address _____

City/Town State Zip Code _____

Home Phone Cell Phone Work Phone Fax Number _____

Email Address Website _____

Vessel Name Homeport Permit ID# Type of Permit _____

[] Check here if you would like Hull and P&I Insurance information sent to you

Payment options - Cash, Check, MasterCard or Visa _____

Credit Card Number Exp. Date 3 digit security# Zip Code _____

Signature _____ Date: _____ / _____ / _____

MLA Classifieds

Classified ads are a free benefit to MLA Members and Non-members are a flat \$25.00. Ads run for 5 months & will be automatically deleted unless you call the MLA office to renew.

781-545-6984 or email ads to: tracey.abboud@lobstermen.com

*All ads are subject to review prior to placement

AD #1 (4/22) **FOR SALE- TURN KEY** – Lobster Business- 26' with a 10 1/2 beam flat bottom, 90hp, hydraulic hauler, bilge pump Atkins Lobster Boat, Lobster gear and transferable Area-1 coastal lobster permit. Sold as a package. Serious inquiries only. \$40,000.00 Call or text 781-375-6409 for more information

AD#2 (1/22) **FOR SALE** – 19 2001 Eastern (first year they bought the mold from Seaway); 90 hp Mercury outboard; Hydroslave hauler. Boat custom built. Center console w/canvas top. Center console built more forward creating more deck space for gear/fishing room. Transom built higher. Stainless bow rails, fish finder, depth GPS, washdown pump & Load Rite trailer only a few years old w/power winch. Live tank & culling table. Boat in great shape. \$16,500. 11 coils of new 5/16 sinking rope. \$2.25 lb. Coils-1800 & vary from 40-44 pounds. One coil 5/16 floating line \$2.00 lb. Serious inquiries only. Jack @ 5 p.m. 508-747-5680

AD#3 (6/22) **FOR SALE** – Hydraulic Components, parts and service. Pumps, Motors, Valves and Accessories. Hydraulic Hoses made while you wait. Great Prices–Same day service (in many cases)-Wide selection of in-stock items. Rebuilt items occasionally available. ROSE MARINE, Gloucester, MA 877-283-3334

AD#4 (4/22) **FOR SALE** - Fresh Lobster Bait-Fresh pogies, gillnetted/cast netted on the F/V Bug Catcher II-iced & lightly salted top quality lobster & fish bait. .60 cents per pd. Free local delivery in Connecticut. Call/Text DJ or Kory 203-824-8247

AD#5 (4/22) **FOR SALE** – 24 Crosley net lift \$2,000.00 11 roller \$600.00 needs some work. 10 rehung foam core 6 1/2 x 25 x 14 BRO offer 22 rehung foam core 7x25x16 All 65 lb. lead line BRO Text Only 617-694-4802

AD#6 (3/22) **LOOKING TO BUY** - MA coastal lobster permit-David @781-775-5569

AD#7 (1/22) **Looking to buy used rope** – located in Sandwich MA-will pick up on Cape Cod & South Shore. E-mail lobstermats@gmail.com or 617-275-3744

AD#8 (2/22) **FOR SALE** – Twin Disc MG506 1A 1.54:1 ratio running takeout, spun tested. \$3000 Steve 978-257 1062

AD#9 (12/21) **ATTENTION C-TRAP CUSTOMERS/GOT WOOD** – New wooden conch traps for sale, many types, prices starting @ \$23.50ea for 20x20 all oak frames 3 wide pine lath sides. Will cut custom lobster traps/frames/runners/laths. 508-989-4762

AD#10 (6/22) **FOR SALE** - 1966 Cedar over Oak 34 wooden lobster boat. NE Ford Leaman 135 HP engine, re-built tranny, Stainless shaft, 4 blade prop. Built by Ano Day -Stonington Maine. Several upgrades throughout ownership of boat. In process of building a new boat-this boat was fished last season. \$7,500.00 or B.R.O. Call Dean @ 781-264-7501

AD#11 (5/22) **FOR SALE** - Warp–Used & some new, mostly knot free. 76 lbs. 5/16, 33 lbs. 3/18 \$99 takes all 508-269-1406 Plymouth

AD#12 (5/21) **FOR SALE** - 18 Wooden Lapstreak Skiff. In remarkable condition. Bottom was fiber-glassed before first used. All heavy duty oak ribs, stiffeners, ribs and floor cleats. Excellent boat for coastal/harbor fishing, or for lugging traps. Will send picture upon request. \$1990.00 or BRO. Call 508 269-1406.

AD#13 (1/22) **FOR SALE** - Bronze dual ram steering Quadrant-Freeman Oval hatch- 15x23 opening+ SS longline rail roller- and SS crucifier. SS mast base. 2 2ft., outriggers-no base-PC Winplot complete chart plotting program w/ monitor, computer, Furuno GPS and all support items needed. Mike 978-745-6182 leave message

AD#14 (5/22) **FOR SALE** – 300 3 – Cement runners \$5.00 each Call 631-286-3335

AD#15 (12/21) **FOR SALE** – Cab for pickup truck w/ 8 ft bed. No damage, Black w/ windows. \$50.00 B.O. Phil 617-429-2956

AD#16 (2/22) **FOR SALE** – Gillnet gear, 24 Crosley lifter, all hardware to mount, picking table /spreader \$900.00 6 insulated vats \$50.00 ea. 8 pingers \$30.00 ea. 40 round-fish nets, 40 monk fish & 11 new webs all \$45.00 ea. Call/text 774-264-0083

AD#17 (6/22) **HELP WANTED** – Lobster Boat located in Marshfield is looking for help for the 2022 fishing season. Experienced preferred but will train. No drama, no drugs & must have own transportation. Call 781-767-4130/508-510-7792

AD#18 (6/22) **FOR SALE** – 24' Privateer, 5.7L Crusader low hours, Honda hydraulic power pack with 10" hauler. S.S. Davit. Plotter, sounder, radar, VHF. New cockpit floor & deck with 2' stern extension. Rigged for pot hauling. Ready to fish. \$16,000. Area 2 coastal Mass lobster permit, 90 pot allocation \$25,000. Selling as a package, boat & permit \$35,000. Located in Oak Bluffs. Call-774-563-0393

AD#19 (6/22) **FOR SALE** - 1980 Bob Rich 40 wooden lobster boat. 471 Detroit diesel, twin disc gear, hydro-slave pot hauler w/ diverter valve for other fisheries. Two 75 gal fuel tanks (fiberglass) under deck, full cabin, GPS, Koden depth sounder, VHF radio, MA coastal Area 1 lobster permit, 800 trap. Federal Area 1 lobster permit w/ endorsements (groundfish/dogfish) 800 pot limit. 150 wire lobster traps, some never used (brand new) 60-70 buoy's, extra ropes, safety equipment, sea anchor, 12 fiberglass skiff, misc; lobster related equipment, spare propeller (never used) trap related repair equipment. \$70,000.00 firm needs to go as a package. Call Bill @ 781-834-7418

AD#20 (6/22) **FOR SALE** - 1,000 hooks new tub trawl-gear W/anchors, 180 buoy lines. B.R.O. Bryan @ 508-221-8568

AD#21 (6/22) **FOR SALE** - 1987 Daniels Head 39' 11" Fiberglass Gillnet boat. 207HP Mitsubishi D14.14 T Diesel engine (1992), Twin Disc 506 trans, complete electronics, 2 berth, 6'x5' aluminum gill net reel with stainless frame, 2 fish holds, 2 insulated deck boxes, rollers, 2 bus heaters, vessel in good condition – new fuel tank, new paint/fiberglass/fish boxes (2022). \$79,500 or B.R.O. Fed Permit Monkfish B with around 80 nets and 16 dog nets with buoy st anchors \$45,000. Federal directed shark permit \$15,000. Call 609-294-1628 /text for pictures 609-713-5228

AD#22 (12/21) **FOR SALE** - 34 J. Ervin Jones 1978, 1 Mahogany on Oak (re-fast 2004) 3208TA CAT 507 twin disc direct

drive clutch, spare prop Furuno 1623 Radar Furuno FVC 620 Sounder Furuno, GPS 32 standard horizon chart plotter, ICOM VHF. 14 skiff w/outboard, clip gun cutting tool. \$15,000.00 Call Les before 8p.m. 508-364-6926

AD#23 (1/22) **FOR SALE** - The NOVE-purchased from original owner in Portland ME & currently owned by (2nd owner) past 3 years & has grown to be a great part of our family-year-round. Nove very versatile & comfortable. Excellent for cruising & uses little fuel, has hauler & davit for lobstering, multiple rod holders for fishing. The aft deck can seat 4-6 Adirondack chairs comfortably, main cabin-dining table-seats 4 comfortably & converts to a bed-sleeps 2. Fore cabin has exceptionally large v-berth could be compared w/a king-size bed. The Portside-full-size storage closet, head, shower & sinks w/ mirror, etc. The Starboard side- expansive cabinets w/ sink, microwave & bar. Wooden hull (Pine planks over white Oak frame) Dry weight 17,000 lbs, Teak trim, fiberglass deck & house, Hydraulic steering, 2 100-gal; water tanks, 2 100-gal; fuel tanks, Fore Cabin head/bed/sink/microwave/ storage, Keel cooler setup for Engine, Autopilot-ITEMS REPLACED-2018, Cummins Diesel Engine -6 cylinder 6BT T1 M@2600rpm R KC (100 hours) Rebuilt transmission (2019) propeller, exhaust. \$39,500 Brandon-978-465-3022

AD#24 (2/22) **FOR SALE** - LMA-1 Federal lobster permit, 800 trap allocation, good history \$38,000.00 978-578-8882

AD#25 (3/22) **LOOKING FOR** - Area 1 coastal lobster permit. 339-788-3621

AD#26 (3/22) **FOR SALE** - 1986 38ft Atkinson 671 Detroit- runs great- 2 shaft 507 T.D. 12 standard horizon chart plotter-8 Sitex chart plotter brand new. Brand new clutch master pump -14 hauler -120-gallon fiber glass gas tank. Area 1 in-shore lobster permit-\$55,000.00 Call/ Text 508-577-4868

AD#27 (3/22) **FOR SALE** - 95 traps 4 x 15 x 22 1/2 tops/heads/supports/all openings cut/vents \$90.00 each Call 781-424-1670

CAT MARINE ENGINES

Tier 3 Commercial Line-up

C7.1



C7.1 Tier 3 Commercial Ratings:

280 HP @ 2300 Heavy Duty "B" **IN STOCK**
350 HP @ 2500 Maximum Continuous Duty "C" **IN STOCK**
400 HP @ 2600 Intermittent Duty "D" **IN STOCK**
425 HP @ 2700 Intermittent Duty "D" **IN STOCK**

C9.3



C9.3 Tier 3 Commercial Ratings:

375 HP @ 1800 Heavy Duty "B"
416 HP @ 2100 Maximum Continuous Duty "C"
476 HP @ 2300 Intermittent Duty "D"

C18



C18 Tier 3 Commercial Ratings:

470 HP @ 1800 Continuous Duty "A"
600 HP @ 1800 Continuous Duty "A"
670 HP @ 1800-2100 Heavy Duty "B"
715 HP @ 1800-2100 Maximum Continuous Duty "C"
803 HP @ 2100 Intermittent Duty "D"

* Tier 4 Exempt Light Commercial Ratings:

1,001 BHP @ 2300
1,136 BHP @ 2300

C32



C32 Tier 3 Commercial Ratings:

750 BHP @ 1600-1800
800 BHP @ 1600-1800

AUTHORIZED MARINE DEALERS

Billings Diesel & Marine Service

Stonington, ME

Dennis' Welding & Marine

Beals, ME

Front Street Shipyard

Belfast, ME

Lyman Morse at Wafarer Marine Corporation

Camden, ME

Journey's End

Rockland, ME

Fairhaven Shipyard & Marina, Inc.

Fairhaven, MA

Guy Crudele Repair

Gloucester, MA

Sacchetti Marine and Industrial LLC

Plymouth, MA

Windward Power Systems

Fairhaven, MA

DePaul Diesel Services, Inc.

Portsmouth, RI

Hinckley Yacht Service

Portsmouth, RI

Rhode Island Engine Company, Inc.

Narragansett, RI

*All T4 Exempt Light Commercial Ratings, require qualifications review and approval by CAT Factory.

*Contact Nick Fawle or Your Authorized Marine Dealer for Tier 4 exemption qualification details.

For Marine Engine Sales, contact Nick Fawle, our new Marine Market Manager.

Nick Fawle at 603-484-5248

Nick_Fawle@miltoncat.com

Milton



miltoncat.com

Massachusetts Lobstermen's Association
8 Otis Place
Scituate, MA 02066

PRSR STD
U.S. POSTAGE
PAID
Permit 137
New England Newspapers, Inc.



**Stock and Custom-Built Traps
Lobster and Specialty Traps
Aquaculture Supplies
Huge Inventory of Commercial
Fishing Supplies
Four Locations in Maine**



**BROOKSTRAPMILL.COM
(800) 426-4526**