



MASSACHUSETTS LOBSTERMEN'S ASSOCIATION



JOIN TODAY and
show your support

A LEADING Commercial Fishing Industry Association in New England

MARCH 2022 NEWSPAPER • WWW.LOBSTERMEN.COM

Help halt Holtec from dumping 1 million gallons of radioactive water into Cape Cod Bay

Over the last several months, the MLA has been deeply involved with the Cape Downwinders to halt Holtec from dumping 1 million gallons of radioactive water from the Pilgrim nuclear power plant into Cape Cod Bay. In today's world of cleaning up the oceans one would think this would not be happening, unfortunately it is happening right here in the ocean we all depend upon being pristine.

Recently, the MLA sent a letter to respectfully SUPPORT the Emergency Bill H.4444 - An Act relative to preventing the discharge of radioactive materials. [No person shall directly or indirectly deposit, dispose of, or discharge, any solid or liquid radioactive material directly or indirectly (i) in any coastal or inland waters as defined in section 1 of Chapter 131, (ii) within the rise and fall of the tide waters, or (iii) on any land owned by any other person.]

In 2020, the 872 commercial lobstermen here in the Commonwealth landed over 16 million pounds of lobster, with an economic value of 274 million dollars to the local economy. Without a clean and healthy ecosystem there would be no commercial lobster fishing industry here that provides a sustainable, healthy and clean protein to consumers. By allowing Holtec to dump ANY radioactive water into our pristine ecosystem is

DUMPING, Page 23

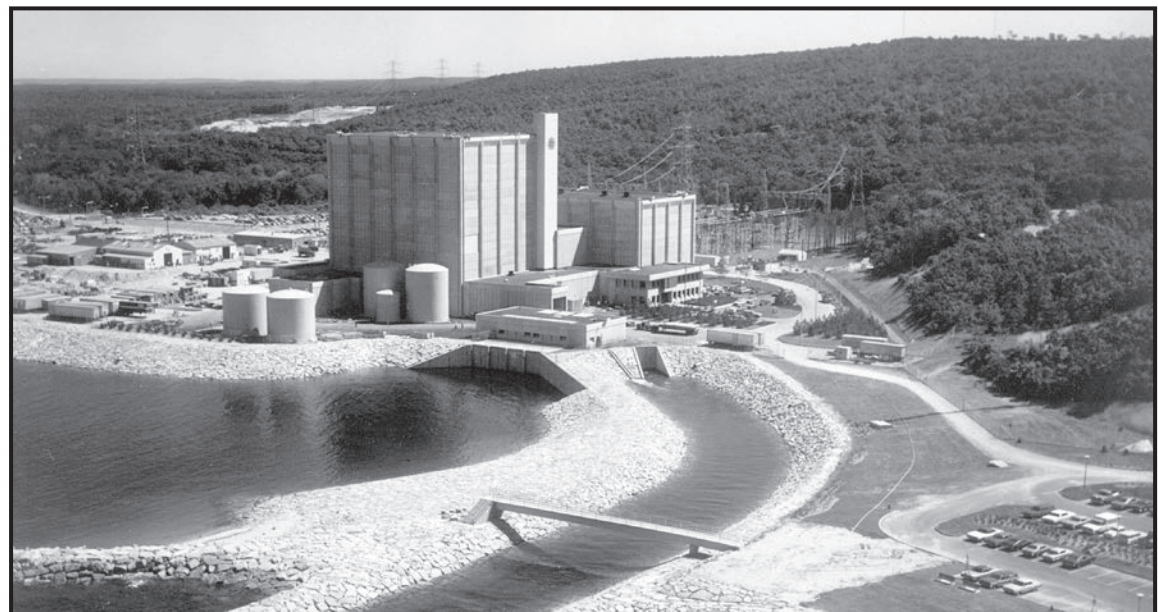

Above: Boston Edison Company's Pilgrim Station Unit 1 at Plymouth, MA, circa 1972.

Source: Wikimedia Commons, Energy.gov

Right: A protest sign seen at recent rallies in an effort to stop Holtec International (who bought the decommissioned facility in 2019) from disposing the site's radioactive materials into Cape Cod Bay.





SERIOUS ABOUT SAFETY

LRSE.COM | 401-816-5400

590 FISH RD, TIVERTON, RI 02878
 181 OLD COLONY AVE, UNIT A, BOSTON, MA 02127
 55 STATE ST, NARRAGANSETT, RI 02882



SALES • SERVICE • TRAINING • RENTAL • OUTFITTING • PICKUP + DELIVERY

Safety Equipment Servicing

Life Raft + Survival Equipment has been selling and servicing all major brands of Life Rafts, EPIRBs/PLBs, Life Jackets, Immersion Suits, and Man Overboard Equipment since 1983.

We offer pickup and delivery to over 20 locations throughout the Northeast.

CALL FOR GREAT PRICING.

North East Safety Training

NEST, a division of LRSE, offers hands-on Basic, Advanced, and Customized Safety Training Courses, Monthly Drill Conducting, First Aid/CPR/AED Courses and Vessel Inspections.

VISIT OUR WEBSITE TO LEARN MORE.

-  LIFE RAFTS
-  EPIRBs + PLBs
-  LIFE JACKETS
-  IMMERSION SUITS
-  MAN OVERBOARD
-  PICKUP + DELIVERY

COMMERCIAL LIFE RAFTS

Elliot, Zodiac, Crewsaver, Revere, Viking



FIBRELIGHT LADDERS

Man Overboard Recovery Cradle, Self Recovery Ladder



IMMERSION SUITS

Imperial



EPIRBs

ACR V4



FIRETKO®

Fire Suppression Tool



LIFE JACKETS

Mustang



MLA Sponsors

The following companies are proud supporting MLA members.

We encourage our members to patronize them. If your company is not listed and you would like it to be, contact Tracey Abboud at 781-545-6984, ext. 2

ALIVE & KICKING LOBSTER

LOUIS MASTRANGELO
CAMBRIDGE, MA
617.876.0451

ALUMATECH MARINE

ANDY COSTA
PLYMOUTH, MA
508.746.7774

BAR HARBOR LOBSTER

JEFF HAZELL
ORLANDO, FL
407.851.4001

BOSTON LOBSTER

NEIL ZARELLA
617.464.1500
bostonlobstercompany.com

BOSTON SWORD & TUNA

STEPHEN SCOLA
BOSTON, MA
617.946.9850

BROOKS TRAP MILL

STEPHEN BROOKS
THOMASTON, ME
207.354.8763
stephen@brookstrapmill.com

CAPE ANN MARINE

SALES & SERVICE
978.283.0806
CapeAnnMarina.com

C-TRAP

MATT BORGES
MATTAPOISETT, MA
508.758.2740

CAPE CODDER MARINE, LLC

BOB DOBIAS
SWAMPSCOTT, MA
978.979.1795
capecodderboats.com

CAPE SEAFOODS BAIT DEALER

GERRY O'NEIL
GLOUCESTER, MA
978.479.4642

CAPE FISHERMEN SUPPLY

DAVE LIBBY
CHATHAM, MA
508.945.3501

CAPE TIP SEAFOODS

CHRIS KING
PROVINCETOWN/ORLEANS
508.487.0259 | 508.225.7221

CAPTAIN MARDEN'S SEAFOODS

KIM MARDEN
WELLESLEY, MA
781.329.7007 | 781.329.0792
captainmardens.com

CHERRY ST. FISH MARKET

DARRYL PARKER
DANVERS, MA
978.777.3449

CHRIS ELECTRONICS CORP.

FAIRHAVEN, MA
508.994.8257

COASTAL HYDRAULICS

RICH TUCKER
SEABROOK, NH
603.474.1914
coastalhyd.com
sales@coastalhyd.com

COHASETT LOBSTER POUND

TOMMY ALIOTO
COHASETT, MA
781.383.1551

EAST COAST SEAFOOD

SPIROS TOURKAKIS
LYNN, MA
781.593.1737

ELECTRA-DYNE CO INC.

JUDY MACCAFERRI
PLYMOUTH, MA
508.746.3270

FARM CREDIT EAST

MIDDLEBORO, MA
508.946.4455

FISHER AIR FASTENERS

ED & CHRIS FISHER
PEMBROKE, MA
781.826.2522

FISHERMEN SERVICES

DONNA CHEPREN
781.545.5073
fishermenservices.com

FLEET PROPELLER SERVICE

MIKE VALM
FAIRHAVEN, MA
508.979.8000

FRIENDSHIP TRAP CO.

JERRY WADSWORTH
FRIENDSHIP, ME
800.451.1200

HAMILTON MARINE INC.

56 US ROUTE 1 BYPASS
KITTERY, ME 03904
207.439.1133
hamiltonmarine.com

HARBOR FUELS

info@harborfuels.com
617.720.3835

HERCULES

JOHN REARDON
NEW BEDFORD, MA
508.993.0010

HOLBROOK & MURPHY

SAM BLATCHLEY
BOSTON, MA 02110
617.428.1151 EXT.23
www.holbrookmurphy.com

JAMES HOOK & CO.

ED HOOK JR.
BOSTON, MA
617.423.5500

JOHN M. KARBOTT CUSTOM

WOODEN BOAT
BUILDING & REPAIR
PLYMOUTH, MA
508.224.3709
by-the-sea.com/
karbottboatbuilding

JOLIN LOBSTER

MANCHESTER, MA
978.526.7954

KETCHAM TRAPS

HEATHER KETCHAM
NEW BEDFORD, MA
508.997.4787

KINGFISHER TRAP

CARL HOWARD
DENNIS, MA
508.385.5968

KING LOBSTERS

D.J. KING
BRANFORD, CT
203.488.6926

KING MARINE LLC

CAPT. GEORDIE KING
MARINE SURVEYOR
207.337.8706
kinggeordie@comcast.net

LOBSTER CRUISES

PAUL QUINTAL
PLYMOUTH, MA
508.746.5342

LOBSTER TRAP FISH MARKET

MONUMET BEACH, MA
508.759.6400
lobstertrap.com

LOBSTER TRAP CO.

LOGAN CLARK
BOURNE, MA
508.759.4928
lobstertrap.com

LYNCH LOBSTER CO.

JOHN LYNCH
BEVERLY, MA
978.921.8088

MAIN STREET WIRE

PETER CHRISTIAN
DOUGLAS, MA
508.847.8888

MARINE HYDRAULIC ENGINEERING

ROBERT CROWE
ROCKLAND, ME
207.594.9525 | 800.747.7550

MILTON CAT POWER SYSTEMS

KEVIN HAMPSON
MILFORD, MA
508.207.8542

MORTILLARO LOBSTER, INC.

VINCE MORTILLARO
GLOUCESTER, MA
798.281.0959

NAHANT FISH & LOBSTER

781.592.7500

NAVROC MARINE ELECTRONICS

JASON PHILBROOK
ROCKLAND, ME
207.596.7803

N.E. MARINE & INDUSTRIAL INC.

MIKE RICHARDSON (NH)
603.436.2836 | 781.834.9301
Info@newenglandmarine.com

NEW ENGLAND PROPELLER

RON PECK
PLYMOUTH, MA
800.635.9504
neprop@aol.com

NORTH ATLANTIC POWER-TWIN DISC

SAM PROFIO
EXETER, NH
sprofio@glpower.com |
603.418.0470

PIGEON COVE COOP

ROBERT MORRIS
978.479.3828

RFP LOBSTER BAIT

DICK PERENTZ
774.248.0292

RIVERDALE MILLS

NORTHBRIDGE, MA
508.234.8715

ROSES MARINE

MARTY BOLCOMBE
GLOUCESTER, MA
877.283.3334
rosesmarine.com

SEA CLIFF LOBSTER

FRANK COLLINS
MANOMET, MA
508.224.5700

SPURS MARINE MFG.

PABLO SOSA
FORT LAUDERDALE, FL
800.824.5372

SUPERIOR LOBSTER

MARSHFIELD-SANDWICH
774.773.5048
www.superiorlobster.com

THE NEW RESULT

LOUIS LARSEN
Mvseafood@vineyard.net

TWO COUSINS FISH MARKET

BRIAN O'DONOHUE
FREEPORT, NY
516.379.5065

WELLFLEET SHELLFISH CO.

508.255.5300
sales@wellfleetshell.com

WINDWARD POWER SYSTEMS

FAIRHAVEN, MA
774.992.0059
windwardpower.com

WOOD'S SEAFOOD

JAY KIMBALL
PLYMOUTH, MA
508.746.0261
www.woodseafood.com

YANKEE FISHERMEN'S CO-OP.

SEABROOK, NH
603.474.9850



Published by the Massachusetts Lobstermen's Association, Inc.
8 Otis Place, Scituate, MA 02066

– Published monthly –

Mailed to all paid members of the Massachusetts Lobstermen's Association

Newsletter Departments

Editor, Industry News, Notice Section, Editorial, Blog, Industry News, Promotions, Layout, Advertising:

Beth Casoni – Executive Director

Buy Sell Swap: *Tracey Abboud*

Newsletter Advertising Rates

The MLA Newsletter is published monthly (Please note that all pre-paid ads for last year will be honored)

\$50 – ¼ Page Ad

\$80 – ½ Page Ad

\$110 – Full Page Ad

Color Ads – + \$50 per ad

The Massachusetts Lobstermen's Association would like to welcome the following new members to the Association. Your Association will continue its efforts on your behalf to conserve the resource, protect your livelihood, keep you informed, promote the industry and provide you with increasing benefits as they are developed. MLA stands ready to help you in anyway, at anytime – just let us know how!
 Safe on the water and good fishing!

NEW MLA MEMBERS:

TYLER BENTON

F/V No Regrets • Provincetown

DAVID DAUPHINEE

F/V Island Girl • Scituate

JOHN GREENLEAF

F/V David & Jenna • Gloucester

TYLER HAGENSTEIN

F/V No Name • Barnstable

JAMES SJOLUND

F/V Julie Alice • Nantucket

CHUCK SOLAN

F/V Riddler • Point Pleasant, N.J.

EDWARD WIESSMEYER

F/V Laura Jean II • Hull

Make cleanup easy and fast.

Blast Away!
 Onboard Pressure Washers
 5.6 GPM @ 3,500 PSI

Our pressure washers come with everything you need, including 50' hose and wand with turbo nozzle.



Belt Driven

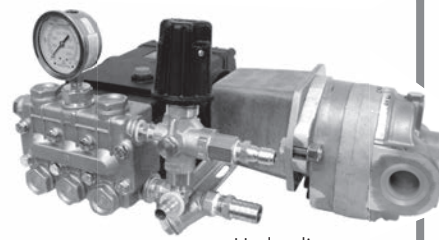

Hydraulic

Salt or Fresh Water



603-474-1914 • sales@coastalhyd.com

www.coastalhyd.com

28 Route 286, Seabrook, NH



THE Specialists
 FROM BUOY TO TRAP

**Built the Best, Built to Last,
 Built Your Way.**

**PROVEN PERFORMERS!
 Rockbottom Runners**



Our precision formulation and process has been refined over the years to provide the optimum balance of strength and flexibility... – and the wise test shows it

Over **20 YEARS** of fishing;

Well over **HALF A MILLION** sold



Could you do this with any other concrete runner?



SOLID STEEL CORE - TOUGH POLYMER COATING



Over **6 YEARS** of fishing.

Over a **QUARTER MILLION** sold



OCEAN-TESTED for years... aircraft carrier decking and pilings in the marine borer intense Panama Canal Zone.



The toughest species of junglewood we've found ... and the only kind we sell.

**We are constantly listening to our customers:
 Your feedback + continuous improvement = proven reliability**

Here to serve you!

Jerry Wadsworth (207) 542-0842 jerryw@friendshiptrap.com

Jimmy Emerson (207) 483-6555 jemerson@friendshiptrap.com

Mike Wadsworth (207) 542-0841 mikew@friendshiptrap.com

Friendship Office: (800) 451-1200; (207) 354-2545

Columbia Falls Office: (800) 339-6558

Visit our website: www.friendshiptrap.com



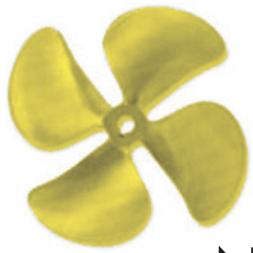

NEW ENGLAND PROPELLER, INC.

Distributor of Michigan Propellers

Inboard • Outboard

Next Generation 3D Computerized Propeller Analyzer
Computerized Dynamic Balancing



Marine Fuel Tanks

Custom Fabricated & Tested to U.S.C.G Specifications
By Capeway Welding

- Marine Propeller Sales & Repairs - ***4000 Props in Stock***
 - Sierra Engine Parts for All Outboards & IOs
 - CDI Electronics • Camp & Godfrey Zincs
 - NGK Spark Plugs
 - Duramax Cutless Bearings • Spurs Line Cutters
 - PSS Dripleless Shaft Seals
 - Buck Algonquin - Struts, Rudders & Stuffing Boxes
 - S/S Shafting • Drive Savers • Globe Impellers



9 Apollo Eleven Rd., Plymouth, MA 02360

Tel: 508-747-6666 800-635-9504 - neprop.com



Service Provider for MLA Non-Profit Boat Protection Cooperative Ltd.

MLA's #1 Commercial Boating Insurance Provider

Agreed Hull Value – Protection & Indemnity

Crew Coverage - Extended Policy Limits - Chartering

Marina Floaters - Multiple Fisheries - Deductibles

Call now for a free quote 781-545-5073

or

Request a quote online at fishermenservices.com



As the HAULER TURNS

After a blustery couple of months, I know I am looking forward to some spring like days in March along with a little Irish luck we will have them. Boy, do we need some Irish luck to get through the ongoing right whale litigation the MLA is embroiled in. There may just be a golden ticket at the end of it all in the form of the Incidental Take Permit (ITP).

As you all are well aware, the ITP process is ongoing and will take the better half of this year for the MA Division of Marine Fisheries (DMF) to complete the application to National Marine Fisheries Service (NMFS). Overall, the ITP application will have taken the DMF better part of two years to complete and will take NMFS an additional two years to review.

The ITP process is not a swift process as everything you have been asked to do to reduce risk and what the DMF has indicated they will do to certify enforcement will be scrutinized with a microscope. The rules to reduce risk are only as good as the ability to enforce them along with documented compliance.

If you have not been hearing the dock talk over the last couple of months, here is some food for thought. The State and EPOs have been actively removing derelict gear along with non-compliant gear out of the closed areas within state waters. There have been hundred's of lost or derelict gear removed from the closed waters along with hundreds of non-compliant gear.

There were also some harbors that were frozen in and a few individuals had extenuating circumstances that they could not get all of their gear out before the February 1st closure date. The MLA was in communication with these fishermen, the DMF and EPOs to keep everyone informed on the progress that was being made to remove the gear in a timely manner.

While some fishermen thought these individuals got a PASS, they did not get a PASS and their gear was removed. No one is getting a PASS or a get out of Jail Free card when it comes to right whale violations.

If anyone is debating about being non-compliant with

the right whale regulations, I strongly encourage you to think again. The State is NOT going to tolerate ANY non-compliance. The entire lobster industry is hanging in the balance of the DMF's ability to show that they are checking and enforcing all the risk reduction measures. Now, more than ever there is no room for error.

After having spoken to many of you over the last several months and having listened to your frustration on all the gear marking rule changes, you're frustrated, you're not the problem, you're only fishing in 50' of water and so on, please remember that there are only two signatures on your permit; yours and the DMF Directors. If there is anything that I can stress now is NOT, the time to be non-compliant.

The DMF understands all of the frustration the industry is going through and they have ordered a slew of gear marking supplies and have over 1300 coils of weak rope that they will be distributing to the industry to help offset any costs incurred. The MLA will be one of the pick-up sites



and we will keep you posted on when we will be holding this pickup in March-April.

If anyone has any questions on any of the right whale regulations please call me 781-545-6984 xt.1 or email me beth.casoni@lobstermen.com because at the end of the day your actions or inactions will have an impact on the entire industry as the DMF applies and the State awaits the results on the ITP application in 2024.

Safe on the water,

Beth Casoni

Director

FISHING PARTNERSHIP



SUPPORT SERVICES

Mission

To improve the health, safety and economic security of commercial fishermen and their families.

Spring Schedule 2022

Safety Training Classes

March 3	Safety & Survival	New Bedford, MA	Morgan	774-840-9419
March 4	Drill Conductor	New Bedford, MA	Morgan	774-840-9419
March 22	Safety & Survival	Newport News, VA	Morgan	774-840-9419
March 23	Drill Conductor	Newport News, VA	Morgan	774-840-9419
March 24	Safety & Survival	Reedville, VA	Morgan	774-840-9419
March 25	Drill Conductor	Reedville, VA	Morgan	774-840-9419
April 7	Safety & Survival	Provincetown, MA	Julia	774-840-9418
April 8	Drill Conductor	Provincetown, MA	Julia	774-840-9418
April 21	Safety & Survival	Montauk, NY	Nina	978-865-2018
April 22	Drill Conductor	Montauk, NY	Nina	978-865-2018
May 19	Safety & Survival	Gloucester, MA	Maria	978-865-2017
May 20	Drill Conductor	Gloucester, MA	Maria	978-865-2017

Check out our website calendar for updates on all safety training classes. Fishing Partnership will be offering more classes this Spring, including in May in the state of Maine.

Fishing Partnership Offers Free Health Insurance Support, Year-Round

Fishing Partnership Navigators are certified community health workers who can assist MA residents with applying for health insurance, updating income, and finding a primary care physician. You may be eligible to enroll in health insurance anytime during the year. Reach out to a Navigator today to explore all your options.

NAVIGATOR OFFICES:

Gloucester
978-282-4847

New Bedford
508-991-3043

Plymouth
508-746-5400

Chatham
774-840-9393

Massachusetts maintains a mandate for all individuals to have health insurance. Unenrolled residents could pay a tax penalty. Don't risk it - call a Navigator and get covered today!

Scan to View
Calendar of Classes



617-928-3443
fishingpartnership.org



Follow



Visit MAHEALTHCONNECTOR.ORG
to enroll directly



Stellwagen Sanctuary Advisory Council discusses ropeless gear, manage plan, sand mining & whales

The Stellwagen Sanctuary Advisory Council (SAC) held its 64th meeting on February 16th, 2022. Again, this was a zoom meeting.

There was yet another discussion on having the Sanctuary establish a working group to look at rope-less fishing gear. A motion was made to establish such a group. This was another attempt regarding whale safety.???

Eric Meschino, Bill's alternate, was present and noted that the current weak rope and buoy breakaways are working and further discussions on buoy-less lobster gear is not needed. Bill Adler went into detail as to why the whole idea is not practical, is already being looked at by the state and federal agencies, is costly, raises concern about gear conflicts and will not be accepted by fixed gear fishermen. He reiterated his opposition not only to forming a working group but even having the Sanctuary spend time and money looking at a ridiculous idea when fishermen are already doing everything they can to prevent an interaction with Whales.

Several other SAC members and state and federal representatives also voiced reluctance to support the idea. In a roll call vote, the motion failed.

The Sanctuary then moved on to a review and update on the draft Management Plan. Comments heard or received from the public hearings were then presented. There were over a hundred comments heard or letters received on the Plan document. These ranged from prohibit fishing, more protection for forage and spawning fish, more protec-

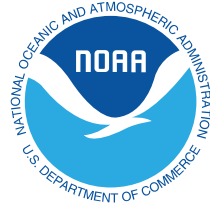

NATIONAL MARINE
SANCTUARIES
GERRY E. STUDDS
STELLWAGEN BANK



tion for marine mammals, speed restrictions, opposing mooring buoys over shipwrecks, protection for seabirds, water quality issues, more education and outreach, habitat concerns and the Sanctuary's budget.

This was followed by a review of the Sanctuary's Work Plan. Among the listed issues were the, Shipwreck Avoidance Program, (Maritime Heritage issue), protection for the Right Whales from fishing gear and relationships with the shipping interests. This whole issue was listed as a medium priority! There were other issues on the on the Work Plan.

Dr. Dave Wiley, (NOAA Research Scientist) gave several presentations during the meeting. Back on the rope-less gear discussions, he noted many problems regarding popup buoys, costs, gear conflicts, and an idea of having fishermen sending a ROV that would go down and pull up the traps, having a transponder on the traps??! **NOT** He also was working on having an experimental area in the Sanctuary where one could monitor whale density and gear density and where entanglements could occur!??

Another presentation by Dave, focused on sand mining for beach nourishment. He noted there were many problems with this idea, which included how it could disturb marine life such as,

whales, sand lance, (a forage species) scallop habitat, birds and even herring. He gave a detailed report on the importance of the sand lance species.

Sanctuary staff reported on events, exhibits, articles and celebrations planned to mark the National Sanctuaries System's 50th year. Stellwagen by the way, will be celebrating its 30th year.

It was noted during several of the discussions that NMFS is considering moving the "derby style" scallop fishery on the bank from April to May. A problem here is that in May, lobster fishing starts up. Dave Wiley noted that there is usually not much gear in the scallop area at that time??!

In the Agency/Governmental reports on the agenda, Coastal Zone Management (CZM) reported that it was involved in the Wind Farm issues everywhere. The Division of Marine Fisheries, (DMF) noted that in April there is expected to be a final rule released on the Whale Rules and it was also working on the Herring issues.

The Enforcement Report was given by the USCG and NOAA enforcement representatives. The Coast Guard mentioned it was working on enforcement of vessel speed limits and that it had several new 154' vessels. NOAA enforcement (OLE) indicated that it had no violations in the Sanctuary and will be working

on lobster fishery issues, Whale Take Reduction issues and any harassment events (whales!).

The Federal Fishery's Council report focused on various groundfish and scallop plans and the NOAA representative will be working on survey's, speed reductions and whale protection.

On other agenda items, the Sanctuary reported on the usual budget, SAC elections and business issues.

Among other comments from the SAC members at the end of the meeting, Bill Adler brought up the proposed discharge of the Radioactive Waste in Cape Cod Bay. It has been proposed by the company dismantling the Plymouth Nuclear Power Plant to dump the radioactive water into the Bay. Bill asked if the Sanctuary and the state's CZM were involved in opposing this action. He cited obvious concerns that, as he indicated, we are all worried about, Whale issues, water quality, water temperature, acidification, habitat and fishing issues, what about dumping contaminated water?! Huh?!

Both the Stellwagen Superintendent, Pete DeCola and CZM's Todd Callaghan indicated that they were now fully involved in the issue. Center for Coastal Studies (CCS) Rich Delaney, chimed in indicating that his organization in P-town is also involved in opposing this proposal. In other words, they're on it. Bill said "good", keep on it!!

The 4- hour meeting adjourned at 1 p.m.

Bill Adler
Fixed Gear Commercial SAC Member



The Commonwealth of Massachusetts Division of Marine Fisheries

251 Causeway Street, Suite 400, Boston, MA 02114

p: (617) 626-1520 | f: (617) 626-1509

www.mass.gov/marinefisheries



CHARLES D. BAKER
Governor

KARYN E. POLITO
Lt. Governor

KATHLEEN A. THEOHARIDES
Secretary

RONALD S. AMIDON
Commissioner

DANIEL J. MCKIERNAN
Director

Buoy Line Marking Rules for Trap Fisheries in 2022

TERMS

- **Buoy Line** means the line that extends through the water column from the buoy at the surface to a single trap on the ocean floor or to a groundline that connects multiple traps in a trawl and extends no more than 12' from the first trap in the trawl.

- **Surface System** means that portion of the buoy line comprised of the first 12' extending down through the water column from the buoy at the surface.

- **Body of the Buoy Line** means that portion of the buoy line extending up the water column from the trap or groundline to the surface system.

- **Solid Mark** means marks within the buoy line that are continuous and not containing gaps or spaces, such as tape, paint, or an insert of an appropriately colored line.

- **Non-Solid Mark** means marks within the buoy line that are not continuous, such as tracers.

- **Weak Line Contrivance** means a device installed into the buoy line that is designed to part when exposed to 1,700 pounds of tension or less.

BUOY LINE MARKING REQUIREMENTS FOR COMMERCIAL TRAP GEAR IN STATE-WATERS

- In the surface system, there is to be one red mark measuring at least 3'.

- In the body of the buoy line, there are to be at least four solid or non-solid red marks measuring at least 2', with at least two marks occurring in the top 50% of the body of the buoy line and two marks occurring in the bottom 50% of the body of the buoy line.

- There is to be at least one solid or non-solid red mark for every 60' within the body of the buoy line.

- If fishermen are using buoy lines rigged with a weak contrivance

Buoy Line Marking Requirements for All Commercial Lobster and Crab Trap, Fish Pot and Whelk Pot Gear Set in MA State Waters



that is red (e.g., an insert of red or candy cane weak rope) or has a red tracer in it (e.g., certain South Shore sleeves) then the weak contrivance may double as a red mark in the body of the buoy line.

- If the buoy line is red, then all buoy line marks are to be white.

- No marks are to appear in the buoy line unless they are red marks, or white marks if the buoy line is red.

Buoy Line Marking Requirements for All Commercial Lobster and Crab Trap Gear Set in Federal Waters of LCMA 1, 2 and OCCLCMA



BUOY LINE MARKING REQUIREMENTS FOR MASSACHUSETTS COMMERCIAL LOBSTER AND JONAH CRAB POT/ TRAP GEAR IN FEDERAL WATERS WITHIN LCMA 1, LCMA 2, AND OUTER CAPE COD LCMA.

- In the surface system, there is to be one red mark measuring at least 3' and no more than 1' below the red mark there is to be a solid green mark measuring at least 1'.

- In the body of the buoy line, there are to be three solid or non-solid marks measuring at least 2' with at least one mark occurring in the top third, one mark occurring in the middle third, and one mark occurring in the bottom third.

- Each marks in the body of the buoy line are to be comprised of at least 1' of red and 1' green. While the green and red marks need not be adjacent, they cannot be spaced more than 6" apart.

- There are to be no red marks in the buoy lines that do not have a corresponding green mark.

- If fishermen are using buoy lines rigged with a weak contrivance that is red (e.g., an insert of red or candy cane weak rope) or has a red tracer in it (e.g., certain South Shore sleeves) then the weak contrivance may double as a red mark in the body of the buoy line.

- If the buoy line is the same color as one of the marks (i.e., red or green), then the mark with that color is to be replaced with a white mark.

Please visit our website at www.mass.gov/marinefisheries

WE DELIVER FRESH LOBSTER BAIT

INCLUDING:

HERRING

POGIES

MACKEREL

RED FISH

SKINS

BLUEFISH

CHUM

SALMON
HEADS



FRESH, SALTED, AND QUICK FROZEN BAIT

Barrel Head Bait

WE SELL SALT!

For More Information:

To Place An Order:

Mark Flight
mark@barrelheadbait.com

The Bait Line:
857-200-2129
Or Fax:
617-561-8471

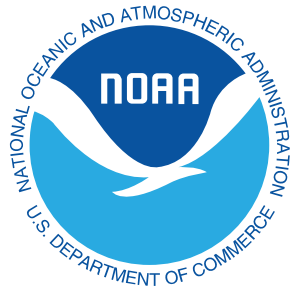

U.S. saw its coolest, driest January in eight years

The contiguous U.S. kicked off 2022 with its coolest January since 2014. However, the month still ranked nearly a degree warmer than average across the nation. January 2022 was also the driest January in eight years and among the top-15 driest Januaries on record.

Here are more highlights from NOAA's latest monthly U.S. climate report:

CLIMATE BY THE NUMBERS - JANUARY 2022

The average January temperature across the contiguous U.S. was 31.0 degrees F — 0.9 of a degree above the 20th-century average — ranking in the middle third of January months in the 128-year record.

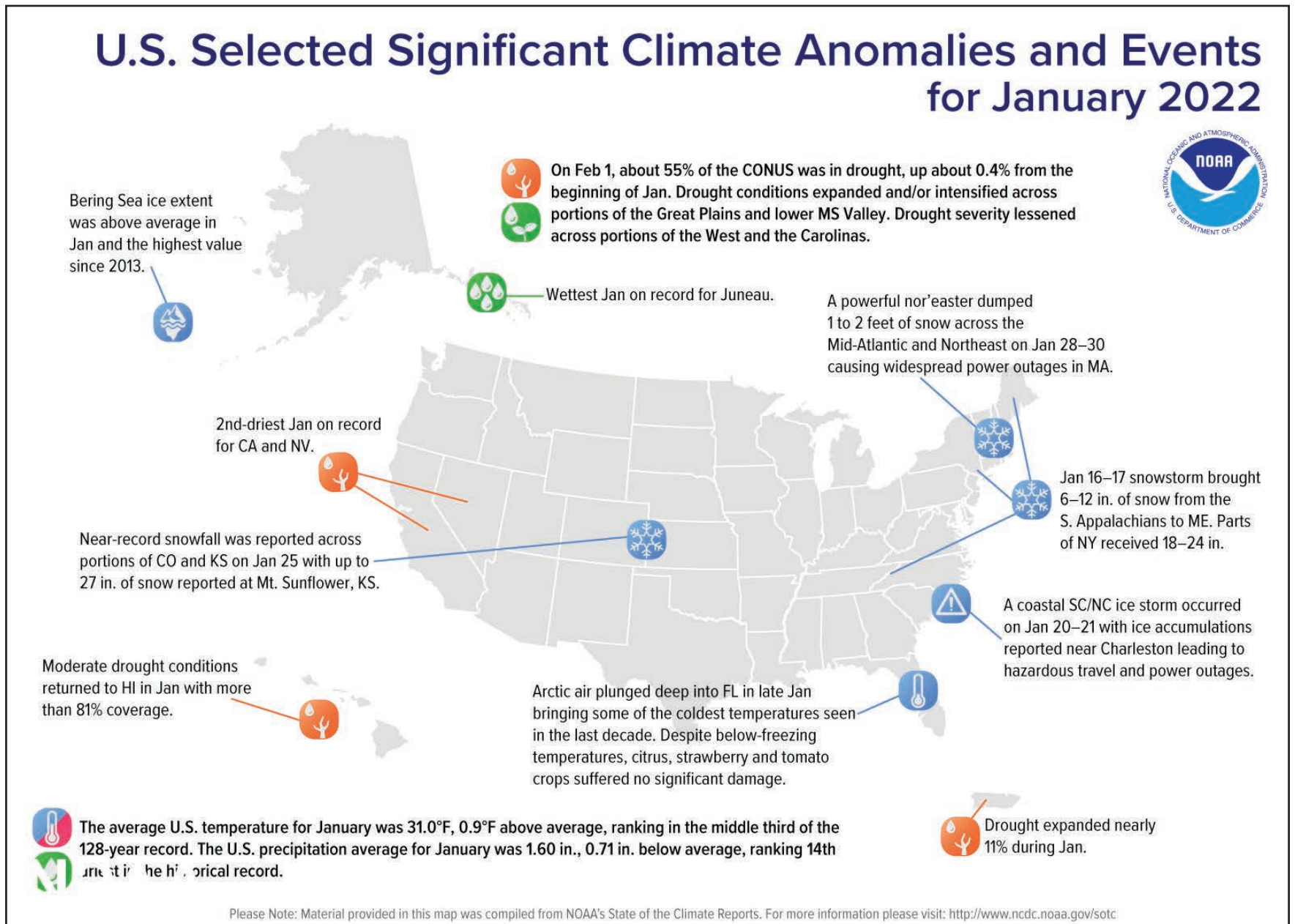

A map of the United States plotted with significant climate events that occurred during January 2022. Please see the story below as well as the full climate report highlights at <http://bit.ly/USClimate202201> Source: NOAA NCEI

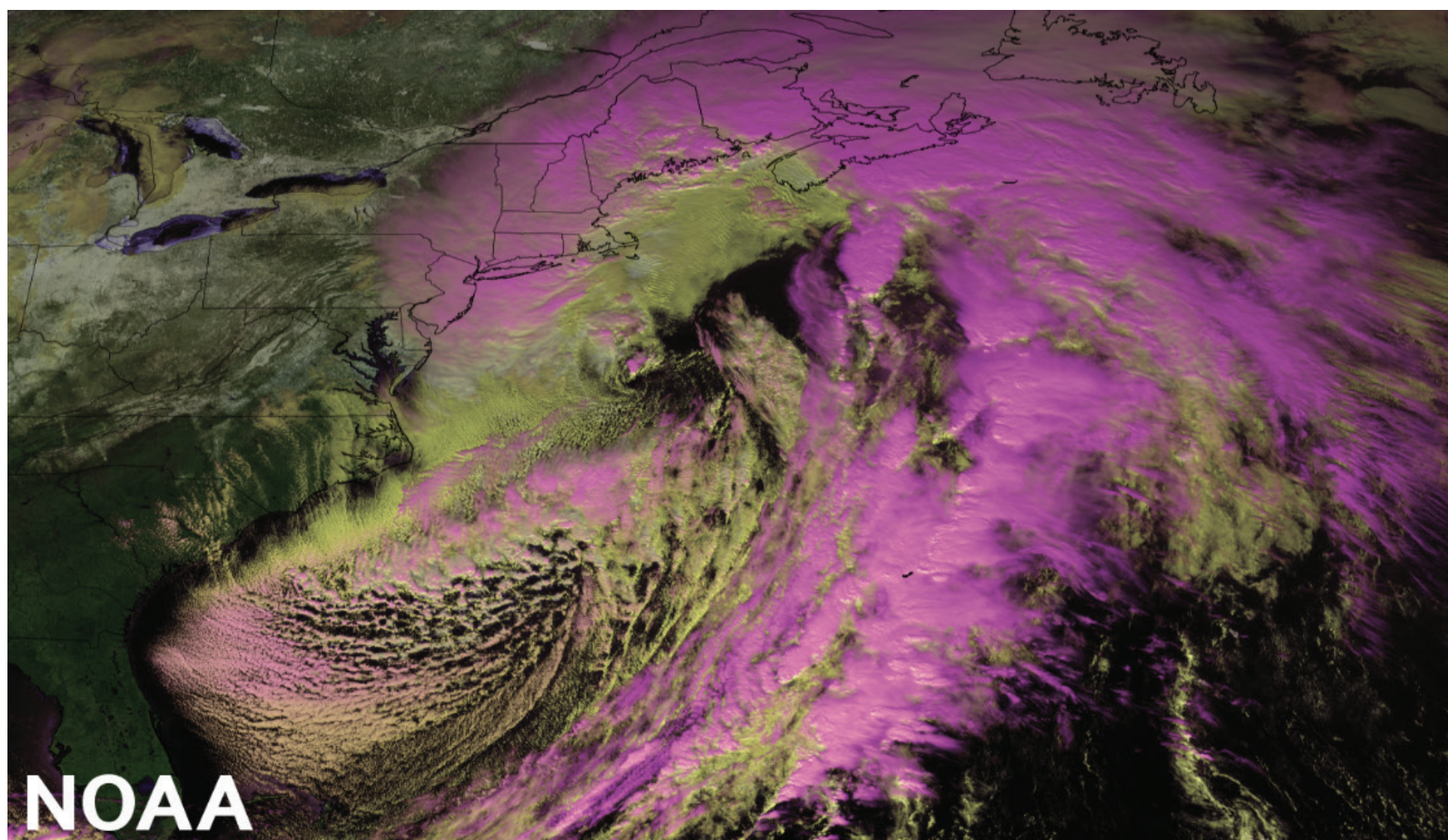

Source: NOAA

This view captured by NOAA's GOES-16 satellite shows a powerful nor'easter pounding the eastern U.S. on January 29, 2022. In this snow/cloud composite imagery, snow on the ground appears as white, low clouds appear as pale yellow and high clouds appear as light pink.

Temperatures were below average from the Midwest and Tennessee Valley to the Northeast, while temperatures were above average across much of the West and parts of the northern Plains. California saw its ninth-warmest January on record.

January precipitation for the contiguous U.S. was 1.60 inches (0.71 of an inch below average), tied with 2009 for 14th-driest January on record. It was also the driest January since 2014.

Precipitation was below average across much of the West, High Plains, Deep South, Great Lakes and Northeast. California and Nevada had their second-driest January, while Utah saw its third driest.

OTHER NOTABLE CLIMATE EVENTS FOR JANUARY 2022

- **“Bomb cyclone”** batters Northeast: A type of nor'easter known as a bomb cyclone rapidly intensified off the East Coast from January 28-30. The storm

dumped 1-2 feet of snow and brought blizzard conditions along the coastline from Delaware to Maine. On January 29, Boston, Massachusetts, tied its greatest one-day snowfall record — 23.6 inches.

- **Drought intensified last month:** According to the U.S. Drought Monitor, approximately 55.2% of the contiguous U.S. was in drought by the end of January, up 0.4% from the beginning of the month. Drought conditions expanded or intensified across portions of the Great Plains and lower Mississippi Valley. Drought severity lessened across portions of the West and the Carolinas.

NOAA Media Contact
John Bateman
202-424-0929

john.jones-bateman@noaa.gov

Article Source: <https://www.noaa.gov/news/us-saw-its-coolest-driest-january-in-8-years>



MARINE • FISHING GEAR • SAFETY
44 South Street, New Bedford, MA 02740

DSPA 5 M

OUR NEWEST FIRE PROTECTION

www.Hercules-SLR-US.com

JohnReardon@Hercules-SLR-US.com

USCG Safety Inspection Station #327

**Commercial Fishing-Marine
Safety-Rigging**

- ❖ Marine Hardware
- ❖ Cotesi - Netting, Leaded/Sink Rope
- ❖ Stormline & Climate Technical-Foul Weather Gear
- ❖ Buoys & Floats
- ❖ Lobster Bands
- ❖ PFD's, Vests, Float Coats
- ❖ Fish Totes
- ❖ Insulated Tubs
- ❖ Cordage & Twine
- ❖ Mooring Equipment
- ❖ Boarding Ladders
- ❖ Leadline
- ❖ Wire Rope - FC Galv, IWRC, Dyform
- ❖ HiFlyers 12', 14' & 15' XHD
- ❖ Golf & Batting Cage Netting



Inflatable PFD's



Fenders & Buoys-All Colors



Boots from
Honeywell Safety



ACR Electronics
Sales & Service
for your E.P.I.R.B.



Imperial Survival Suits
Inspections & Safety Drills

**Polysteel Rope- Esterpro
Sinking, Hydropro**

Call our USCG Certified Drill Conductor
Ted Williams 508-264-5779

"PULL THE PIN AND THROW IT IN"

44 South Street, New Bedford, MA 02740
Phone: 508-993-0010 Fax: 508-993-9005

Securing - Lifting - Rigging
82 MacArthur Dr. New Bedford, MA 02740
Phone: 508-992-9519 Fax: 508-992-9419

Life Raft Sales

- ❖ Revere
- ❖ Elliot
- ❖ Survitec
- ❖ Switlik

All brands accepted
for service

Ketcham Supply Store Special

Riverdale Mills Patch Wire Off Grade

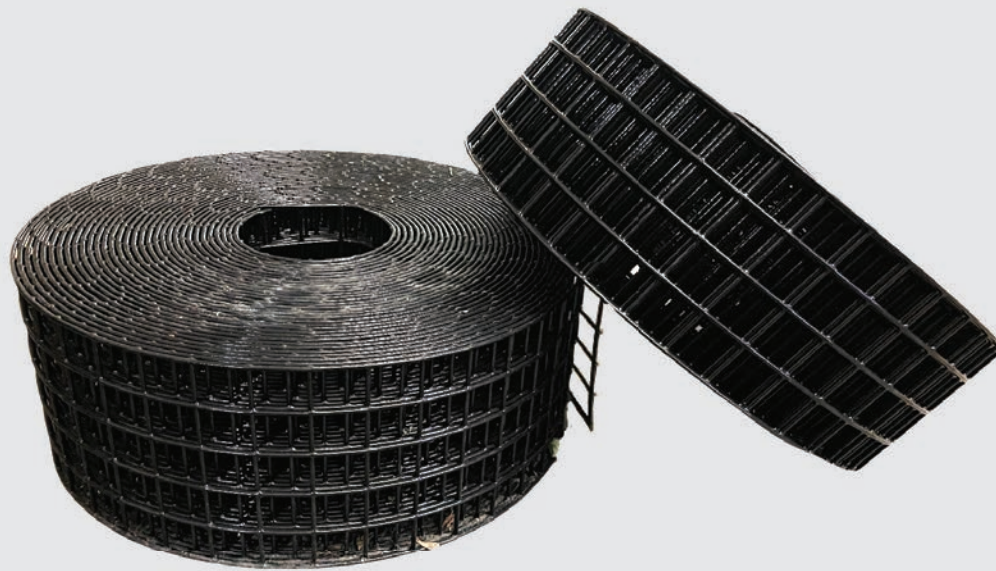

**1.5" Mesh
12.5 Gauge
100' Roll**

7.5 Inch (5 Mesh) Roll \$54

6 Inch (4 Mesh) Roll \$45

111 Myrtle Street
New Bedford, MA
🐦 @ketchamsupply



www.ketchamsupply.com
info@ketchamsupply.com
508.997.4787



The mission of the **Massachusetts Environmental Police**

is to protect the environment and natural resources of the Commonwealth of Massachusetts through enforcement, education, and public outreach.

If a violation is currently in progress, please call the Massachusetts Environmental Police Dispatch office at 1-800-632-8075.

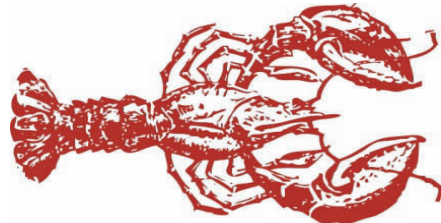
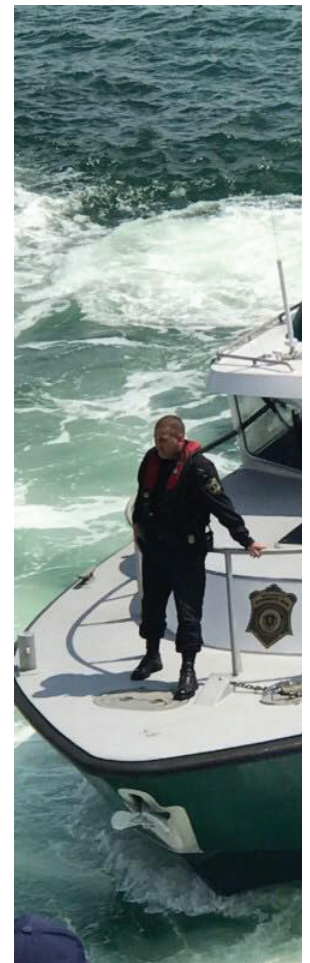

**“Specializing in the sale & delivery of
LOBSTER BAIT
for over 30 years”**

FRESH FROZEN AND SALTED BAIT AVAILABLE

**SKATES ~ HERRING ~ POGIES ~ HADDOCK ~ COD FISH ~ POLLOCK
FLAT FISH ~ FISH SKINS ~ RED FISH ~ DOG FISH HEADS ~ SALMON**



**C & P BAIT
33 Wright St
New Bedford, MA 02740**

**Contact:
Danny Costa 508-951-9818
Carlos Pereira 508-951-9819**



Atlantic States Marine Fisheries Commission

AMERICAN LOBSTER MANAGEMENT BOARD *February 22, 2002 – Meeting Summary*

The American Lobster Management Board (Board) met to consider public comments, input from the American Lobster and Jonah Crab Advisory Panels (APs), and final action on Draft Addenda XXIX and IV to the American Lobster and Jonah Crab FMPs, respectively, on electronic tracking requirements in the federal American lobster and Jonah crab fisheries. In response to requests from the public for more information on the proposed management program, the Board agreed to postpone considering final action on the Draft Addenda until its next meeting, which is to be held virtually sometime prior to the ASMFC Spring Meeting.

The Draft Addenda were initiated in August 2021 to consider electronic tracking requirements for federal permit holders in the American lobster and Jonah crab fisheries. The purpose of the proposed action

is to address a critical need for high-resolution spatial and temporal data to characterize effort in the federal American lobster and Jonah crab fleet. Spatial data collected by tracking devices would benefit managers in contending with several challenges facing the fisheries, including Atlantic right whale risk reduction efforts, marine spatial planning discussions, stock assessment, and offshore enforcement. The Draft Addenda include two options for proposed management programs. The first is status quo or no change, and the second is to implement electronic tracking requirements for federally-permitted lobster and Jonah crab vessels with commercial trap gear area permits for Lobster Conservation and Management Areas 1, 2, 3, 4, 5, and Outer Cape Cod. Under this option, the specified permit holders would be required to install an approved electronic vessel tracking de-

vice to their vessel prior to beginning a fishing trip to collect and transmit spatial data.

The majority of public comments, as well as advice from American lobster and Jonah crab advisors, supported the status quo option. In large part this was the result of many remaining questions about the tracking devices, costs to industry, and standard procedures that would need to be followed by harvesters and states to successfully implement requirements for electronic vessel tracking. Therefore, the Board agreed to postpone consideration of final action. Instead, the Board engaged in further discussion on questions that had been raised by the public and APs about how the program would work in practice. The Board requested that staff work with the Plan Development Team, state managers, NOAA Fisheries, and ACCSP to provide additional details

to the Board on standard operating procedures. The Board is expected to meet to consider this information and Draft Addendum XXIX for final approval in late March or early April. A press release will announce the timing of that meeting.

For more information, please contact Caitlin Starks, Senior Fishery Management Plan Coordinator, at cstarks@asmfc.org or 703.842.0740.

MOTIONS

Move to postpone action on Lobster Draft Addendum XXIX and Jonah Crab Draft Addendum IV until the next meeting of the American Lobster Management Board, which will be held before the ASMFC Spring Meeting.

Motion made by Ms. Paterson, and seconded by Mr. Borden. Motion passes (11 in favor).



MLA letter of comment on Draft Addendum XXIX

January 24, 2022

Caitlin Starks
Atlantic States Marine Fisheries Commission
1050 N. Highland St. Suite 200A-N
Arlington, VA 22201

RE: Draft Addendum XXIX

Dear Ms. Starks,

The Massachusetts Lobstermen's Association submits this letter of comment on behalf of its' 1800 members on the; Atlantic States Marine Fisheries Commission on DRAFT ADDENDUM XXIX TO AMENDMENT 3 TO THE AMERICAN LOBSTER FISHERY MANAGEMENT PLAN & DRAFT ADDENDUM IV TO THE JONAH CRAB FISHERY MANAGEMENT PLAN (Addendum XXIX) Electronic on Vessel Tracking for Federal Permit Holders.

While the objective of Addendum XXIX is to give a high resolution and temporal image on effort data to better depict what the effort is of the commercial lobster industry to better serve new users. The MLA does not support the implementation of vessel tracking systems for the commercial lobster industry as a management measure to better serve stock assessments, protected species interactions, marine spatial planning, and offshore enforcement. The MLA is deeply active in all of these areas and is wary that vessel tracking will benefit the commercial lobstermen and be anything but another expense.

Established in 1963, the MLA is a member-driven organization that accepts and supports the interdependence of species conservation and the members' collective economic interests. The membership is comprised of fishermen from Maryland to Canada and encompasses a wide variety of gear types from fixed gear and mobile gear alike. The MLA continues to work conscientiously through the management process with the Division of Marine Fisheries, Atlantic States Marine Fisheries, Atlantic Large Whale Take Reduction Team, and the New England Fisheries Management Council to ensure the continued sustainability and profitability of the resources in which our commercial fishermen are engaged in.

The commercial lobstermen have been reporting their locations for many years now, and this data ought to be used as it is available today and free. The commercial lobster industry complied to the implementation of the 10-minute squares to give even a better depiction of the commercial lobster fisheries spatial foot-print and now, that is not good enough. The commercial lobster industry is continually being "asked" to do more, and at their expense, for the betterment of stock assessments, protected species interactions, marine spatial planning, and offshore enforcement without any compensation or appreciation. The MLA does not support any more and unnecessary financial burden to be placed on the commercial lobstermen.

During the recent public hearings on Addendum XXIX there were several comments on the use of these vessel tracking systems and who will have access to the data. As we are watching the industrialization of the Exclusive Economic Zone (EEZ), whether is it aquaculture or offshore wind, the MLA is concerned that this data will paint the commercial lobster industry into a corner, a box, and or right off the water. Zoning the ocean into user groups is being foreshadowed here, and the MLA cannot support the implementation of vessel tracking.

For the reasons noted above, the Massachusetts Lobstermen's Association SUPPORTS Option A: Status quo Under this option no changes to current management and monitoring requirements for lobster and Jonah crab would be implemented.

Thank you for your thoughtful deliberation and consideration on our comments.

Sincerely,
Beth Casoni
MLA, Executive Director

HM45
YEARS
**HAMILTON
MARINE**
BOATERS' STORE™

**OPEN
HOUSE 2022**
APRIL 2ND-10TH *Don't Miss It!*

KITTERY • PORTLAND • ROCKLAND • SEARSPORT • SW HARBOR • JONESPORT

REQUEST FREE
2022
Catalog
IN MARCH

JOIN OUR CREW!

Do you love boats & boating? Do you love being on the water and want to share your experiences with a great crew or be trained to learn the industry? Hamilton Marine is looking for candidates to join the team in a hardworking but casual, family-oriented atmosphere who have a positive attitude and a strong commitment to teamwork and service. Many positions available, flexible hours, full & part time positions, substantial employee discount and many more benefits!

Apply today in store or at hamiltonmarine.com/careers

📞 800-639-2715

🌐 hamiltonmarine.com





@patriots

I couldn't have dreamed of a better ride ❤️





New England Marine & Industrial
www.newenglandmarine.com

Lobster Bands

We carry:

Sheddar

Standard

Cold Water Shedder

Jumbo



Buy them by the 1 pound bag, by the case or by the pallet. We also offer wholesale and volume discounts. Call and ask to speak to a salesman.



Dayglo &
Flexabar
Buoy Paint



Perone Buoys

Full selection of sizes
in Stock

Riverdale/Aquamesh Trap Wire

- Large inventory of trap wire in store
- Variety of sizes and colors available
 - Some trap kits in stock
- Order any size trap kits you may need

200 Spaulding Tpke
Portsmouth, NH
603-436-2836

294 Ocean St
Brant Rock, MA
781-834-9301

86 Cemetary Rd
Stonington, ME
207-367-2692

Dumping

FROM PAGE 1

unconscionable and will jeopardize thousands of jobs here in the Commonwealth as well as the vast and diverse marine life in our waters.

Furthermore, on January 28, 2022 Congressman Keating sent a letter to the U.S. Nuclear Regulatory stating that “The process of “overboarding” this material is simply the least expensive manner of disposing the irradiated waste remaining at Pilgrim Nuclear Power Station. Other alternatives exist to manage this waste that will not delay the ongoing decommissioning process. As you are aware, options include solidifying the waste and shipping it to a low hazard waste facility in Idaho. Discharging millions



Congressman William R. (Bill) Keating represents Massachusetts' 9th Congressional District, which encompasses the state's South Shore, South Coast, Cape Cod and the Islands of Martha's Vineyard, and Nantucket.

of gallons of irradiated material into Cape Cod Bay is the wrong decision for my constituents and will have long-lasting negative impacts on a community that has been burdened for decades by the presence of a nuclear power

plant. This issue is fundamental to considering the environmental justice impacts that have already occurred in our communities because of Pilgrim.”

Many of you have been fol-

lowing this most serious issue and have participated during the recent speak-outs and rallies and for that we say “THANK YOU”. We need to keep the pressure on our elected officials to put this to an end now and forever.

If you would like to get involved please send an email request to beth.casoni@lobstermen.com and we will send along all the information on upcoming events and legislative efforts.



Are you thinking of buying or selling?

Boats | State and Federal Permits | Complete Businesses

ATHEARN MARINE AGENCY, INC.



SERVING FISHERMEN SINCE 1946

Tel: (508) 999-4505

Email: sales@athearnmarine.com

www.athearnmarine.com

10 Union Wharf, Fairhaven, MA 02719





The Commonwealth of Massachusetts Division of Marine Fisheries

251 Causeway Street, Suite 400, Boston, MA 02114

p: (617) 626-1520 | f: (617) 626-1509

www.mass.gov/marinefisheries



CHARLES D. BAKER
Governor

KARYN E. POLITO
Lt. Governor

KATHLEEN A. THEOHARIDES
Secretary

RONALD S. AMIDON
Commissioner

DANIEL J. MCKIERNAN
Director

January 26, 2022

Prohibition on Setting of Lobster Trawls in Gosnold Waters is Eliminated

The Massachusetts state legislature has amended G.L. c. 130, §37 and struck the long-standing prohibition on the fishing of lobster trap trawls in the waters of the Town of Gosnold. This change in state law is effective immediately. Permitted lobstermen may now set and fish multiple trap trawls within these town waters or continue to fish single traps (where every trap has its own buoy line) if that is their preference. See map on the right for a visual depiction of Gosnold town waters.

The Division of Marine Fisheries sought this amendment to reduce buoy lines and any associated risk of entanglement with protected species such as whales and leatherback turtles. As a consequence of this statutory change, there is no longer any area in state waters where single trap fishing is mandated.

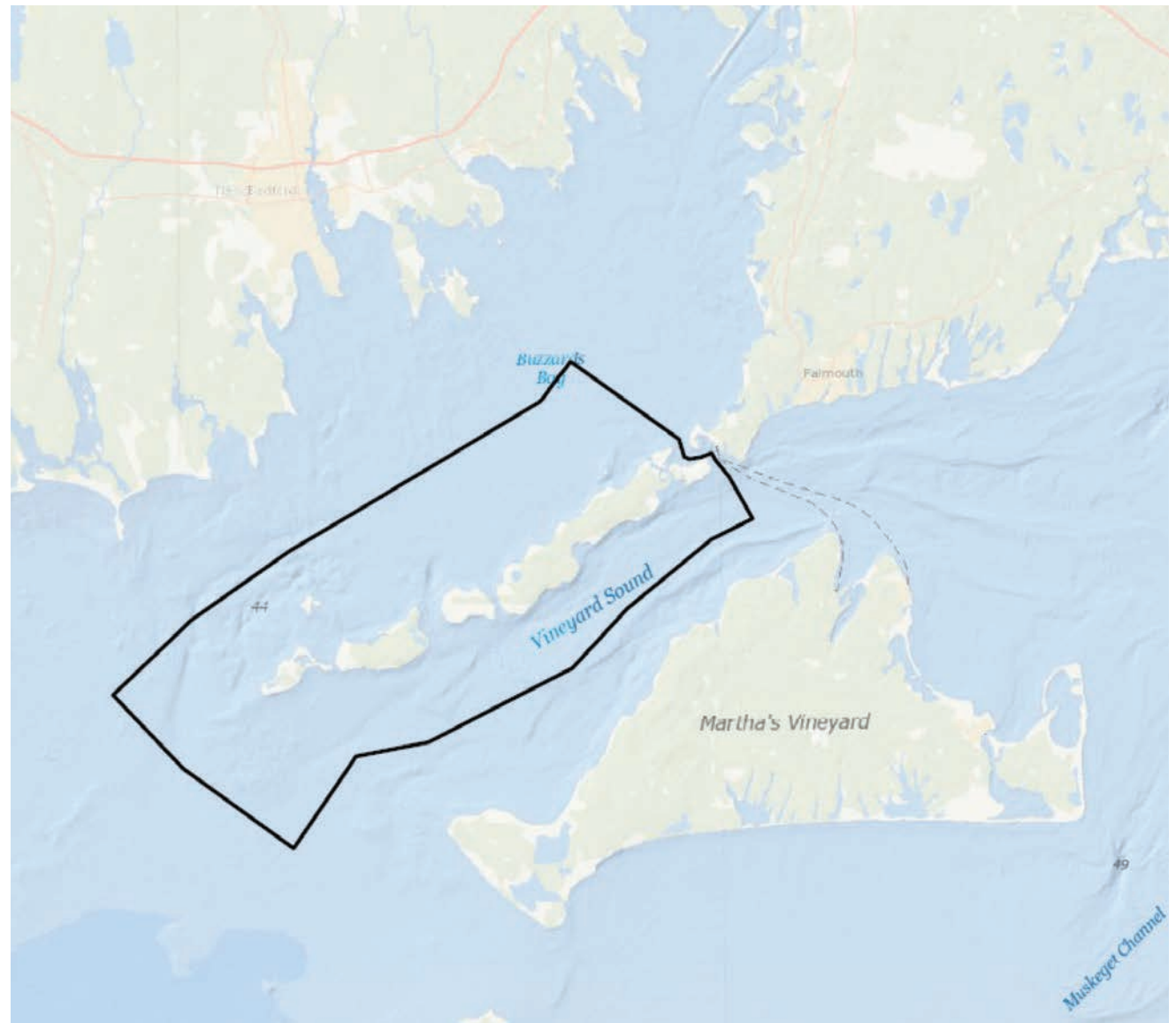

Please visit our website at www.mass.gov/marinefisheries



***Cape Seafoods Bait Shop
Kicking off the Season!***



THE LARGEST BAIT VARIETY IN THE ATLANTIC NORTHEAST

In operation since 2001 and still going strong!

Trust Us for Your Fresh, Salted & Frozen Bait Needs

From (1) Carton to a Full Truck Load.

**Herring, Mackerel, Pogies, Redfish, Rockfish, Tuna, Monkfish, Sardines,
Plaice, Squid, Sea Robin, Halibut, & Silversides.**

We've got you covered!

Great News...We now buy Lobster, too!

Open Year Round (Serving clients 7 Days a Week from Mid-June To Mid-October)

Monday-Friday 5AM-3PM, Saturday 6AM-12PM & Sunday 6AM-10AM

Main Phone Line: 978.283.8522

Bait Shop Phone Line : 978.479.4642

If we don't have it... Please ask and we'll find it!

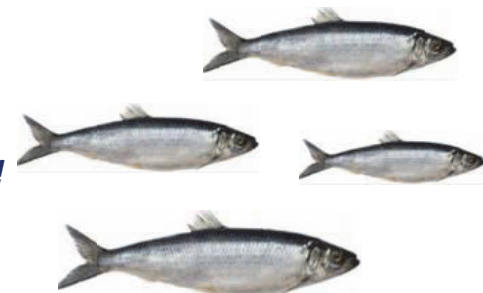

AQUAMESH®

Premium Quality Marine Wire



Proudly
Made in the USA
Since 1980

*Contact us today to locate
a distributor in your area!*



1.800.762.6374 • SALES@RIVERDALE.COM • WWW.RIVERDALE.COM



NROC
Northeast Regional
Ocean Council

SAVE THE DATES

Webinar Series | April 5 and April 8, 2022

Aquaculture in New England Federal Waters: Regulation, Public Engagement and Interjurisdictional Coordination

The Northeast Regional Ocean Council (NROC)'s Ocean Planning Committee (OPC) invites you to participate in a webinar series about the regulatory process, public engagement, and interjurisdictional coordination for aquaculture in New England federal waters. This series builds on NROC's 2020 webinar which highlighted federal efforts to designate Aquaculture Opportunity Areas in the United States, as well as NROC's recent development of a draft set of "Best Practices for Ocean Permitting and Management Processes."

These webinars will provide an overview of the state of aquaculture in New England federal waters, an update on the identification of Aquaculture Opportunity Areas, an overview of the federal review and authorization process for aquaculture activities, and discussion about how federal agencies coordinate with states, tribes, and the public to consider environmental and human impacts during regulatory review. Panel sessions will highlight state, tribal, and public perspectives on opportunities to improve the federal regulatory review process and better engage different interests in aquaculture permitting decisions.

WEBINAR 1

Tuesday, April 5, 2022 | 9:00 - 11:00 AM

Federal Agency Review and Authorization of Aquaculture in New England Federal Waters

Learn about the state of aquaculture in New England, identification of Aquaculture Opportunity Areas, case studies of aquaculture permitting from other regions, and the federal agency review and authorization process for aquaculture in New England federal waters. Speakers will include NROC OPC Co-Chair Lou Chiarella, NOAA Fisheries; Chris Schillaci, NOAA Fisheries; Christine Jacek,

US Army Corps of Engineers; and Eric Nelson, US Environmental Protection Agency. Webinar participants will have an opportunity to ask questions and provide comments following the presentations.

WEBINAR 2

Friday, April 8, 2022 | 9:00 - 11:00 AM

State, Tribal, and Public Perspectives on Improving the Regulatory Process for Aquaculture in New England Federal Waters

Panel sessions will highlight state, tribal, and public perspectives on improving the regulatory process for aquaculture permitting in New England. Speakers will include: NROC OPC Co-Chair Ted Diers, New Hampshire Department of Environmental Services; Chris Schillaci, NOAA Fisheries; Chuckie Green, Mashpee Wampanoag Tribe; Tom Nies, New England Fisheries Management Council; Lisa Engler, Massachusetts Office of Coastal Zone Management; Chris Williams, New Hampshire Department of Environmental Services; Amanda Ellis, Maine Department of Marine Resources; Sebastian Belle, Maine Aquaculture Association; Ted Maney, Salem State University; Paul Zajicek, National Aquaculture Association; Beth Casoni, Massachusetts Lobstermen's Association; Robert Jones, The Nature Conservancy; and Priscilla Brooks, Conservation Law Foundation. Webinar participants will have an opportunity to ask questions following each panel session.

COMING SOON!

Registration and program details will be available in March 2022 via NROC's ocean planning website:

neoceanplanning.org/planning-issues/aquaculture/

UPDATE: Project Communications and Management Changes



Dear Fishermen,

On January 10, 2022 the two owners of Vineyard Wind, Avangrid Renewables and Copenhagen Infrastructure Partners (CIP), announced the completion of a restructuring:

- The Vineyard Wind 1 project in lease area OCS-A 0501 continues to be developed as a 50/50 joint venture between the two partner companies and will deliver 800 MW to Massachusetts.

- Avangrid Renewables is the sole developer of lease area OCS-A 0534, which includes Park City Wind, an 804 MW project which will deliver clean energy to Connecticut, and Commonwealth Wind, a 1,232 MW project which will deliver clean energy to Massachusetts; together, the projects are undergoing regulatory review as “New England Wind”.

- CIP is the sole developer of lease area OCS-A 0522 for which there are currently no actively proposed projects.

It is important to both project partners to continue to provide fishermen with timely communications of ongoing activities related to all three offshore wind projects and future projects.

If you are interested in receiving updates from **Vineyard Wind** on the Vineyard Wind 1 project- OCS-A-501 and

OCS-A-522 please sign up for email alerts at vineyardwind.com/fisheries or text alerts by texting vwfisheries to 844-621-2170.

If you are interested in receiving updates from **Avangrid Renewables** in relation to New England Wind-OCS-A-534 (Park City Wind and Commonwealth Wind) please sign up for email alerts at parkcitywind.com/learn-more.

Crista Bank remains the Fisheries Manager for Vineyard Wind (cbank@vineyardwind.com) and Caela Howard is the Fisheries Liaison for Avangrid Renewables (caela.howard@avangrid.com). We will continue to coordinate closely with each other on all projects.

Sincerely,
Crista and Caela

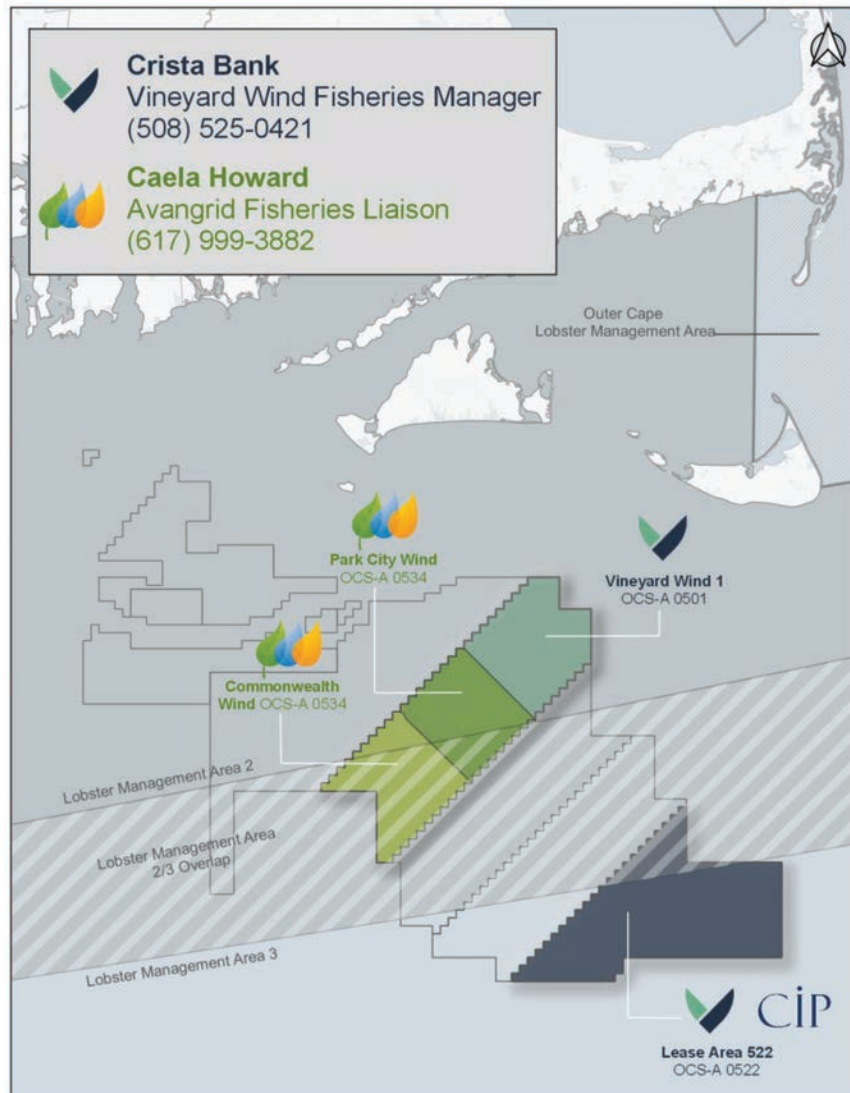

CONTACT US

VINEYARD WIND
Crista Bank, Fisheries Manager:
cbank@vineyardwind.com
508-525-0421

AVANGRID RENEWABLES
Caela Howard, Fisheries Liaison
Park City Wind & Commonwealth Wind
caela.howard@avangrid.com
617-999-3882



**EVENT
POST-
PONED**

Annual Weekend & Industry Trade Show 2022

POSTPONED Until March 23-26, 2023

Due to the ongoing pandemic and the COVID-19 variants, the Massachusetts Lobstermen's Association Annual Weekend & Industry Trade Show 2022 has been postponed until March 23-26, 2023.

The MLA Delegates have made this very hard decision to postpone the Annual Weekend & Industry Trade Show 2022 after a long discussion and great consideration. The MLA Delegates unanimously agreed that there was no possible way to protect the staff, attendees and exhibitors alike from all the Covid-19 variants.

Please keep an eye on the MLAs website www.lobstermen.com and social media outlets for more information on the Massachusetts Lobstermen's Association Annual Weekend & Industry Trade Show has been postponed

until March 23-26, 2023.

The Massachusetts Lobstermen's Association Annual Weekend & Industry Trade Show 2023 will be held at the Resort and conference Center at Hyannis, 35 Scudder Ave., Hyannis, MA 02601

The Massachusetts Lobstermen's Association Annual Weekend & Industry Trade Show has been a hugely successful event and we want to keep it that way.

If you have any immediate questions, please email; beth.casoni@lobstermen.com or call 781-545-6984 xt. 1

Be well and continue to stay healthy,
Annual Weekend Committee

OVER 20 YEARS EXPERIENCE ~ ALL MATERIALS & SIZES

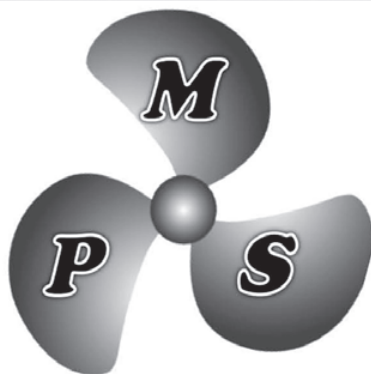

**FOR FAST SERVICE
CALL MIKE @
508.979.8000**

marine.propeller128@gmail.com

MARINE

PROPELLER SERVICE

REPAIRS &
RECONDITIONING
(Fast & Fully Insured)

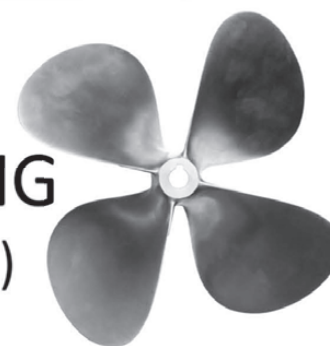

THE MOST RELIABLE PROPELLER SERVICE COMPANY ON THE SOUTHCOAST

74 MAIN STREET FAIRHAVEN MA 02719 508.979.8000 FAX 774.206.6449



Rose Marine

Gloucester, MASS www.rosesmarine.com

877-283-3334

Aqualoy Stainless Propeller Shafts & Accessories



Largest stock of **Aqualoy** Stainless Prop Shafting on the East Coast
With *Emergency* turn-around time available.

Call or e-mail Peter Tetrault for a price on your next shaft.
peter.tetrault@rosesoil.net



- All Seamless Tubing
- High pressure available
- 90/10 copper-nickel
- 2" to 5" Dia. Body in stock



- Stainless Steel Wrapped
- Teflon Core
- Super Low friction

Ask for the "GREEN MARINE" cable

KOBELT
Controls



Anchor Flush Mount Hatches

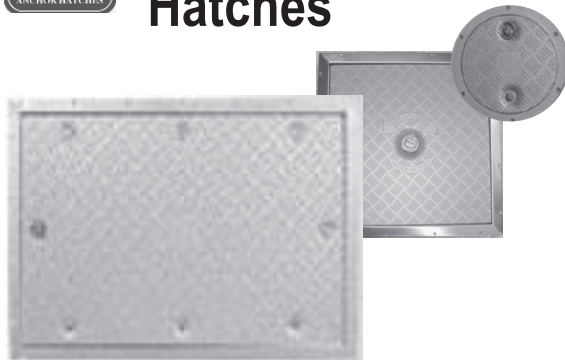

Mufflers and Exhaust Components



Stainless Steel Mufflers
And Accessories
2" – 8" inlet size in stock





Rose Marine

Gloucester, MASS www.rosesmarine.com

877-283-3334

Sales and Service of Hydraulic Components

We will customize a hydraulic hauling or power-steering system to fit your exact needs.

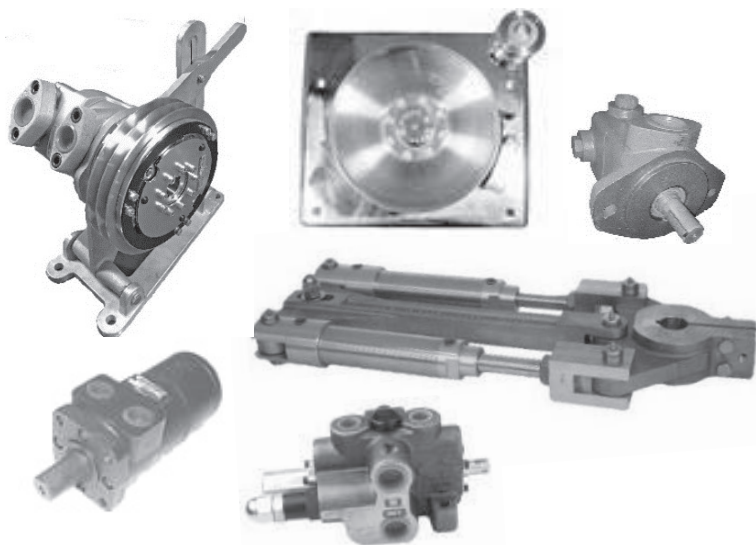

Authorized SEASTAR Solutions (FORMERLY Teleflex)
Repair Facility for the Northeastern U.S.



Complete Line of
Johnson Pump®
Pumps & Parts

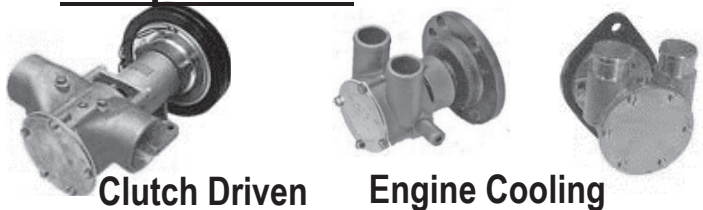

Clutch Driven

Engine Cooling



Hydraulic Driven

Sized to the flow rate to fit your boat.

Complete Line of
PACER
Pumps & Parts

PACKLESS SEALING SYSTEM
SHAFT SEAL



Stocking Distributor

Combination Shaft Zinc & Line Cutters



Shaft Sizes
3/4" to 2-1/4"





New England Marine Engineering & Supply, Inc.

Marine • Industrial • Commercial • Refrigeration

10 TON ELECTRIC TITANIUM RSW
INTEGRATED MARINE SYSTEMS

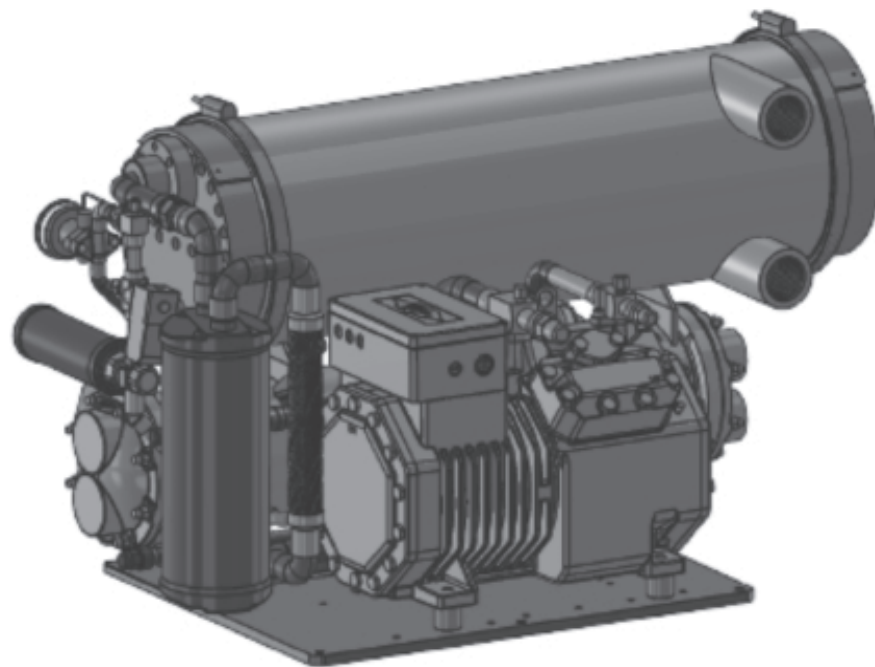

"New England Marine Engineering & Supply, Inc & Integrated Marine Systems, Inc is proud to announce & debut the new IMS 10 Ton Titanium Electric RSW at the 2018 Seafood Processing North America Show on March 11-13 Booth 1875. Come see us and be the first to view the latest IMS system to be introduced to the industry for the fishing vessels ranging from 40' - 80'.

It's going to be the talk of the show."

133 North Front Street, New Bedford, MA. 02740

www.nemesinc.com 1.800.540.8893



NEW ENGLAND/MID-ATLANTIC

Questions? Contact Sarah Sullivan, Safety Operations Specialist,
Fisheries Monitoring Operations Branch at 508-524-3039

Changes in Life Raft Requirements for Commercial Fishing Vessels

The Northeast Fisheries Observer Program will be discontinuing the usage of supplemental valise life rafts by observers and at-sea monitors on **June 30, 2023**. According to 46 U.S.C. § 4502(b)(2)(B) it is the vessel's responsibility to have a properly installed life craft, when applicable, with capacity to hold all persons on board, including the observer.

Vessels selected for observer or at-sea monitor coverage must meet all U.S. Coast Guard (USCG) safety regulations and must also display a current USCG Commercial Fishing Vessel Safety Examination decal. These requirements are outlined in the USCG Federal Requirements for Commercial Fishing Industry Vessels. All safety equipment, servicing, and registrations must be present and current (i.e. not expired). A checklist of the required safety gear can be created using the USCG Commercial Fishing Vessel Checklist Generator.



USCG COMMERCIAL FISHING VESSEL SAFETY EXAMINATION				
Vessel Name:		I.D. Number:		
Call Sign:	Other Identifier:			
Hull Color:	Trim Color:	Superstructure Color:		
Vessel Length:	Gross Tonnage:	Maximum POB:		
Hull Type: <input type="checkbox"/> Wood <input type="checkbox"/> Aluminum <input type="checkbox"/> Fiberglass <input type="checkbox"/> Steel <input type="checkbox"/> Other (specify):		Vessel Type: <input type="checkbox"/> Fishing Vessel <input type="checkbox"/> Fish Tender <input type="checkbox"/> Fish Processing Vessel		
Year Built:		Year Converted:		
Propulsion: <input type="checkbox"/> Outboard <input type="checkbox"/> Inboard <input type="checkbox"/> Inboard/Outboard		Horsepower:	Number of Shafts:	
Decal Info: <input type="checkbox"/> Initial Issue <input type="checkbox"/> Renewal If a renewal, date last decal issued: _____		Fishing Equipment: <input type="checkbox"/> Long Line <input type="checkbox"/> Multi-Rig <input type="checkbox"/> Troll <input type="checkbox"/> Gill Net <input type="checkbox"/> Tender <input type="checkbox"/> Trawl <input type="checkbox"/> Purse Seine <input type="checkbox"/> Trap <input type="checkbox"/> Bottom <input type="checkbox"/> Other (specify):		
Fuel: <input type="checkbox"/> Gas <input type="checkbox"/> Diesel <input type="checkbox"/> Portable <input type="checkbox"/> Fixed (vented)		Number of Fuel Tanks:		
Lube Oil Capacity (gal):	Hydraulic Oil Capacity (gal):	Fuel Capacity (gal):		
Route: <input type="checkbox"/> Inland <input type="checkbox"/> Waters Inside Coastal Waters <input type="checkbox"/> Coastal Waters				
Boundary Line: <input type="checkbox"/> Inside <input type="checkbox"/> Outside <input type="checkbox"/> <3nm <input type="checkbox"/> <12nm <input type="checkbox"/> <20nm <input type="checkbox"/> <50nm <input type="checkbox"/> >50nm <input type="checkbox"/> >100nm				
Applicable Waters: <input type="checkbox"/> Warm <input type="checkbox"/> Cold				
Owner:		Contact Person:		
Owner Address:		Contact Address:		
Owner Phone:		Contact Phone:		
Exam Requested Due To:	<input type="checkbox"/> 4100 Boarding <input type="checkbox"/> Owner <input type="checkbox"/> Family Member <input type="checkbox"/> Observer Coverage <input type="checkbox"/> Exemption <input type="checkbox"/> Other (specify):			
How did requester hear about program?				
A voluntary dockside examination has been completed on this vessel but a Commercial Fishing Vessel Safety Decal cannot be issued due to the deficiencies listed below and on the Continuation Sheet. (Deficiencies are listed by citation number with an explanation of the item(s) not in compliance, or identification of any particularly hazardous condition(s):				
When these deficiencies are corrected, please call _____ to schedule a re-examination.				
Examiner's Name:		Examiner's Unit:		
Date of this Exam:		Location:		
CONGRATULATIONS! Your vessel has been examined and is in compliance with all applicable safety regulations. Commercial Fishing Vessel Safety Decal Number _____ has been issued. The decal is valid until the date indicated on the Decal provided the vessel safety equipment remains serviceable and the operating conditions described above are not exceeded. The Decal is to be removed from the vessel if the vessel is sold. This form should be kept on board your vessel so it can be shown to the Coast Guard if your vessel is boarded.				
Issuing Examiner's Signature:			Date Issued:	
Vessel Representative's Signature:				
Official Use Only				
HOURS	Exam:	Travel:	Training:	Training Travel:
Department of Homeland Security		EXAMINER COPY		
United States Coast Guard				
CG-5587 (6/08) Previous editions may be used.				



The Commonwealth of Massachusetts Division of Marine Fisheries

251 Causeway Street, Suite 400, Boston, MA 02114

p: (617) 626-1520 | f: (617) 626-1509

www.mass.gov/marinefisheries



CHARLES D. BAKER
Governor

KARYN E. POLITO
Lt. Governor

KATHLEEN A. THEOHARIDES
Secretary

RONALD S. AMIDON
Commissioner

DANIEL J. MCKIERNAN
Director

February 4, 2022

Expansion of Seasonal Gillnet Closure to Protect Right Whales

The Division of Marine Fisheries has expanded the spatial extent of the January 1 – May 15 seasonal sink gillnet closure to protect right whales. Whereas this closure previously only ap-

plied in Cape Cod Bay, it now applies throughout all Massachusetts state waters. This extended closure is effective for this calendar year.

This closure is designed to mitigate the risk of a right

whale becoming entangled in this fixed gear when they seasonally aggregate in and migrate through our waters. Of particular concern was the potential co-occurrence of gillnet gear and right

whales in Massachusetts Bay and off Cape Ann during April and early May. In recent years, right whale sightings data show right whales are increasingly using these waters during this time.

Please visit our website at www.mass.gov/marinefisheries



Encore Hartco Tools & Clips
Stanley Spenax Tools & C-Rings
Wematic Tools & D-Rings
Simonds Pneumatic Wire Cutters
Spotnail Staplers & Staples



(781) 826-2522
Fax (781) 826 5252
www.fisherairfasteners.com
chris@fisherairfasteners.com

Complete Parts Inventory
Tool Repair Service

REPOWER your boat with a new Cummins diesel engine.



QSB6.7
250-480 HP



QSC8.3
500 HP

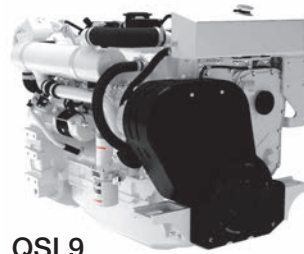

QSL9
290-410 HP



QSM11
610 HP

Contact your local Cummins distributor or dealer for complete program details.

Steve Nadeau - MA, ME, RI and Upstate NY
207-510-2247 | steve.nadeau@cummins.com

Will Collins - MA, RI, CT and NY
781-801-1772 | will.collins@cummins.com

NETWORK OF MARINE ENGINE DEALERS THROUGHOUT NEW ENGLAND

Billings Diesel and Marine
Stonington, ME
(207) 367-2328

Great Bay Marine
Newington, NH
603-436-5299

James Rich Boat Yard
Southwest Harbor, ME
(207) 244-3208

Niemiec Marine
New Bedford, MA
(508) 997-7390

Brewers' Plymouth Marine
Plymouth, MA
(508) 746-4500

Gorham's Diesel Repair, Inc.
Braintree, MA
(781) 843-0816

Journey's End Marina
Rockland, ME
(207) 594-4444

Point Judith Marina
Wakefield, RI
(401) 789-7189

Brewer Greenwich Bay
Warwick, RI
(401) 884-0544

Hinckley Yacht Services
Portsmouth, RI
(401) 683-7100

**Kennedy Marine
Engineering & Fabrication**
Steuben, ME
(207) 546-7139

Port Niantic Inc
Niantic (East Lyme), CT
(860) 739-2155

Bristol Marine
Bristol, RI
(401) 253-2200

Hinckley Yacht Services
Southwest Harbor, ME
(207) 244-5572

Kingman Yacht Center
Cataumet, MA
(508) 563-7136

**Rhode Island
Engine Co., Inc.**
Narragansett, RI
(401) 789-1021

Cape Ann Marine
Gloucester, MA
(978) 283-2116

Hodgdon Yacht Services
Southport, ME
(207) 633-2970

**MacDougall's Cape Cod
Marine Service**
Falmouth, MA
(508) 548-3146

Russ Marine Service
Peabody, MA
(978) 532-3373

Casco Bay Diesel
Portland, ME
(207) 878-9377

Hyannis Marina
Hyannis, MA
(508) 775-5662

Merri-Mar Yacht Basin
Newburyport, MA
(978) 465-3022

Great Island Boat Yard
Harpwell, ME
207-729-1639

Independent Field Service
Dewitt, NY
(315) 481-4077

salesandservice.cummins.com

Massachusetts Lobstermen's Association Right Whale Litigation Updates

The Massachusetts Lobstermen's Association (MLA) Legal Defense Fund needs your support now more than ever. This dedicated fund is for the purpose of defending the Massachusetts commercial lobster fishermen from legal and fisheries management actions that could seriously impact our commercial lobstermen's ability to conduct their businesses and earn a living.

The MLA is actively engaged in two separate law suits that could have negative impacts on the commercial lobster industry and is working with multiple lawyers in Washington D.C. and here in the Commonwealth to fight for you and your industry. The years of litigation costs have depleted the MLAs' Legal Defense Fund to a critical low point and your help is needed today.

UPDATED FEBRUARY 23, 2022

Case No. 1:18-cv-00112-JEB – Center for Biological Diversity v. Ross et al. (Boasberg, J.) (Federal District Court for the District of Columbia): The MLA counsel filed an Opposition Memorandum in late February. In summary;

[For the reasons stated herein, MALA respectfully requests that this Court enter the order accompanying this memorandum, denying plaintiffs' request for summary judgment. Furthermore, to the extent that this Court finds in favor of Plaintiffs, MALA respectfully requests that any remand instruction be given without vacatur of the 2021 Biological Opinion.]

The Massachusetts Lobstermen's Association will continue to act as an intervenor in this important case, representing the interests of the Massachusetts lobster fishing community.

Civil Action No.: 1:21-cv-01131-TJK – M.S. files a new lawsuit against Michael Pentony, Amy Knowlton, Jane Davenport and Arthur "Sooky" Sawyer in the United States District Court in the District of Columbia. This is almost verbatim the suit filed in Boston in 2020. The MLA counsel has filed a motion to dismiss Sooky from this suit;

[WHEREFORE, the Defendant, Arthur Sawyer, respectfully request this Court grant his Motion and dismiss with prejudice Plain-



tiff's Amended Complaint as to Defendant Sawyer and grant such other relief which is just and equitable.]As we all know, any legal action costs lots of money and the Massachusetts Lobstermen's Association Legal Defense Fund needs your generous support today to continue our fight. These are real threats to the historic and iconic commercial lobster industry and we are doing everything to keep the Massachusetts commercial lobstermen fishing.

WHERE TO MAKE DONATIONS

Any contribution you can afford to make to the Legal Defense Fund is greatly appreciated.

Donate by mail:

MLA LDF,
8 Otis Place
Scituate, MA 02066

Donate online:

www.lobstermen.com

– In the Members section select Dues/Donate.

DONATE TODAY!

to the Massachusetts
Lobstermen's Association
LEGAL DEFENSE FUND

**LEGAL DEFENSE FUND
MARCH 2022**

Matthew Brennan

Michael Russo

Todd Jesse

Therese Sauvageau

Eric Lorentzen

Camden Smith

THANK YOU FOR YOUR CONTINUED SUPPORT!



Donate to the MLA Legal Defense Fund to
“Band the Bite” TODAY!

Help us fill the lobster crate and help relieve
the **“PINCH”** of defending commercial lobstermen!

Let's fill the lobster crate TODAY!

Every \$25 dollars donated puts another lobster in the lobster crate!!

There are several ways to make a donation

MLA website: www.lobstermen.com Legal Defense Fund Donation

Paypal: Legal Defense Fund Donation

Mail or drop off a check:

MLA, 8 Otis Place, Scituate, MA 02066

Call the MLA : 781-545-6984 xt2

Use your camera on your phone to Scan the QR Code

***THANK YOU for YOUR
CONTINUED SUPPORT!***



MLA Classifieds

Classified ads are a free benefit to MLA Members and Non-members are a flat \$25.00. Ads run for 5 months & will be automatically deleted unless you call the MLA office to renew. **781-545-6984** or email ads to: tracey.abboud@lobstermen.com
*All ads are subject to review prior to placement

AD #1 (9/21) **FOR SALE** – Freeman 15 X24 oval hatch. In good shape. \$100.00 401-842-8165. Ted

AD#2 (1/22) **FOR SALE** – 19 2001 Eastern (first year they bought the mold from Seaway); 90 hp Mercury outboard; Hydroslave hauler. Boat custom built. Center console w/canvas top. Center console was built more forward creating more deck space for gear/fishing room. Transom was built higher. Stainless bow rails, fish finder, depth GPS, wash-down pump and Load Rite trailer only a few years old w/ power winch. Live tank & culling table. Boat in great shape. \$16,500. 11 coils of new 5/16 sinking rope. \$2.25 a pound. Coils are 1800 and vary from 40-44 pounds. One coil 5/16 floating line \$2.00 pound. Serious inquiries only. Jack @ 5 p.m. 508-747-5680.

AD#3 (12/21) **FOR SALE** – Hydraulic Components, parts and service. Pumps, Motors, Valves and Accessories. Hydraulic Hoses made while you wait. Great Prices – Same day service (in many cases)- Wide selection of in-stock items. Rebuilt items occasionally available. ROSE MARINE, Gloucester, MA 877-283-3334

AD#4 (12/21) **FOR SALE-Turn-Key Lobster Business-owner retiring:** Area 1 Coastal License-800 Trap Allocation 30 SISU Fiberglass Lobster Boat. New 383 Mercruiser -700 hours. Re-built Borg Warner velvet drive gear-new neck-cut out Stern-New (2) 80-gallon fiberglass fuel tanks-New hydraulics-12 in' hauler-Boat totally re-wired. New Seacocks- 450 traps-good condition/ropes/survival suits. \$70,000 or B.O. Pete 617-653-5012 Leave a message

AD#5 (1/22) **FOR SALE** – 24 Crosley net lift \$2,000.00 11 roller \$600.00 needs some work. Text Only 617-694-4802

AD#6 (3/22) **LOOKING TO BUY** - MA coastal lobster permit- call David @781-775-5569

AD#7 (1/22) **Looking to buy used rope** – located in Sandwich MA-will

pick up on Cape Cod & South Shore. E-mail lobstermats@gmail.com or 617-275-3744

AD#8 (10/21) **FOR SALE** – 1 roll of black 10-gauge repair wire 2inch\$225.00 Mark- 508-843-8614

AD#9 (3/22) **FOR SALE** – Lobster Fishing Gear-Used ground lines 7/16-20 Pot Trawls 15fm-17fm, spacing-3/8, gangings-50 fm end lines. Everson-EsterPro & Hoover Alison. All spliced in 50 gallon drums. \$125 per Drum- call Mike 603-431-8174

AD#10 (2/22) **FOR SALE** – Twin Disc MG506 1A 1.54:1 ratio running takeout, spun tested. \$3000 Steve 978-257-1062

AD#11 (12/21) **ATTENTION C-TRAP CUSTOMERS/GOT WOOD** - New wooden conch traps for sale, many types, prices starting @ \$23.50ea for 20x20 all oak frames 3 wide pine lath sides. Will cut custom lobster traps/frames/runners/ laths. 508-989-4762

AD#12 (12/21) **FOR SALE** - MA state coastal lobster permit, Area 1. \$28,000.00 Call 339-927-6972

AD#13 (2/22) **FOR SALE** - Warp –Used & some new, mostly knot free. 76 lbs. 5/16, 33 lbs. 3/18 \$99.00 takes all. 508-269-1406 Plymouth

AD#14 (10/21) **FOR SALE** – Massachusetts State Lobster Permit, Area 1 \$27,500 781-639-0001

AD#15 (10/21) **FOR SALE -PRICED REDUCED** – 1977 Robert Rich 36. John Deere 6076 300hp., ZF 280A 1.9:1 gear. Major overhaul 4 years ago. Rebuilt gunwales and glassed over wash rails and trunk cabin. Aluminum fuel tanks, new floor framing, transom cut out framed in stainless, IPE deck (black ironwood). \$30,000 – 781-534-3214

AD#16 (1/22) **FOR SALE** – Bronze dual ram steering quadrant-Freeman Oval hatch- 15x23 opening+ SS longline rail roller- and SS crucifier. SS mast base. 2 2ft., outriggers-no base-PC Winplot complete chart plotting program with monitor, computer, Furuno GPS and all

support items needed. Mike 978-745-6182 leave message

AD#17 (10/21) **LOOKING FOR** – Scallop wench for a 32-35 footer possibly A-frames. Andrew Whiden 603-404-4785

AD#18 (12/21) **FOR SALE** - Cab for pickup truck w/ 8 ft bed. No damage, Black w/ windows. \$50.00 B.O. Phil 617-429-2956

AD#19 (1/22) **FOR SALE** –26ft Lobster Boat, Atwood-Novi 10 1/2 ft. beam, flat bottom. 90 Honda H.P. hydraulic hauler, good shape-asking \$8,500.00 – 781-375-6409

AD#20 (2/22) **FOR SALE** - Gillnet gear, 24 Crosley lifter, all hardware to mount, picking table /spreader \$900.00 6 insulated vats \$50.00 ea. 8 pingers \$30.00 ea. 40 round-fish nets, 40 monk fish & 11 new webs all \$45.00 ea. Call/text 774-264-0083

AD#21 (2/22) **FOR SALE** - MA Coastal Lobster Permit Area 1 \$28,000.00-978-273-3168

AD#22 (1/22) **FOR SALE** - Newly Restored H&H 32. Cummins 210 6bta about 7000 hrs twin disc transmission. Installed new turbocharger on engine. Custom stern extension & davit put on last year. new wiring & electronics & much more. Comes W/ lots of extras. \$70,000 or (BRO). 508-360-6318

AD#23 (11/21) **FOR SALE** - MA State Lobster License, Area 1, 800 pot allocation. \$27,500.00. 978-335-5860.

AD#24 (11/21) **FOR SALE** - 2000 Mitchell Cove 32ft. Good hull, electronics, hydraulics. J.D. 225 HP 22,000 hours -needs re-build. Federal non-trap lobster, MA conch, scup permits. 150 conch traps,17 scup traps, rope, buoy's, 1,000 hooks new tub trawl-gear & all spare equipment. Will separate. Owner retiring. B.R.O. Bryan @ 508-221-8568

AD#25 (11/21) **FOR SALE** - 4-blade right-hand propeller 32x24x4 2 1/2 inch \$1,000.00 631-665-1677

AD#26 (12/21) **FOR SALE** - 34 J. Ervin Jones 1978, 1 Mahogany on Oak (re-fast 2004) 3208TA CAT 507 twin disc direct drive clutch, spare prop Furuno 1623 Radar Furuno FVC 620 Sounder Furuno, GPS 32 standard horizon chart plotter, ICOM VHF. MA Area 1 lobster permit, 800 allocation, 500- traps w/ ropes & buoys, 14 skiff w/outboard, clip gun cutting tool. \$60,000.00 BRO Call Les before 8p.m. 508-364-6926

AD#27 (1/22) **FOR SALE** - The NOVE-purchased from original owner in Portland ME & currently owned by (2nd owner) past 3 years & has grown to be a great part of our family-year-round. Nove very versatile & comfortable. Excellent for cruising & uses little fuel, has hauler & davit for lobstering, multiple rod holders for fishing. The aft deck can seat 4-6 Adirondack chairs comfortably, main cabin-dining table-seats 4 comfortably & converts to a bed-sleeps 2. Fore cabin has exceptionally large v-berth could be compared w/a king-size bed. The Portside-full-size storage closet, head, shower & sinks w/ mirror, etc. The Starboard side-expansive cabinets w/sink, microwave & bar. Wooden hull (Pine planks over white Oak frame) Dry weight 17,000 lbs, Teak trim, fiberglass deck & house, Hydraulic steering, 2 100-gal; water tanks, 2 100-gal; fuel tanks, Fore Cabin head/bed/sink/microwave/storage, Keel cooler setup for Engine, Autopilot-ITEMS REPLACED-2018, Cummins Diesel Engine -6 cylinder 6BT T1 M@2600rpm R KC (100 hours) Rebuilt transmission (2019) propeller, exhaust. \$39,500 Brandon-978-465-3022

AD#28 (2/22) **FOR SALE** - LMA-1 Federal lobster permit, 800 trap allocation, good history, \$38,000.00 978-578-8882

AD#29 (3/22) **LOOKING FOR** - Area 1 coastal lobster permit. 339-788-3621

AD#30 (3/22) **FOR SALE** - 50 Riverdale Green trap kits. \$30.00 each 60" x 36" w/tabs 16-1/2" x 33" door 19-1/2" x 22-1/2" 12.5G rear panel 19-1/2" x 22-1/2" 10 G front panel TXT 978-821-3499

CAT MARINE ENGINES

Tier 3 Commercial Line-up

C7.1



C7.1 Tier 3 Commercial Ratings:

280 HP @ 2300 Heavy Duty "B" **IN STOCK**
350 HP @ 2500 Maximum Continuous Duty "C" **IN STOCK**
400 HP @ 2600 Intermittent Duty "D" **IN STOCK**
425 HP @ 2700 Intermittent Duty "D" **IN STOCK**

C9.3



C9.3 Tier 3 Commercial Ratings:

375 HP @ 1800 Heavy Duty "B"
416 HP @ 2100 Maximum Continuous Duty "C"
476 HP @ 2300 Intermittent Duty "D"

C18



C18 Tier 3 Commercial Ratings:

470 HP @ 1800 Continuous Duty "A"
600 HP @ 1800 Continuous Duty "A"
670 HP @ 1800-2100 Heavy Duty "B"
715 HP @ 1800-2100 Maximum Continuous Duty "C"
803 HP @ 2100 Intermittent Duty "D"

* Tier 4 Exempt Light Commercial Ratings:

1,001 BHP @ 2300
1,136 BHP @ 2300

C32



C32 Tier 3 Commercial Ratings:

750 BHP @ 1600-1800
800 BHP @ 1600-1800

AUTHORIZED MARINE DEALERS

Billings Diesel & Marine Service

Stonington, ME

Dennis' Welding & Marine

Beals, ME

Front Street Shipyard

Belfast, ME

Lyman Morse at Wafarer Marine Corporation

Camden, ME

Journey's End

Rockland, ME

Fairhaven Shipyard & Marina, Inc.

Fairhaven, MA

Guy Crudele Repair

Gloucester, MA

Sacchetti Marine and Industrial LLC

Plymouth, MA

Windward Power Systems

Fairhaven, MA

DePaul Diesel Services, Inc.

Portsmouth, RI

Hinckley Yacht Service

Portsmouth, RI

Rhode Island Engine Company, Inc.

Narragansett, RI

*All T4 Exempt Light Commercial Ratings, require qualifications review and approval by CAT Factory.

*Contact Nick Fawle or Your Authorized Marine Dealer for Tier 4 exemption qualification details.

For Marine Engine Sales, contact Nick Fawle, our new Marine Market Manager.

Nick Fawle at 603-484-5248

Nick_Fawle@miltoncat.com

Milton



miltoncat.com

Massachusetts Lobstermen's Association
8 Otis Place
Scituate, MA 02066

PRSR STD
U.S. POSTAGE
PAID
Permit 137
New England Newspapers, Inc.



**Stock and Custom-Built Traps
Lobster and Specialty Traps
Aquaculture Supplies
Huge Inventory of Commercial
Fishing Supplies
Four Locations in Maine**



**BROOKSTRAPMILL.COM
(800) 426-4526**