



# MASSACHUSETTS LOBSTERMEN'S ASSOCIATION



JOIN TODAY and show your support

A LEADING Commercial Fishing Industry Association in New England

FEBRUARY 2020 NEWSPAPER • WWW.LOBSTERMEN.COM



MLA Annual Weekend  
PG 14



ASMFC Update  
PG 25



DMF Meeting  
PG 37



## NOAA Right Whale Regulations are in Process .....

As the National and Oceanic and Atmospheric Administration (NOAA) continues on with their rule making process for the conservation of right whales there has been a lot of push back from the commercial lobster industry in the Northeast. The commercial lobster industry representatives up and down the coast have been talking and working with Greater Atlantic Regional Fisheries Office

(GARFO/NMFS) representatives on how to improve the data currently being used to determine what percentage of conservation each state is responsible to achieve.

Many of you have been following what is going in Maine from; Maine's consensus withdrawal from the proposed endline reduction targets from the Atlantic Large Whale

### YOU CAN NOW FOLLOW THE MLA ON THE FOLLOWING SOCIAL MEDIAS



#### FACEBOOK

[www.facebook.com/mass.lobstermensassoc](http://www.facebook.com/mass.lobstermensassoc)

If we are not already friends on FB and you want to be please send a message as we are at the 5000 limit and we will always make room for MLA members.



#### TWITTER

[www.twitter.com/masslobstermens](http://www.twitter.com/masslobstermens)

If you tweet and want to follow the MLA this is a great way to stay up to date with all kinds of fisheries related news.



#### YOUTUBE

<http://www.youtube.com/user/lobsterdiva>

If you have any videos of fishing you would like to share please send them along. The MLA this has the camera rolling with all kinds of fisheries related news videos. Take a look!



#### PINTREST

<http://pinterest.com/masslobsters/>

Yes, now the MLA is Pinning to the wall! Take a look at Pinterest—this is the latest and hottest social media out there for sharing information. We Book, Tweet, Tube and now Pin!



#### Massachusetts Lobstermen's Association App now available

Yes, now the MLA has an app for Apple I Phones and I Pads for FREE. When searching your app store spell MLA out. Keep up to date with all of the latest industry issues and other great tools. We Book, Tweet, Tube, Pin and now we have an App to keep you connected!



#### Massachusetts Lobstermen's Association App now available

Yes, now the MLA has an app for Android Phones and Tablets for FREE. When searching your app store spell MLA out. Keep up to date with all of the latest industry issues and other great tools. We Book, Tweet, Tube, Pin and now we have an App to keep you connected!

# COVER STORY

Take Reduction Team (TRT) meeting last year to the recent endline reduction proposal submitted by the Maine Department of Marine Resources on December 27, 2019.

You may be asking yourself, “Why hasn’t the Massachusetts Division of Marine Fisheries (DMF) submitted anything yet?” or “Why aren’t there any meetings being held in Massachusetts about the reductions?” The long and short of it is that GARFO/NMFS has not resolved the uncertainty on a number of issues that are critical to understanding the landscape of forthcoming regulations. These include; how much risk reduction credit is going to be given for a “weak link” or “weak contrivance”, the need for a potential seasonal closure in the offshore Gulf of Maine, and the need for, size, and timing of a closure south of Nantucket in LMA2. You got it, this has thrown a BIG monkey wrench into the rule making process.

The MLA has been in close contact with GARFO/NMFS and the DMF throughout the right whale rule making process to monitor and evade inequitable allocations of conservation reductions between the states. The DMF has

been very clear in its messaging, to anyone who asks, that until they see what is proposed by Maine and accepted by NOAA they cannot recommend anymore conservation measures as Massachusetts is currently doing more than other state. Once DMF has a clear picture of what is going to be required and how much credit will be given for different options it plans to hold meetings with MA fishermen.

Provided that a 60% risk reduction is required for all jurisdictions, Massachusetts LMA1 and LMAOCC could achieve this with the Massachusetts Bay Restricted Area and the implementation of a 1,700lb weak link or “weak contrivance”. In LMA2 risk reduction will be achieved with credit for ongoing trap reductions, the implementation of 1,700 lb weak links, and newly added to the menu is the possibility of a closure south of Nantucket (details yet to be determined).

Currently, there is not definition or understanding of what is a “weak contrivance” even as GARFO/NMFS is working on developing a list of acceptable “weak contrivances”. The Lobster Foundation of Massachusetts is currently working on developing several 1700lb 3/8” endlines that could be included on the list of acceptable

*continued on page 26*



**Published by the Mass. Lobstermen's Assoc., Inc.**  
**8 Otis Place**  
**Scituate, MA 02066**

**Published monthly**

Mailed to all paid members of the Massachusetts Lobstermen's Association

**Newsletter Departments**

*Editor, Industry News, Notice Section, Editorial, Blog, Industry News, Promotions, Layout, Advertising:* Beth Casoni — Executive Director

Billing: Elaine Kracov

Buy Sell Swap: Tracey Abboud

**Newsletter Advertising Rates**

The MLA Newsletter is published monthly

(Please note that all pre-paid ads for last year will be honored)

\$35 — ¼ Page Ad

\$65 — ½ Page Ad

\$95 — Full Page Ad

Color Ads — + \$25 per ad

## “NEW” MLA LOBSTER GEAR

Call 781-545-6984 or visit [www.lobstermen.com](http://www.lobstermen.com)



**Working to maintain a sustainable resource in the marine ecosystem.**



**Individuals can help this cause by becoming a Supporting Member.**

**8 Otis Place**  
**Scituate, MA 02066**  
**781.545.6984**



For more information, visit our website [www.lobstermen.com](http://www.lobstermen.com)



# SPONSOR LIST

THE FOLLOWING COMPANIES ARE PROUD SUPPORTING MLA MEMBERS.  
WE ENCOURAGE OUR MEMBERS TO PATRONIZE THEM. IF YOUR COMPANY IS NOT LISTED AND YOU WOULD LIKE IT TO BE,  
PLEASE CONTACT TRACEY ABOUD AT 781-545-6984 ext. 2

## ALIVE & KICKING LOBSTER

LOUIS MASTRANGELO  
CAMBRIDGE, MA  
617-876-0451

## ARK BAIT

FRESH/SALTED  
MENHADEN BAIT  
508-678-4161

## BAR HARBOR LOBSTER

JEFF HAZELL  
ORLANDO, FL  
407-851-4001

## BESSY BAIT

SCOOTER BAKER  
SEABROOK, NH  
603-300-2849

## BOB LOBSTER

(FISH MKT & LOBSTER  
POUND)  
ROBERT HARTIGAN  
PLUM ISLAND, MA  
978-465-7100

## BOSTON LOBSTER

Lobster Dealer  
NEIL ZARELLA  
617-464-1500  
www.bostonlobstercompany.com

## BOSTON SWORD & TUNA

STEPHEN SCOLA  
Boston, MA  
617.946.9850

## BROOKS TRAP MILL

STEPHEN BROOKS  
THOMASTON, ME  
207-354-8763  
stephen@brookstrapmill.com

## CAPE ANN MARINE

SALES & SERVICE  
978-283-0806  
CapeAnnMarina.com

## C-TRAP

MATT BORGES  
MATTAPOISETT, MA  
508-758-2470

## CAPE COD CLAM & SEAFOOD

SO. CHATHAM  
CURT COLLINS  
508-246-4366

## CAPE CODDER MARINE, LLC

BOB DOBIAS  
Swampscott, MA  
978-979-1795  
www.capecodderboats.com

## CAPE SEAFOODS BAIT DEALER

GERRY O'NEIL  
GLOUCESTER  
978-479-4642

## CAPE FISHERMEN SUPPLY

DAVE LIBBY  
CHATHAM, MA  
508-945-3501

## CAPE TIP SEAFOODS

CHRIS KING  
PROVINCETOWN  
508-487-0259

## CAPE TIP SEAFOODS

CHRIS KING  
ORLEANS  
508-255-7221

## CAPTAIN MARDEN'S

SEAFOODS  
WELLESLEY, MA  
KIM MARDEN  
781-329-7007  
781-329-0792  
www.captainmardens.com

## CHERRY ST. FISH MARKET

DANVERS, MA  
DARRYL PARKER  
978-777-3449

## CHRIS ELECTRONICS CORP.

255 MacArthur Drive  
New Bedford, MA  
508-994-8257

## COASTAL HYDRAULICS

RICH TUCKER  
SEABROOK, NH  
603-474-1914  
www.coastalhyd.com  
sales@coastalhyd.com

## COHASETT LOBSTER

POUND  
TOMMY ALIOTO  
COHASETT, MA  
781-383-1551

## COMMERCIAL MARINE ELEC

DANIEL HODGKINS  
SCITUATE, MA  
781-545-7883  
www.comercialmarine.net

## WILL COLLINS

Marine Sales Manager  
Cummins Sales/Service  
Office 781-801-1772  
Cell 401-339-4004  
will.collins@cummins.com

## DOLE & BAILEY

SPENCER MONTGOMERY  
WOBURN, MA  
781-935-1234  
www.doleandbailey.com  
www.northeastoceans.com

## EAST COAST SEAFOOD

LYNN, MA  
SPIROS TOURKAKIS  
781-593-1737

## ELECTRA-DYNE CO INC.

JUDY MACCAFERRI  
PLYMOUTH, MA  
508-746-3270

## FARM CREDIT EAST

MIDDLEBORO, MA  
508-946-4455

## FISHER AIR FASTENERS

ED & CHRIS FISHER  
PEMBROKE, MA  
781-826-2522

## FISHERMEN SERVICES

Donna Chepren & Elaine  
Kracov  
781-545-5073  
www.fishermenservices.com

## FRIENDSHIP TRAP CO.

CHRIS ANDERSON  
FRIENDSHIP, ME  
800-451-1200

## GRUNDENS USA

MICHAEL JACKSON  
POULSBO, WA  
360-779-4439  
www.grundens.com

## HAMILTON MARINE INC.

800-639-2715  
Hamiltonmarine.com

## JAMES HOOK & CO.

ED HOOK JR.  
BOSTON, MA  
617-423-5500

## INDUSTRIAL MARINE MKTG.

ROGER SMITH  
WAKEFIELD, RI  
401-782-4412

## HERCULES

JOHN REARDON  
NEW BEDFORD MA  
508-993-0010

## JOLIN LOBSTER

MANCHESTER, MA  
GEOFFREY SONES  
TEL 978-526-7954 / FAX  
978-526-7609

## JOHN M. KARBOTT CUSTOM WOODEN BOAT BUILDING & REPAIR

PLYMOUTH, MA  
508-224-3709  
www.by-the-sea.com/  
karbottboatbuilding

## KETCHAM TRAPS

ROBERT KETCHAM  
NEW BEDFORD, MA  
508-997-4787

## KINGFISHER TRAP

CARL HOWARD  
DENNIS, MA  
508-385-5968

## KING LOBSTERS

D.J. KING  
BRANFORD, CT  
203-488-6926

## KING MARINE LLC

CAPT. GEORRDIE KING  
MARINE SURVEYOR  
207-337-8706  
kinggeordie@comcast.net

## Life Raft & Survival Equipment Inc

590 Fish Road  
Tiverton, RI 02878  
Main Office 401-816-5400  
Fax 401-816-5411  
Web www.lrse.com

## LOBSTER CRUISES

PAUL QUINTAL  
PLYMOUTH, MA  
508-746-5342

## LOBSTER TRAP FISH MARKET

MONUMET BEACH, MA  
508-759-6400  
WWW.LOBSTERTRAP.COM

## LOBSTER TRAP CO.

LOGAN CLARK  
BOURNE, MA  
508-759-4928  
www.lobstertrap.com

## LYNCH LOBSTER CO

JOHN LYNCH  
BEVERLY, MA  
978-921-8088

## MANCHESTER LOBSTER

TONY REZZA  
MANCHESTER, MA  
508-932-0990

## MARINE PROPELLER SERVICE

MIKE VALM  
NEW BEDFORD, MA  
508-979-8000

## MARINE HYDRAULIC ENGINEERING

ROBERT CROWE  
ROCKLAND, ME  
207-594-9525  
1-800-747-7550

## MILTON CAT POWER SYSTEMS

KEVIN HAMPSON  
MILFORD MA 01757  
508-207-8542

## MORTILLARO LOBSTER, INC.

VINCE MORTILLARO  
GLOUCESTER, MA  
798-281-0959

SPONSORS *Continued from page 3*

## How are you feeling today?

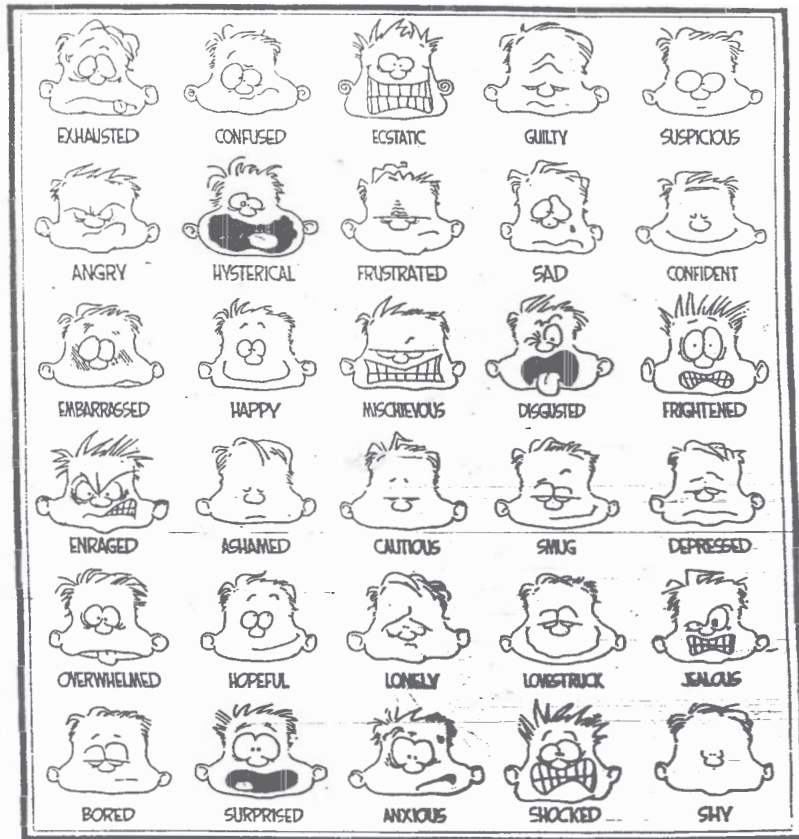

**NAUSET FISH & LOBSTER POOL**

ORLEANS, MA  
REBECCA HARRISON  
508-255-1019

**NEW ENGLAND BOATING**

508-789-6708  
tom@lighthousemags.com

**NEW ENGLAND CRAB COMPANY**

BOSTON, MA  
MARK NEWBERT  
617-464-1999

**N.E. MARINE & INDUSTRIAL INC.**

MIKE RICHARDSON (NH)  
603-436-2836  
781-834-9301 Info@  
newenglandmarine.com

**THE NET RESULT**

LOUIS LARSEN  
MARTHA'S VINEYARD  
Mvseafood@vineyard.net

**NEW ENGLAND PROPELLER**

RON PECK  
PLYMOUTH, MA  
800-635-9504  
neprop@aol.com

**NORTH ATLANTIC POWER**

TWIN DISC ~ SAM PROFIO  
EXETER, NH  
sprofio@glpower.com  
603-418-0470

**NORTHEAST TRAP LLC**

Michael Christian / Peter Christian  
Douglas, Ma  
508.294.6999  
northeasttrap@verizon.net

**OCEAN STATE LOBSTER**

KEVIN BATES  
NARRAGANSETT, RI  
401-782-3500

**PENDER MARINE SERVICES**

PAUL PENDER  
WESTWOOD, MA  
617-240-1622

**RFP LOBSTER BAIT**

DICK PERENTZ  
774-248-0292

**RIVERDALE MILLS**

NORTHBRIDGE, MA  
508-234-8715

**ROWAND FISHERIES**

DANA ROWAND  
2 CABOT ST.  
BEVERLY MA 01915  
978-927-1871

**ROSES MARINE**

MARTY BOLCOMBE  
GLOUCESTER, MA  
877-283-3334  
www.rosesmarine.com

**SANDWICH SHIP SUPPLY**

DON SPRING  
SANDWICH, MA  
508-888-0200

**SEA CLIFF LOBSTER**

FRANK COLLINS  
MANOMET, MA  
508-224-5700

**SILVER KEY, INC.**

WESTPORT, MA  
CHUCK HUSKINS  
508-673-3310

**The Massachusetts Lobstermen's Association** would like to welcome the following new members to the Association. Your Association will continue its efforts on your behalf to conserve the resource, protect your livelihood, keep you informed, promote the industry and provide you with increasing benefits as they are developed. MLA stands ready to help you in anyway, at anytime — just let us know how!

*Safe on the water and good fishing!*

New Members	F/V Name	Port	Company
Paul E Hunt	Joane E	Hull	Nahant Fish & Lobster
Peter Rogal			

**SPURS MARINE Mfg**

PABLO SOSA  
FORT LAUDERDALE, FL  
800-824-5372

**SUPERIOR LOBSTER**

DARRYL DURNFORD  
HUMAROCK, MA  
774-773-5048

**W.B. VAN DUZER CO.**

WILLIAN VAN DUZER  
DUXBURY, MA  
781-585-7664

**TWO COUSINS FISH MARKET**

BRIAN O'DONOHUE  
FREEPORT, NY  
516-379-5065

**Wellfleet Shellfish Co.**

Alex Hay  
508-255-5300  
sales@wellfleetshell.com

**WINDWARD POWER SYSTEMS**

JIM & NATE TYNAN  
FAIRHAVEN, MA 774-992-0059  
www.windwardpower.com

**WOOD'S SEAFOOD**

PLYMOUTH, MA 02360  
508-746-0261

**YANKEE FISHERMEN'S CO-OP.**

SEABROOK, NH  
603-474-9850

# Calendar of Events

## FEBRUARY

2/4 -6 Atlantic State Marine Fisheries Commission, The Westin Crystal City, 1800 S.Eads Street, Arlington VA 22202

2/12 MLA Delegates meeting- Sons of Italy Hall 120 Quarry St Quincy, MA 02169 7:00pm

2/14 Happy Valentines Day!  
Don't forget your sweetheart!

2/17 Presidents Day! MLA and Fish offices are closed

## MARCH

3/17 Happy St Patricks Day!

3/18 MLA Delegates Meeting- Sons of Italy Hall 120 Quarry St Quincy, MA 02169 7:00pm

3/25 MFAC Business meeting - DFW's Headquarters, 1 Rabbit Hill Rd Westborough, MA 01581 9:00am-2:00pm

*Please check the MLA website for more meetings and events as they will be added.*

## APRIL

4/17 to 4/19 MLA Annual Weekend Industry Trade Show - Resort and Conference Center at Hyannis 35 Scudder Ave, MA 02601.

*Rooms are filling up fast - Don't delay and book your room today! All reservation forms can be found here [www.lobstermen.com](http://www.lobstermen.com)*

4/18 MLAs Annual Membership meeting will be held during the Annual Weekend (Time TBD)



# LIFERAFT SERVICES

MARINE SAFETY AND SURVIVAL EQUIPMENT

## 5% DISCOUNT ON SERVICE FOR MLA MEMBERS!

- LIFERAFT INSPECTIONS

- EPIRBs & PLBs

- SIGNALING DEVICES

- IMMERSION SUITS & PFDs

- PICKUP & DELIVERY



[www.SURVIVALATSEA.com](http://www.SURVIVALATSEA.com)

# 207.363.0220



## NEW ENGLAND PROPELLER, INC

MARINE PROPELLER SPECIALISTS

TOLL FREE 1-800-635-9504

9 APOLLO ELEVEN ROAD • PLYMOUTH INDUSTRIAL PARK • PLYMOUTH, MA 02360

TEL (508) 747-6666 • FAX (508) 746-8804

WWW.NEPROP.COM • NEPROP@AOL.COM

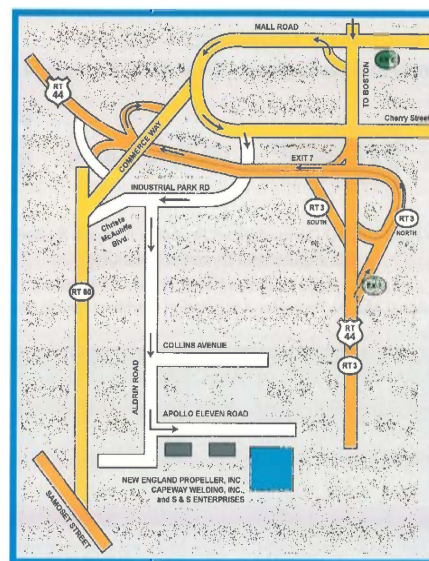

CALL FOR DROP OFF LOCATIONS OUTSIDE OF PLYMOUTH AREA

NEW ENGLAND PROPELLER, INC  
MARINE PROPELLER SPECIALISTS

### M.L.A. COUPON

**10% Off**  
Propeller Repairs

Any Size, Any Style • When You Need It Fast  
Quality Affordable Repairs

*Redeemable only at New England Propeller*

NEW ENGLAND PROPELLER, INC  
MARINE PROPELLER SPECIALISTS

### M.L.A. COUPON

**15% Off**  
Inboard Propellers Class 1 Hale M.R.I.  
with Analysis Reports

**15% Off**  
Dynamic Balancing

*Redeemable only at New England Propeller*



*Service Provider for MLA Non-Profit Boat Protection Cooperative Ltd.*

**MLA's #1 Commercial Boating Insurance Provider**

- **Agreed Hull Value – Protection & Indemnity**
- **Crew Coverage - Extended Policy Limits - Chartering**
- **Marina Floaters - Multiple Fisheries & Deductibles**

**Call 781-545-5073 for a free quote or**

**request a quote online at [fishermenservices.com](http://fishermenservices.com)**



# As the HAULER TURNS



After a mild start to 2020 let's hope February doesn't come in with a wintery wallop. I know that I am all set with shoveling snow and dealing with the nuances of winter. Despite the fact that the weather has been mild so far this winter there seems to be a flurry of industry habitat, wind and whale related meetings that have been held and forthcoming. All of these topics will impact the fisheries collectively and while some of these topics processes are long and drawn-out your participation is requested. The MLA has and will continue to be in attendance at all associated meetings to voice concerns and submit written comments accordingly.

Last month, the New England Fisheries Management Council (NEFMC) Habitat Committee and Advisory Panel met to discuss and review the; NEFMC annual research priorities related to habitat, develop comments on the Coonamessett Farm Foundation Essential Fishing Permit, offshore wind briefing, update on development of habitat policies for aquaculture, submarine cables, and floating wind, and an update on the Northeast Regional Habitat Assessment. Recently I was reappointed to a 3 year term to sit on the Habitat Advisory Panel and this will be my third term. If you are interested in participating the NEFMC is always looking for industry representatives. The Habitat Committee and Advisory Panel meeting summary is in this newspaper for your review.

For all of you who have been participating and following the Southern New England offshore wind development process please be advised that there is an upcoming Coastal Resources Management Council Fishermen's Advisory Board meeting on Monday, February 10,

2020, 5:00 p.m., at the URI Coastal Institute – Hazard Conference Room 215 South Ferry Rd, Narragansett, RI. The items to be discussed will cover a description of Ørsted's New England projects with a brief summary of current project status; and the South Fork Wind Farm update on project layout in revised COP and fisheries data collection sciences. (Meeting notice on pg 40 in this newspaper)

Recently, the Massachusetts Division of Marine Fisheries (DMF) announced that they will be hosting two Scoping Meetings on the States Response to Anticipated Changes to Federal Atlantic Large Whale Take Reduction Plan Affecting Trap Fisheries. Please plan on attending these meetings as the DMF will be discussing the state's response to anticipated changes to the federal Atlantic Large Whale Take Reduction Plan and will be looking for your input.

The DMF meeting schedule is on pg 10 in this newspaper and dates are as follows:

**6PM, February 18, 2020, Admiral's Hall, MA Maritime Academy, 101 Academy Drive, Buzzard's Bay, MA 02532**

**6PM, February 19, 2020, DMF's, Annisquam River Field Station  
30 Emerson Avenue, Gloucester, MA 01930**

As many of you have been asking, "What is Massachusetts doing?" in response to the whale rule making process, this is the time to come and hear it directly from the State and not leave anything to hearsay or dock talk. The MLA will also be hosting the DMF at its upcoming February 12th Delegates meeting to discuss all things whale and "weak contrivance" related.

There is no denying that the right whales are off the coast of Massachusetts from February 1st to April 30th, as the 3071 square mile, 3 month MA Restricted Area Closure has been in place for over 5 years now, but where do they go the rest of the year and how do they get there? As my predecessor, Bill Adler, used to say "They must take the Acela to the Gulf of St. Lawrence", he was right! Not knowing where these animals are the other nine months of the year leaves one wondering, does anyone really care about them when they are NOT off the coast of Massachusetts or is it just easier to see them in Massachusetts?

The MLA will continue to request more monitoring and the tagging of these animals so to better understand where they go and when so suitable conservation measures are implemented, if we can put a microchip in a dog, why not a right whale? Massachusetts lobstermen have been bearing the brunt of right whale conservation for over 30 years now and they are still dying, in Canada. Enough is enough! I look forward to seeing you at the DMF Scoping meetings.

*Safe on the water, Beth Casoni, Executive Director*

Massachusetts Lobstermen's Association  
8 Otis Place  
Scituate, MA 02066

Office 781-545-6984  
Fax 781-545-7837  
[www.lobstermen.com](http://www.lobstermen.com)

**MEMBERSHIP APPLICATION**

<b>TYPE OF MEMBERSHIP</b>	<b>Full Voting</b>	<b>Associate</b>	<b>Business</b>
	<b>\$150 Annual Dues</b>	<b>\$150 Annual Dues</b>	<b>\$250 Annual Dues</b>

\*To qualify for a Full Regular Membership, you **MUST** (1) hold a valid Mass. Commercial Lobster License, (2) reside in Massachusetts, (3) be sponsored by either two Regular Members or one Delegate, and (4) send in a copy of your lobster license with this application.

**Sponsors:**

#1 Name \_\_\_\_\_ [ ] Delegate [ ] Regular Member

#2 Name \_\_\_\_\_ [ ] Delegate [ ] Regular Member

**Name**

**Business Name** \* Business members will now be listed in 2"x2" ad in the new MLA business section at the front of the monthly newspaper, a 2"x2" ad linked to your website will be added to the MLA website, preferential ad location selection in the newspaper and early registration and booth preferences for the MLA Annual Weekend event.

**Address**

**City/Town** **State** **Zip Code**

**Home Phone** **Cell Phone** **Work Phone** **Fax Number**

**Email Address** **Website**

**Vessel Name** **Homeport** **Permit ID#** **Type of Permit**

Check here if you would like Hull and P&I Insurance information sent to you

**Payment options – Cash, Check, Master Card or Visa**

**Credit Card Number** **Exp. Date** **3 digit security#** **Zip code**

**Signature** \_\_\_\_\_ **Date:** \_\_\_\_/\_\_\_\_/\_\_\_\_



# REPOWER your boat with a new Cummins diesel engine.



**QSB6.7**  
250-480 HP



**QSC8.3**  
500 HP



**QSL9**  
290-410 HP



**QSM11**  
610 HP

**Contact your local Cummins distributor or dealer for complete program details.**

**Steve Nadeau** - MA, ME, RI and Upstate NY  
207-510-2247 | [steve.nadeau@cummins.com](mailto:steve.nadeau@cummins.com)

**Will Collins** - MA, RI, CT and NY  
781-801-1772 | [will.collins@cummins.com](mailto:will.collins@cummins.com)

## NETWORK OF MARINE ENGINE DEALERS THROUGHOUT NEW ENGLAND

**Billings Diesel and Marine**  
Stonington, ME  
(207) 367-2328

**Brewers' Plymouth Marine**  
Plymouth, MA  
(508) 746-4500

**Brewer Greenwich Bay**  
Warwick, RI  
(401) 884-0544

**Bristol Marine**  
Bristol, RI  
(401) 253-2200

**Cape Ann Marine**  
Gloucester, MA  
(978) 283-2116

**Casco Bay Diesel**  
Portland, ME  
(207) 878-9377

**Great Island Boat Yard**  
Harpwell, ME  
207-729-1639

**Great Bay Marine**  
Newington, NH  
603-436-5299

**Gorham's Diesel Repair, Inc.**  
Braintree, MA  
(781) 843-0816

**Hinckley Yacht Services**  
Portsmouth, RI  
(401) 683-7100

**Hinckley Yacht Services**  
Southwest Harbor, ME  
(207) 244-5572

**Hodgdon Yacht Services**  
Southport, ME  
(207) 633-2970

**Hyannis Marina**  
Hyannis, MA  
(508) 775-5662

**Independent Field Service**  
Dewitt, NY  
(315) 481-4077

**James Rich Boat Yard**  
Southwest Harbor, ME  
(207) 244-3208

**Journey's End Marina**  
Rockland, ME  
(207) 594-4444

**Kennedy Marine  
Engineering & Fabrication**  
Steuben, ME  
(207) 546-7139

**Kingman Yacht Center**  
Cataumet, MA  
(508) 563-7136

**MacDougall's Cape Cod  
Marine Service**  
Falmouth, MA  
(508) 548-3146

**Merri-Mar Yacht Basin**  
Newburyport, MA  
(978) 465-3022

**Niemiec Marine**  
New Bedford, MA  
(508) 997-7390

**Point Judith Marina**  
Wakefield, RI  
(401) 789-7189

**Port Niantic Inc**  
Niantic (East Lyme), CT  
(860) 739-2155

**Rhode Island  
Engine Co., Inc.**  
Narragansett, RI  
(401) 789-1021

**Russ Marine Service**  
Peabody, MA  
(978) 532-3373

[salesandservice.cummins.com](http://salesandservice.cummins.com)



**FOR IMMEDIATE RELEASE** PRESS CONTACT: Janice Plante, [jplante@nefmc.org](mailto:jplante@nefmc.org)  
 January 29, 2020 PRESS CONTACT: Mary Sabo, [msabo@mafmc.org](mailto:msabo@mafmc.org)

## Councils Approve Omnibus Commercial eVTR Framework

The New England Fishery Management Council and the Mid-Atlantic Fishery Management Council have taken final action on an omnibus framework adjustment that will require commercial fishermen to submit vessel trip reports (VTRs) electronically as eVTRs instead of on paper for all species managed by both Councils. The Mid-Atlantic Council initiated the action in December of 2018 and signed off on the framework during its December 2019 meeting. The New England Council joined the framework in June of 2019 and took final action during its late-January 2020 meeting in Portsmouth, NH.

Once approved and implemented by the Greater Atlantic Regional Fisheries Office (GARFO) of the National Marine Fisheries Service (NMFS/NOAA Fisheries), the framework will:

- Require commercial vessels with federal permits for all species managed by both Councils to submit currently required VTRs to NOAA Fisheries through electronic means; and
- Change the VTR reporting deadline to 48 hours after entering port at the conclusion of the trip.

This action does not change any other existing requirements associated with VTRs but would be an administrative modification in the method and timing for submitting these reports.

The vast majority of fishermen currently submit VTRs on paper even though the option to submit vessel trip reports electronically has been available since 2013. NMFS is aware that the learning curve will be steep, and the agency already has indicated that a final rule would include an extended implementation deadline of up to a year to allow for

### Number of Commercial eVTRs Submitted in 2018

Paper	73, 132
Electronic	7,727

*The above VTR numbers were reported by GARFO for vessels issued a commercial permit in 2018 for New England or Mid-Atlantic Council-managed species.*

New England Fishery Management Council Affected Stocks / Management Plans	Mid-Atlantic Fishery Management Council Affected Stocks / Management Plans
<ul style="list-style-type: none"> <li>• Northeast Multispecies (Groundfish)</li> <li>• Atlantic Sea Scallops</li> <li>• Atlantic Herring</li> <li>• Skates</li> <li>• Small-Mesh Multispecies (Whiting)</li> <li>• Atlantic Deep-Sea Red Crab</li> <li>• Monkfish – managed jointly with Mid-Atlantic</li> <li>• Spiny Dogfish – managed jointly with Mid-Atlantic</li> </ul>	<ul style="list-style-type: none"> <li>• Summer Flounder, Scup, and Black Sea Bass</li> <li>• Atlantic Mackerel, Squid, and Butterfish</li> <li>• Bluefish</li> <li>• Surfclams and Ocean Quahogs</li> <li>• Tilefish</li> <li>• Spiny Dogfish – managed jointly with New England</li> <li>• Monkfish – managed jointly with New England</li> </ul>

adequate preparation and training for software developers, managers, and affected users. The Mid-Atlantic Council is arranging for in-person training sessions and workshops throughout the Greater Atlantic Region and will be hosting online webinars. Any video-based training materials provided by software distributors will be posted on the [eVTR webpage](#) along with available presentations and other helpful outreach tools.

Vessel operators will be able to choose which NMFS-approved eVTR application they prefer to use, and operators will be able to switch applications at any time.

The table below lists free applications that currently are NMFS-approved. Additional systems may be developed and will be added to the list if approved.

The table on the next page lists two applications that come with fees, generally for installation and/or monthly or annual usage. These two fee-based applications are pending recertification to meet GARFO's technical requirements.

**NOTE:** The Mid-Atlantic Council already has an eVTR requirement in place for the [charter and party fleet](#) for species managed by the MAFMC. The New England Council will develop a **separate action** to address eVTRs for recreational for-hire vessels later this year.

The Mid-Atlantic Council has posted a recorded demonstration of the free ACCSP eTrips Mobile app and GARFO's Fish Online app. Watch the [demo recording](#).

## FREE NMFS-APPROVED eVTR APPLICATIONS

APPLICATION / (PROVIDER)	COMPATIBLE DEVICES
eTrips Mobile 2 (ACCSP)	Android and Apple tablet/smartphone, Windows 10, or web browser
Fish Online (GARFO)	iPhone/iPad or web browser
Elog (Teem Fish)	Android and Apple tablet/smartphone, Windows 10, or web browser (used with electronic monitoring)
FLDRS (NEFSC)*	Computer (used for cooperative research)

*The applications above are maintained at no cost to the user. \*FLDRS is designed to collect high resolution fisheries data for research that also satisfies eVTR requirements. FLDRS also is the only current application that complies with reporting guidelines for ocean quahog and surfclams.*



New England  
Fishery Management  
Council



## FEE-BASED eVTR APPLICATIONS

APPLICATION / (PROVIDER)	COMPATIBLE DEVICES
FACTS (Electric Edge)	Windows computer
Olrac DDL (OLSPS)	Web browser, Windows computer, Windows tablet

*(1) Fees are associated with above the applications. (2) The above applications are currently pending recertification to meet GARFO's technical requirements.*

### Why Is This Happening?

The Commercial eVTR Omnibus Framework states that this action is needed to:

- 1) Increase the timeliness and availability of data submitted through VTRs;
- 2) Reduce the reporting burden on data providers (commercial vessel operators) by eliminating the need for paper-based reporting, and
- 3) Increase the accuracy and quality of data by reducing recall bias associated with delayed completion and submission of paper forms.

*NOAA Fisheries said, "Electronic reporting will make the collection of important data on fishing vessel activity more efficient, convenient, and timely" for fishery managers, and other data users.*

Materials used during the New England Council's January 28, 2020 discussion and decision-making are available at [commercial eVTRs](#).

For more information contact either:

➤ **Mid-Atlantic Council** – Karson Coutre at (302) 526-5259, [kcoutre@mafmc.org](mailto:kcoutre@mafmc.org)

➤ **New England Council** – Sam Asci at (978) 465-0492 ext. 116, [sasci@nefmc.org](mailto:sasci@nefmc.org)



MID-ATLANTIC FISHERY MANAGEMENT COUNCIL

### Find Out More! Visit the Commercial eVTR Webpage

The Mid-Atlantic Council established a webpage containing documents and meeting materials related to the joint Commercial eVTR Omnibus Framework Adjustment.

- Take a look at [eVTR info](#).
- Scroll down and sign up to receive eVTR [email updates](#). The sign-up box looks like this:

Sign up to receive email updates:

First Name  Last Name

Email\*

**YOU ARE INVITED  
TO ATTEND THE  
April 17-19, 2020**



## ANNUAL WEEKEND & INDUSTRY TRADE SHOW

**A Full Slate of Activities  
For the Whole Family**

- A super exhibition of the latest goods and services that are important to the lobster/fishing industry as well as Gov. Agencies
- Seminars-Friday and Saturday
- 3 Comedians-Friday evening following dinner
- Craft-Make you own candy bouquet
- Cooking Demonstration-Saturday
- Super MLA Scholarship raffle Fri-Sun
- The Caricature Guy Saturday afternoon
- Banquet Awards Ceremony Saturday evening
- Casino Night Saturday (9-11pm)
- Children's activity room Fri/Sat evening
- There will be many raffles with cash prizes, free drawings and much more!

**Located at the  
Resort and Conference Center at Hyannis**  
35 Scudder Ave, Hyannis, MA 02601  
[www.capecodresortandconferencecenter.com](http://www.capecodresortandconferencecenter.com)

The Massachusetts Lobstermen's Association is working hard to bring to you the 2020 Annual Weekend and Trade Show with many vendors along with several informative seminars Friday and Saturday.

Even if you're not an MLA member *yet!* Come on down, over or up and join us for the event. Remember, this is your industry why not join the MLA for some fun?

**ADMISSION to the  
SHOW is FREE**

For more information on membership, room packages, seminars and vendor information please visit [www.lobstermen.com](http://www.lobstermen.com)  
Or call 781-545-6984 xt.2 & speak with Tracey Abboud.

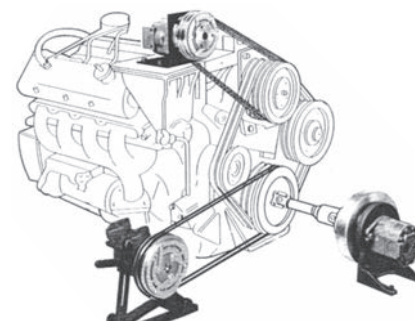

Exhibit Hall Hours: Fri. 9:00am-5:00 pm, Sat. 9:00am-5:00 pm  
Sun. 8:00am-10:00 am

## Ask For



## Electric Clutches



SHAFT OR V-BELT DRIVEN  
MARINE CLUTCHES

**Adaptable, Dependable... Easy to Install & Maintain**

- 75 to 1500 lbs. ft
- 12 or 24 VDC power supply
- Zinc plated – meets ASTM B-117 salt spray test
- SAE pump mount options available

PITTS Authorized Dealer:

**Coastal Hydraulics, Inc.**

603-474-1914 • [sales@coastalhyd.com](mailto:sales@coastalhyd.com)  
[www.coastalhyd.com](http://www.coastalhyd.com)  
28 Route 286, Seabrook, NH

# CBP Alters Jones Act

## Guidance for Offshore Vessels

*A new Jones Act-qualified subsea construction vessel, 2017 (Harvey Gulf)*

The U.S. Customs and Border Protection (CBP) revised key elements of its interpretation of how the Jones Act should be enforced in the U.S. offshore sector. It has rescinded or modified a longstanding set of “letter rulings” on how and when foreign-flag ships may be used in offshore applications, including the use of crane ships. The decision has drawn intense criticism from U.S.-flag offshore vessel operators.

The alterations center on how the agency interprets the term “vessel equipment,” a perennial point of debate for the U.S. offshore oil and gas sector. In a decades-long series of letter rulings, CBP has created a complex framework for determining which objects loaded aboard an offshore construction vessel are cargo - which must be transported by a Jones Act vessel if the voyage is between a U.S. port and a U.S. offshore installation - or “vessel equipment,” which can be carried by any ship.

Relying upon a previous U.S. Treasury ruling, CBP now intends to interpret “vessel equipment” more broadly, to include “all articles or physical resources serving to equip the vessel, including the implements used in the vessel’s operation or activity.” This includes any article that “aids” the full range of

installation and maintenance work on wells, subsea infrastructure, flow lines and surface facilities. An article that leaves the work site with the ship when the job is done is more likely to be “vessel equipment” in CBP’s view, but even objects that are left behind could potentially meet the definition. No examples of specific articles were provided, and CBP says that it expects to receive requests for clarification on a case-by-case basis.

The decision also includes more permissive guidelines for the operation of foreign-flag crane ships. Under previous guidance, CBP ruled that a foreign-flag crane ship could pick up a cargo item that had been carried from a U.S. port by a U.S.-flag ship, then rotate on its own central axis, then install the item at a U.S. offshore site - but not move horizontally with the load suspended. Under the new guidance, horizontal movement is allowed, and a foreign-flag crane ship may set the load down upon its own deck if needed in order to complete the lifting evolution safely.

These changes come despite written opposition from dozens of congressional representatives

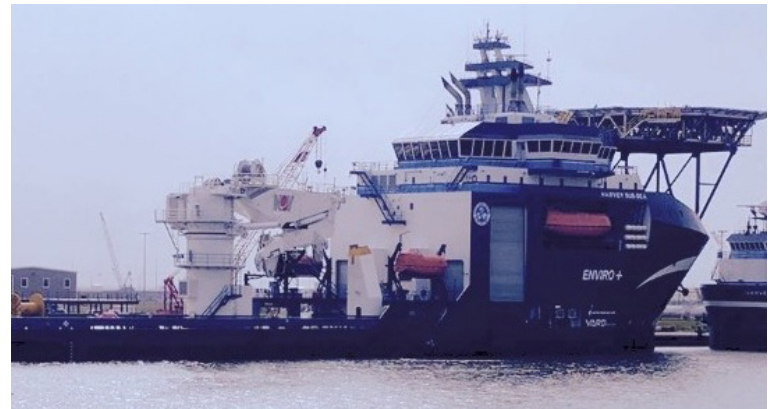

from both parties. The Offshore Marine Services Association (OMSA), which represents America’s offshore services operators, described the decision as a step backwards.

“We are disappointed that [CBP] has decided to put America second by creating potential loopholes for foreign vessels and crews to unlawfully operate in American waters and take the jobs of American vessels and workers,” said OMSA president and CEO Aaron Smith in a statement Thursday. “We support the more than 50 bipartisan members of Congress who correctly asserted that only the U.S. Congress can amend the Jones Act. We will be closely scrutinizing CBP’s implementation of these legally dubious loopholes to ensure that CBP follows the law and requires all foreign-flagged vessels to request and receive letter rulings.” <https://development.maritime-executive.com/article/cbp-alters-jones-act-guidance-for-offshore-vessels>

## FOOD FOR THOUGHT

If you are a fisherman using the “Go-Deep” buoys and have them properly configured GREAT! If you are a fisherman that is using the “Go-Deep” buoys and do not have them properly configured per the 322 CMF 4.13 - Buoy Marking regulations, please be advised that Law Enforcement is out on the water and have sighted several of these noncompliant “Go-Deep” buoys. The “Go-deep” buoys sighted do not have an inserted stick to display a flag and as a consequence the gear marking schemes are out of compliance with the regulation.

Lobster trawl buoy line configurations are regulated under 322 CMF 4.13. One or more sticks at least 3’ long are used on each end and configured to delineate east vs. west end: the east end is configured with a double (2) buoy – with no flag. The west end is configured with a single buoy and a flag on the stick. This gear marking scheme was conceived with the assistance of MLA and dates back to the 1980’s and has been unchanged.

**322 CMF 4.13 - Buoy Marking:** All traps, buoys and lobster cars must bear fisherman’s license number not less than ½” in height nor less than 1/8” in thickness or width of line (for purposes of complying with this requirement, wire traps tagged with trap tags in accordance with CMR 6.31 will be considered sufficient) [Ch. 130 sec.38 and CMR 3.07]. Fisherman’s buoy colors must be displayed on vessel [Ch.130 sec.38A]. Traps require a single 7”x 7” or 5” x 11” buoy; stick is optional [CMR 4.13]. Trawls: East end (South) - double buoy and one or more 3’ sticks. West end (North) - single buoy with 3’ stick and flag. Note Boston Harbor exemption. [CMR 4.13].

**To “Go-Deep” or not; that is the question?**





# New England Marine Engineering & Supply, Inc.

Marine • Industrial • Commercial • Refrigeration

10 TON ELECTRIC TITANIUM RSW  
INTEGRATED MARINE SYSTEMS

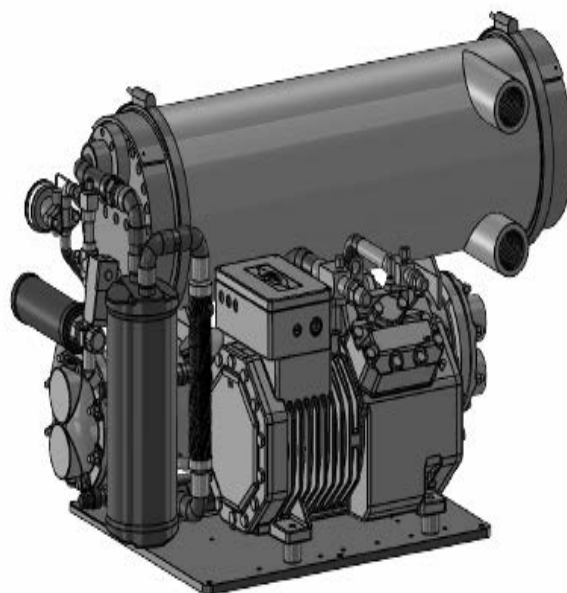

"New England Marine Engineering & Supply, Inc & Integrated Marine Systems, Inc is proud to announce & debut the new IMS 10 Ton Titanium Electric RSW at the 2018 Seafood Processing North America Show on March 11-13 Booth 1875. Come see us and be the first to view the latest IMS system to be introduced to the industry for the fishing vessels ranging from 40' - 80'.

It's going to be the talk of the show."

133 North Front Street, New Bedford, MA. 02740

[www.nemesinc.com](http://www.nemesinc.com) 1.800.540.8893



# ANNUAL WEEKEND & INDUSTRY TRADE SHOW APRIL 16-19, 2020

Dear MLA Member and Annual Weekend Attendee,

In an effort to reduce our carbon footprint we are now going paperless and all the information and registration forms will be sent out in our weekly emails and are available on the MLAs website Annual weekend page [www.lobstermen.com](http://www.lobstermen.com). If you would like the registration forms mailed to you directly please call the MLA office and speak with Tracey at 781-545-6984 xt.2.

The 2020 MLA Annual Weekend and Trade Show is scheduled for April 16-19, 2020 at the Resort and Conference Center at Hyannis, 35 Scudder Ave, Hyannis, MA 02601.

<http://www.capecodresortandconferencecenter.com>

If you have not attended the Annual Weekend and Trade show in many years, well then this is the year you won't want to miss out on all the fun and camaraderie. There will be lots of giveaways, raffles, Casino night, great entertainment and laughs with friends you may not have seen in years!

All rooms and booths are on a first come first serve basis. If you would like a specific room or booth location **DO NOT** delay in getting you reservations in early.

Last years show was a great success thanks to the many MLA members, vendors and show attendees who are dedicated to the fishing industry. The Annual Weekend Committee continues to work hard to bring you new vendors to keep you up to date with all the newest gadgets and equipment in the industry.

If you are interested in helping at the show please call the office and we will be more than happy to have your help. Let's make this 2020 Annual Weekend one to remember!

See you in April, *Annual Weekend Committee*



# ANNUAL WEEKEND & INDUSTRY TRADE SHOW APRIL 16-19, 2020

The Massachusetts Lobstermen's Association will be holding it's Annual Weekend and Trade Show 2020 at the **Resort and Conference Center at Hyannis, Hyannis, MA** on April 16th (set up day) April 19th, 2020. The show hours are Friday and Saturday 9:00 AM-5:00 PM and Sunday 8:00 AM -10:00 AM. The aim of this event is to provide an opportunity for lobster fishermen, dealers and equipment suppliers to get together for communication, education *and to have some fun too*. The Association provides educational grants to college bound children of our members.

The Annual Weekend Committee is asking if you would help us by being a sponsor for one of our show activities or raffles. These are some of the sponsorship opportunities; the Scholarship Fund Raffle, The Hospitality Suite, the Craft, the Entertainment, and the printing of the program.

All contributors will be recognized in the show program. Please note that the show program will go to press on April 5th so we need to have everything in by then.

The MLA currently has over 1,800 members which include lobster fishermen, lobster and seafood dealers and equipment suppliers and works all year for the collective good of the resource and the lobster industry.

## Admission to the Trade Show Exhibit Halls and Seminars is FREE

We sincerely hope that you will consider helping us out and we thank you in advance for any support you can give. *Annual Weekend Committee*

---

Please return letter with your donation.

Name: \_\_\_\_\_ Amount: \$ \_\_\_\_\_

What would you like to sponsor?

- |  |   |
|--|---|
| <input type="checkbox"/> Scholarship Fund Raffle | <input type="checkbox"/> Craft                |
| <input type="checkbox"/> Hospitality Suite       | <input type="checkbox"/> Entertainment        |
| <input type="checkbox"/> Printing of Program     | <input type="checkbox"/> Let Committee decide |

**Thank you for your continued support of the MLAs Annual Weekend and Trade Show**



**Resort And  
Conference  
Center  
At Hyannis**

**Massachusetts Lobstermen's Association  
Annual Weekend and Trade Show 2020**

**HOTEL RESERVATION FORM**

**Thursday, April 16, 2020- Sunday, April 19, 2020**

NAME(S) \_\_\_\_\_

ARRIVAL DATE: \_\_\_\_\_ DEPARTURE DATE: \_\_\_\_\_

ADDRESS: \_\_\_\_\_

CITY: \_\_\_\_\_ STATE: \_\_\_\_\_ ZIP CODE: \_\_\_\_\_

DAY TELEPHONE: \_\_\_\_\_ FAX: \_\_\_\_\_

**E-MAIL ADDRESS (REQUIRED):** \_\_\_\_\_

CREDIT CARD TYPE: \_\_\_\_\_ CREDIT CARD NUMBER: \_\_\_\_\_

EXPIRATION DATE: \_\_\_\_\_ SIGNATURE: \_\_\_\_\_

<b>Hotel &amp; Meal Package Options</b>						
Check Choice	Package Type	Nights	Cost Per Package	Friday Evening Buffet	Saturday Evening Banquet Select One per Adult	
					Prime Rib	Local Cod
	1 Night Package, 1 Adult	Friday Only	\$153.00	Included	Not Included	Not Included
	1 Night Package, 2 Adults	Friday Only	\$189.00	Included	Not Included	Not Included
	1 Night Package, 3 Adults	Friday Only	\$236.00	Included	Not Included	Not Included
	1 Night Package, 1 Adult	Saturday Only	\$189.00	Not Included		
	1 Night Package, 2 Adults	Saturday Only	\$260.00	Not Included		
	1 Night Package, 3 Adults	Saturday Only	\$343.00	Not Included		
	2 Night Package, 1 Adult	Fri & Sat	\$341.00	Included		
	2 Night Package, 2 Adults	Fri & Sat	\$448.00	Included		
	2 Night Package, 3 Adults	Fri & Sat	\$579.00	Included		
	3 Night Package, 1 Adult	Thurs, Fri & Sat	\$457.00	Included		
	3 Night Package, 2 Adults	Thurs, Fri & Sat	\$565.00	Included		
	3 Night Package, 3 Adults	Thurs, Fri & Sat	\$706.00	Included		

**Package prices are inclusive of all taxes, gratuities and service fees.**

<b>Additional Hotel Options</b>			
Check One	Additional Nights	Indicate Dates/Number of Adults	Cost
	I want the package as noted above plus additional hotel nights pre or post package nights. Rate is per night and is inclusive of tax.		\$113.31 Per Night
	Hotel Only. No meals included. Rate is per night for 1 or 2 adults. Rate is inclusive of tax.		\$130.47 Per Night



**RESERVATION POLICIES**

**Cutoff Date:** All reservations for guestrooms must be made by April 3, 2020. After this date, we cannot guarantee the availability of guestrooms or the group rate.

**Meal Tickets and Choices:** All meal choices for the Saturday night banquet must be made prior to April 3, 2020. If meal selection is not made by this date, we cannot guarantee your preferred meal choice. *Meal selections and number of guests in the package may not be adjusted within 10 days of arrival.*

**Deposit:** We require a deposit of \$100.00 at the time the reservation is made. If the deposit is by credit card, we will charge the deposit in advance when the Reservation Form is received.

**Cancellation Policy:** If an individual reservation is cancelled (14) fourteen days or more prior to arrival the deposit is refunded less a \$15.00 service charge. If an individual reservation is cancelled (13) thirteen days or less or the guest does not arrive on the specified dates, the reservation is cancelled for all nights and the deposit will be forfeited. The remaining nights on the reservation will also be cancelled and are not automatically reinstated.

**Confirmation:** A confirmation email will be sent to you directly from the Resort and Conference Center at Hyannis.

**CHECK-IN TIME AFTER 3:00 PM - CHECK-OUT TIME BY 11:00 AM**

Please Fax, Email or Mail completed form to our Reservations Department (1 form per room)

Fax: 508-778-6039

Email: [stay@capecodresortandconference.com](mailto:stay@capecodresortandconference.com)

Mail: Resort & Conference Center at Hyannis, 35 Scudder Avenue, Hyannis, MA 02601.

Please make checks payable to the Resort and Conference Center at Hyannis.

This form must be received prior to April 3, 2020. Phone or online reservations will not be accepted.

Any changes to your reservation must be made by submitting a revised form.  
Please note change and mark form as "REVISED" to avoid duplicate reservations.

**Bait Claw**

The original Bait Claw is a bait loading tool that gives you an extra hand filling bait bags. It saves time, saves money and makes loading bait bags a breeze.

Load Bait Bags **easier** and **faster** with the **Bait Claw**.

Durable & Strong      Saves Time Saves Money      Gives you an extra hand

Available now at [www.thebaitclaw.com](http://www.thebaitclaw.com)

FEBRUARY 2020

**MLA Annual Weekend & Lobster Trade Show 2020**  
**RESORT AND CONFERENCE CENTER AT HYANNIS, MA**  
**Order Form for Extra Meal Tickets**

Day/Time	Description	Price Per Person	Number Requested	Total Price
4/17/20 Friday Evening 6:30 pm – 7:45 pm  Comedy Show 7:45pm to 9:00pm	<u>Buffet Dinner</u>  * Soup- Roasted Tomato Soup * Mixed Garden Greens, Vegetables * Chicken Marsala with mushrooms and Marsala Wine * Braised Beef Short Ribs * White Chocolate Bread Pudding * Coffee, Decaf-Coffee & Tea	\$50		
4/18/20 Saturday Evening 6:30 pm Dinner  Award Ceremony 8:00pm  Casino Night 9:00pm – 11:00pm  Please choose Entrée	<u>Banquet Dinner</u> Local Cod or Prime Rib of Beef with Warm Rolls, New England Clam Chowder, Caesar Salad, Chef's choice of Starch, Vegetable, Dessert, Coffee, and Tea  (Please Choose Entrée)  Local Cod-  Prime Rib of Beef-	\$65		
Total Amount Enclosed: \$				

Name: \_\_\_\_\_ Tel : \_\_\_\_\_

Address: \_\_\_\_\_

<input type="checkbox"/> Visa <input type="checkbox"/> Master Card <input type="checkbox"/> Check payable to <u>MLA</u>
Name on Card _____ Card Number: _____ Exp Date: _____ Last 3 numbers on back of card: You may call this number in: _____ Signature: _____ Today's Date: _____

**Return this form to:**  
 Massachusetts Lobstermen's Association  
 8 Otis Place, Scituate, MA 02066  
 O. 781-545-6984 xt 2  
 Email: [tracey.abboud@lobstermen.com](mailto:tracey.abboud@lobstermen.com)

Rope

Totes

KETCHAM

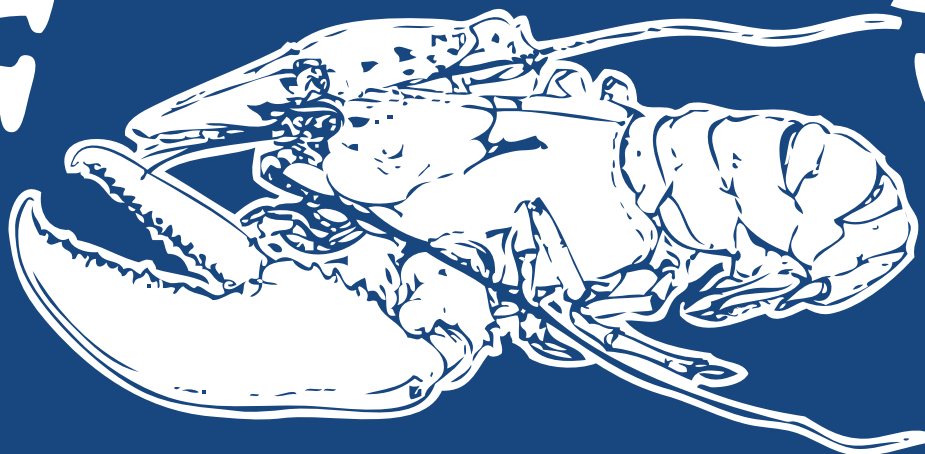

Clips

Buoys

TRAPS

Tools

Traps

111 Myrtle Street  
New Bedford, MA 02740

 @ketchamsupply

[www.ketchamsupply.com](http://www.ketchamsupply.com)  
[info@ketchamsupply.com](mailto:info@ketchamsupply.com)

508.997.4787



# ANNUAL WEEKEND & INDUSTRY TRADE SHOW April 16 - 19, 2020

Dear Exhibitor;

We are excited to offer you the opportunity to celebrate with us and to present and/or sell your products and services to a group of more than 1,800 commercial fishermen during our Annual Weekend & Trade Show starting on Friday, April 17<sup>th</sup>-19<sup>th</sup>, 2020. (*The 16<sup>th</sup> is vendor set up day*) The event will be held at the Resort and Conference Center at Hyannis, MA. <http://www.capecodresortandconferencecenter.com>

In an effort to reduce our carbon footprint, all the show information and registration forms will be sent out in our weekly emails and available on the MLA website; Annual Weekend page [www.lobstermen.com](http://www.lobstermen.com). If you need the registration forms mailed to you directly, please call the MLA office and speak with Tracey at 781-545-6984 xt.2.

- The MLA recognizes that you may not have time to eat lunch on set up day; we will provide a boxed lunch in the exhibit hall on Thursday, April 16<sup>th</sup>, 12:00 PM -1:00 PM. (*While supplies last*)
- In addition to the (9-5) Friday and Saturday hours, the exhibit hall will be open on Sunday morning an hour earlier at 8:00 AM and remain open until 10:00 AM so that you will have two hours of uninterrupted time.
- The MLA gives cash prizes to those exhibitors who remain set up until 10:00 AM on Sunday. (YOU MUST BE AT YOUR BOOTH BY 8:00 AM TO GET YOUR TICKET)
- A single Booth space includes one 6' table with a tablecloth and 2 chairs. We will work with you if you need a little more room.

Once we receive your payment, we will mail you a confirmation letter for your booth and have it waiting for you beginning at 10:00 AM on Thursday, April 16<sup>th</sup> for set-up. If the Thursday set-up day is a difficulty for you, we can make special arrangements to admit you early on Friday morning April 17<sup>th</sup>. However, please be advised that the Exhibit Hall opens at 9:00 AM and all exhibits must be fully set up by then. (Show hours are Friday & Saturday 9:00 AM – 5:00 PM and Sunday 8:00 AM -10:00 PM)

All goods must be removed by 1:00 PM on Sunday afternoon, April 19<sup>th</sup>. If you are unable to remove your entire exhibit by this time, you may make special arrangements for Monday morning as long as arrangements are made in advance.

If you have any questions or need further information, please contact the MLA office and speak with Tracey 781-545-6984 ext 2.

We look forward to seeing you in April. Thank you, *MLA Annual Weekend Committee*

**Massachusetts Lobstermen's Association**  
 8 Otis Place, Scituate, MA 02066-1323  
 Tel (781) 545-6984  
 Tracey.Abboud@lobstermen.com

**Annual Weekend & Trade Show 2020**  
 April 16th - April 19th 2020 (set up on April 16th)  
 Resort and Conference Center of Hyannis  
 35 Schudder Ave, Hyannis, MA 02601

**Exhibitor Booth Reservation—2020**

**Booth's include a 6' covered table & 2 chairs**

- ( ) 1 Booth \$650 \_\_\_\_\_
- ( ) 2 Booths \$950 \_\_\_\_\_
- ( ) 3 Booths \$1250 \_\_\_\_\_
- ( ) Electricity \$75 \_\_\_\_\_
- ( ) Lift for Engine \$150 \_\_\_\_\_

**Total Enclosed \$** \_\_\_\_\_

Set-up begins at 9:00 AM on Thursday (April 16th) and must be completely removed by 1:00 PM on Sunday unless other arrangements have been made in advance.

**ALL BOOTHS MUST REMAIN INTACT AND YOU MUST BE AT YOUR BOOTH BY 8:00 AM Sunday to qualify for the vendor raffle. 4 CASH PRIZES THE BOOTH MAY NOT BE DISMANTLED UNTIL 10:00 AM ON SUN. (April 19th)**

Company Name: \_\_\_\_\_

Address: \_\_\_\_\_

City, State, Zip Code: \_\_\_\_\_

Daytime Tel: \_\_\_\_\_ Fax : \_\_\_\_\_

Person in Charge of Booth: \_\_\_\_\_ E-mail: \_\_\_\_\_

Primary Product or Service: \_\_\_\_\_

(If you are having an engine delivered PLEASE call and schedule a delivery time with Tracey Abboud 781-545-6984 xt. 2 —Thank you)

Special Requests or Needs: \_\_\_\_\_

Payment Info: ( ) MasterCard ( ) Visa ( ) Check (Payable to MLA )

Name on card: \_\_\_\_\_

Card # \_\_\_\_\_

3 numbers on back of card: \_\_\_\_\_ Card Exp Date \_\_\_\_\_

(You may call this number in)

Signature: \_\_\_\_\_



# ANNUAL WEEKEND & INDUSTRY TRADE SHOW APRIL 16-19, 2020

Dear Annual Weekend & Industry Trade Show Sponsor,

The Massachusetts Lobstermen's Associations' 2020 Annual Weekend and Trade Show is scheduled for April 16-19, 2020 at the Resort and Conference Center at Hyannis, Hyannis, MA. We wanted to give you enough time to plan accordingly for this year's event.

The MLA is offering activities sponsorship opportunities for vendors who will be able to display a banner, provided by you, at the activity along with preferential ad placement in the show program. All ads and banners are provided by sponsor and will be returned after show.

A **Platinum** sponsorship will provide you with 2 full page color ads in the show program along with displaying your company's banner in the location of your choice. A **Gold** sponsorship will provide you with a full page ad in the show program along with displaying your company's banner in the location of your choice.

A **Silver** sponsorship will provide you with a ½ page ad in the show program along with displaying your company's banner in the location of your choice. The **Bronze** sponsorship will list the companies name in the program along with displaying your company's banner in the location of your choice.

Activities to be sponsored are the hospitality suite, the craft, seminars, casino night and the entertainment all of which are well attended and well received by MLA members and Show attendees.

Sponsorship levels;

- Platinum sponsorship \$2500.00 banner size 4' x 8' – 2 full page color ad in show program
- Gold sponsorship \$1000.00 banner size 3' x 6' – 1 full page ad in show program
- Silver sponsorship \$500.00 banner size 2' x 5' - ½ page ad in show program
- Bronze sponsorship \$250.00 banner size 2' x 5' – company will be listed in the show program

Name: \_\_\_\_\_ Amount: \$ \_\_\_\_\_

What would you like to sponsor?

- Entertainment
- Hospitality Suite
- Seminars
- Casino night
- Craft
- Let Committee Decide

Let's make the 2020 Annual Weekend & Trade Show one to remember! Please return this letter with your donation. Thank you and we'll see you in April, [Annual Weekend Committee](#)

# WE DELIVER FRESH LOBSTER BAIT

**INCLUDING:**

**HERRING**

**POGIES**

**MACKEREL**

**RED FISH**

**SKINS**

**BLUEFISH**

**CHUM**

**SALMON  
HEADS**



***FRESH, SALTED, AND QUICK FROZEN BAIT***

## **Barrel Head Bait**

***WE SELL SALT!***

**For More Information:**

**To Place An Order:**

**Mark Flight**

**mark@barrelheadbait.com**

**The Bait Line:**

**857-200-2129**

**Or Fax:**

**617-561-8471**



New England Marine & Industrial  
www.newenglandmarine.com

## Lobster Bands

We carry:  
Printed and Non Printed  
Sheddar  
Standard  
Cold Water Sheddar  
Jumbo

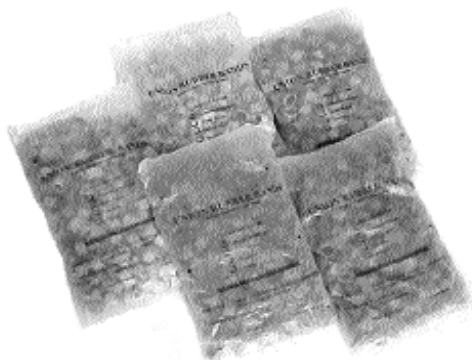

Buy them by the 1 pound bag, by the case or by the pallet. We also offer wholesale and volume discounts. Call and ask to speak to a salesman.



**Dayglo &  
Flexabar  
Buoy Paint**



**Spongex Buoys**  
Full selection of sizes  
in Stock

Worcester Cow Hide Bait  
We carry Regular and Hairless Bait  
Call for Special Pricing on both 5 pail  
purchases and pallet (20 pails) purchases  
“One week notice needed on pallet purchases”

200 Spaulding Tpke  
Portsmouth, NH  
603-436-2836

294 Ocean St  
Brant Rock, MA  
781-834-9301

86 Cemetary Rd  
Stonington, ME  
207-367-2692





# Atlantic States Marine Fisheries Commission NEWS RELEASE

*Sustainable and Cooperative Management of Atlantic Coastal Fisheries*

FOR IMMEDIATE RELEASE  
January 21, 2020

PRESS CONTACT: Tina Berger  
703.842.0740

## American Lobster Benchmark Stock Assessment Workshop Scheduled for February 24-27, in Narragansett, RI

Arlington, VA – The Atlantic States Marine Fisheries Commission will hold a second American Lobster Benchmark Stock Assessment Workshop on February 24 – 27 at the University of Rhode Island Bay Campus, 215 South Ferry Street, Narragansett, Rhode Island. The stock assessment, which is scheduled for completion in the summer of 2020, will evaluate the health of the Gulf of Maine/Georges Bank and Southern New England stocks and inform management of this species. The Commission's stock assessment process and meetings are open to the public, with the exception of discussions of confidential data\*, when the public will be asked to leave the room.



The draft agenda for the workshop is available at [http://www.asmfc.org/files/Meetings/AmericanLobsterAssesmentWorkshopII\\_DraftAgenda\\_Feb2020.pdf](http://www.asmfc.org/files/Meetings/AmericanLobsterAssesmentWorkshopII_DraftAgenda_Feb2020.pdf). For more information about the assessment or attending the upcoming workshop (space will be limited), please contact Caitlin Starks, Fishery Management Plan Coordinator, at [cstarks@asmfc.org](mailto:cstarks@asmfc.org) or 703.842.0740.

\* Each state and federal agency is responsible for maintaining the confidentiality of its data and deciding who has access to its confidential data. In the case of our stock assessments and peer reviews, all analysts and, if necessary, reviewers, have been granted permission by the appropriate agency to use and view confidential data. When the assessment team needs to show and discuss these data, observers to our stock assessment process are asked to leave the room to preserve confidentiality.

###

PR20-02

The Atlantic States Marine Fisheries Commission was formed by the 15 Atlantic coastal states in 1942 for the promotion and protection of coastal fishery resources. The Commission serves as a deliberative body of the Atlantic coastal states, coordinating the conservation and management of nearshore fishery resources, including marine, shell and diadromous species.

1050 N. Highland Street • Suite 200A-N • Arlington, VA 22201  
703.842.0740 (phone) 703.842.0741 (fax) www.asmfc.org

# Funding Opportunity Research Announced

(Deadline March 19)



Photo credits: Rebecca Irelan (Center - NH Sea Grant), Lindsey Williams (Left and Right, MIT Sea Grant)

A new funding opportunity has recently been announced that may be of interest to MLA newsletter readers!

The 2020 Sea Grant American Lobster Research Program is the second round of funding for research projects as part of Sea Grant's American Lobster Initiative. The funding competition is run by NOAA's National Sea Grant Office, not the Regional Lobster Extension Program.

The American Lobster Research Program will support research to address critical gaps in knowledge about how the American lobster and its fishery is being impacted by environmental change. Priority research topics suitable for study under this Notice of Funding Opportunity should have a geographic focus on the Gulf of Maine, Georges Banks, and/or southern New England and address one or more of the following:

- (1) Increased understanding of life history parameters, including but not limited to, growth, maturity, and species interactions;
- (2) Larval ecology and early biology;
- (3) Spatial distribution and migration, including but not limited to, habitat and trophic interactions; and/or
- (4) Socio-ecological investigations to inform future management decisions, including but not limited to, research exploring bait alternatives to herring and their implications for the lobster fishery.

Pending appropriation of funds, Sea Grant anticipates awarding five to ten research projects of up to \$400,000 each, totaling between \$1 million and \$2 million in FY2020. Projects must have a maximum duration of two years and proposals are due on March 19, 2020.

More details can be found at: [seagrant.noaa.gov/Funding](https://seagrant.noaa.gov/Funding)

General questions about the competition should be emailed to [oar.hq.sg.competitions@noaa.gov](mailto:oar.hq.sg.competitions@noaa.gov).

If you have ideas for research, we encourage you to reach out to those you've worked with in the past to develop proposals for this opportunity. If you have an idea and are looking for potential research

partners, please don't hesitate to reach out to regional Sea Grant staff for assistance connecting with researchers in the region. Contact information for Sea Grant Extension staff in each state who are working on the American Lobster Initiative is included below.

### Extension Project Contacts:

Institution/ State	Contacts	Contact Information
Maine Sea Grant (regional coordination role)	Beth Bisson Chris Bartlett	beth.bisson@maine.edu cbartlett@maine.edu
New Hampshire Sea Grant	Gabriela Bradt Alexa Brickett	gabriela.bradt@unh.edu alexa.brickett@unh.edu
MIT Sea Grant (MA)	Carolina Bastidas	bastidas@mit.edu
Woods Hole Sea Grant (MA)	Jennie Rheuban	jrheuban@whoi.edu
Connecticut Sea Grant	Anoushka Concepcion Nancy Balcom	anoushka.concepcion@uconn.edu nancy.balcom@uconn.edu
Rhode Island Sea Grant	Azure Cygler Dawn Kotowicz	acygler@uri.edu dkotowicz@uri.edu
New York Sea Grant	Antoinette Clemetson Kathy Bunting-Howarth	aoc5@cornell.edu keb264@cornell.edu

## NOAA Right Whale Regulations

continued from page 2

“weak contrivances”. The field testing will begin this year so to ensure a functional option will be available for the 2021 fishing season. There is one other acceptable “weak contrivance” option available today, the South Shore Sleeve. This is the Chinese finger sleeve that has been tested and is being used by a few SS lobstermen without incident. The commercial lobster industry needs multiple safe options to achieve the 1700lb “weak contrivance” and not every 40’ as being pushed by the ENGO’s which the DMF has made clear they do not support. Just imagine if you fished in 400’ of water, you would have to incorporate 10 sections of this “weak contrivance” and hope that you could safely retrieve your gear?!

Now, that you have digested all of this you may be asking yourself, “When will all of this go into place?” Well, the proposed rules are not expected to be released until mid-March or so and once they are released GARFO/NMFS will hold public hearings up and down the coast to gather input and recommendations from the commercial lobster industry, environmentalists, state agencies and concerned citizens. If you have never attended a public hearing now is the time to not miss these ones. Your comments and recommendations matter. The commercial lobster industry needs everyone to show up and comment even if it is to say “I support the MLAs position” or “I support the previous fisherman.” The MLA will continue to keep you updated on all things whale related. If you would like to be added to our email list please email [beth.casoni@lobstermen.com](mailto:beth.casoni@lobstermen.com) and in the subject line put “Please add me to you email list”. Stay tuned!!



**MARINE • FISHING GEAR • SAFETY**  
44 South Street, New Bedford, MA 02740

**DSPA 5 M**

OUR NEWEST FIRE PROTECTION

[www.Hercules-SLR-US.com](http://www.Hercules-SLR-US.com)

[JohnReardon@Hercules-SLR-US.com](mailto:JohnReardon@Hercules-SLR-US.com)

**USCG Safety Inspection Station #327**

## Commercial Fishing-Marine Safety-Rigging

- ❖ Marine Hardware
- ❖ Cotesi - Netting, Leaded/Sink Rope
- ❖ Stormline & Climate Technical-Foul Weather Gear
- ❖ Buoys & Floats
- ❖ Lobster Bands
- ❖ PFD's, Vests, Float Coats
- ❖ Fish Totes
- ❖ Insulated Tubs
- ❖ Cordage & Twine
- ❖ Mooring Equipment
- ❖ Boarding Ladders
- ❖ Leadline
- ❖ Wire Rope - FC Galv, IWRC, Dyform
- ❖ HiFlyers 12', 14' & 15' XHD
- ❖ Golf & Batting Cage Netting



Inflatable PFD's



### Life Raft Sales

- ❖ Revere
- ❖ Elliot
- ❖ Survitec
- ❖ Switlik

All brands accepted for service



**DEXTER**  
RUSSELL CUTLERY  
A Dexter Russell Distributor



Fenders & Buoys-All Colors



Boots from  
Honeywell Safety



**XTRATUF**



**SERV**  
by Honey



**ACR Electronics**  
Sales & Service  
for your E.P.I.R.B.



**Imperial Survival Suits**  
**Inspections & Safety Drills**

**Polysteel Rope- Esterpro**  
**Sinking, Hydropro**

Call our USCG Certified Drill Conductor  
Ted Williams 508-264-5779



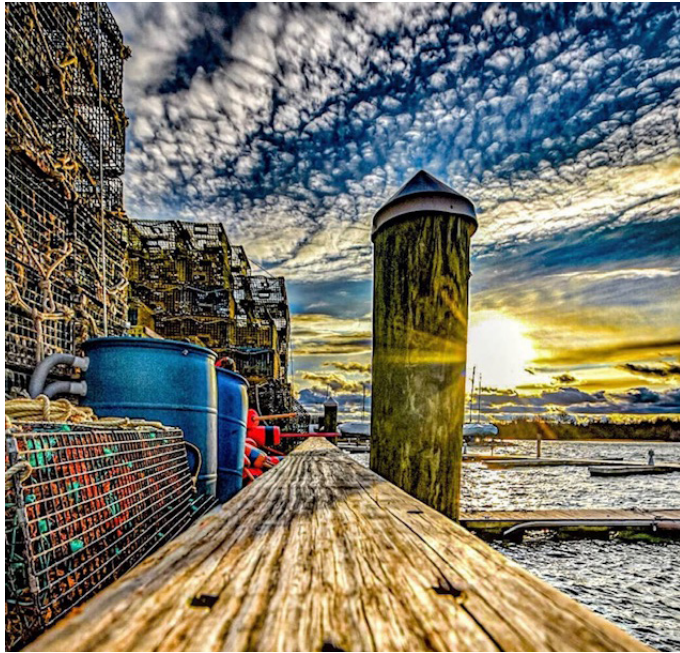

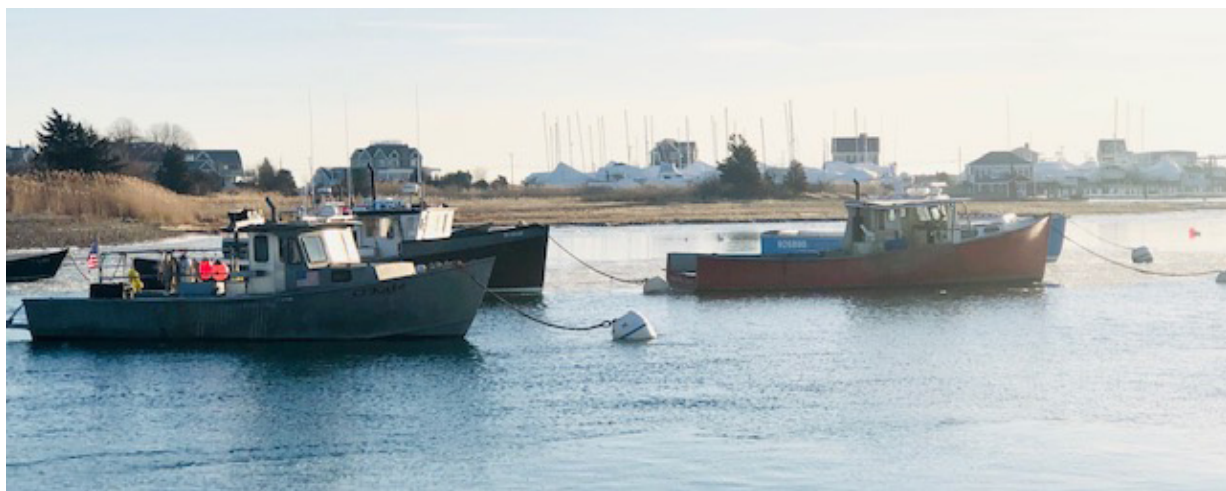

# ANNOUNCING MONTHLY PORT HOURS

with Fisheries Liaisons from the RI/MA Wind Energy Areas

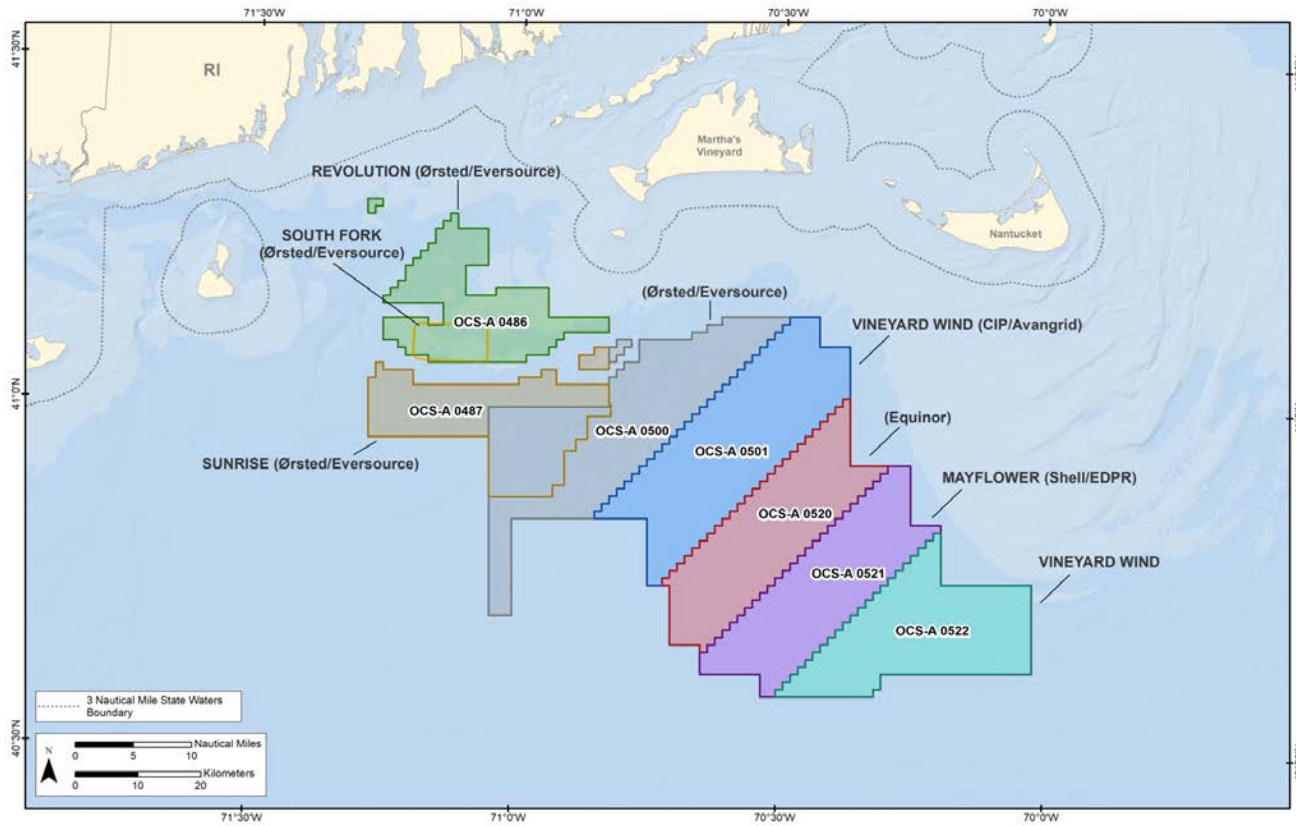

Beginning January 2020, Equinor, MayFlower, Ørsted and Vineyard Wind fisheries liaisons will be available during port hours for commercial and recreational fishing inquiries, comments and feedback for the RI/MA Wind Energy Areas.

Please stop by for informal conversation at the following scheduled times and locations:

**Point Judith conference room above Superior Trawl**

**55 State Street Narragansett, RI 02882**

**First Thursday of every month**

**8am - 12 pm**

**Jan. 2, Feb. 6, Mar. 5, Apr. 2, May 7, Jun. 4**

**New Bedford Port Authority**

**52 Fishermen's Wharf New Bedford, MA 02740**

**First Friday of every month**

**8am - 12 pm**

**Jan. 3, Feb. 7, Mar. 6, Apr. 3, May 8, Jun.5**

Questions regarding the monthly port hours please contact fisheries liaisons at:

Elizabeth Marchetti	Ruth Perry	Rodney Avila	Chris Sarro	Crista Banks	Caela Howard
Equinor	MayFlower	Ørsted	Ørsted	Vineyard Wind	Vineyard Wind
401.954.2902	346.410.9355	508.889.0402	508.245.7924	508.525.0421	860.575.3501



## PACIFIC LEGAL FOUNDATION

For the last three years, the Massachusetts Lobstermen's Association and other commercial fishing organizations have been challenging the Northeast Canyons and Seamounts Marine National Monument as an abuse of the President's Antiquities Act powers. Contrary to the monument, the Antiquities Act only applies to "land owned or controlled by the Federal Government" and requires monument boundaries to be drawn as small as practicable.

Unfortunately, a three-judge panel from a federal appeals court ruled against this challenge in late December and endorsed an extremely broad understanding of the President's power. Although a disappointment, this is not the end of the matter. Soon, we will ask the entire court to consider the case and to overrule the three-judge panel.

The outcome of this case will ultimately be determined by the Supreme Court, which will not be bound by the lower court's decision. Because of the economic and social importance of the monument, as well as its impact on the separation of powers between Congress and the President, it deserves the Supreme Court's close scrutiny.

Jonathan Wood | Senior Attorney

Pacific Legal Foundation

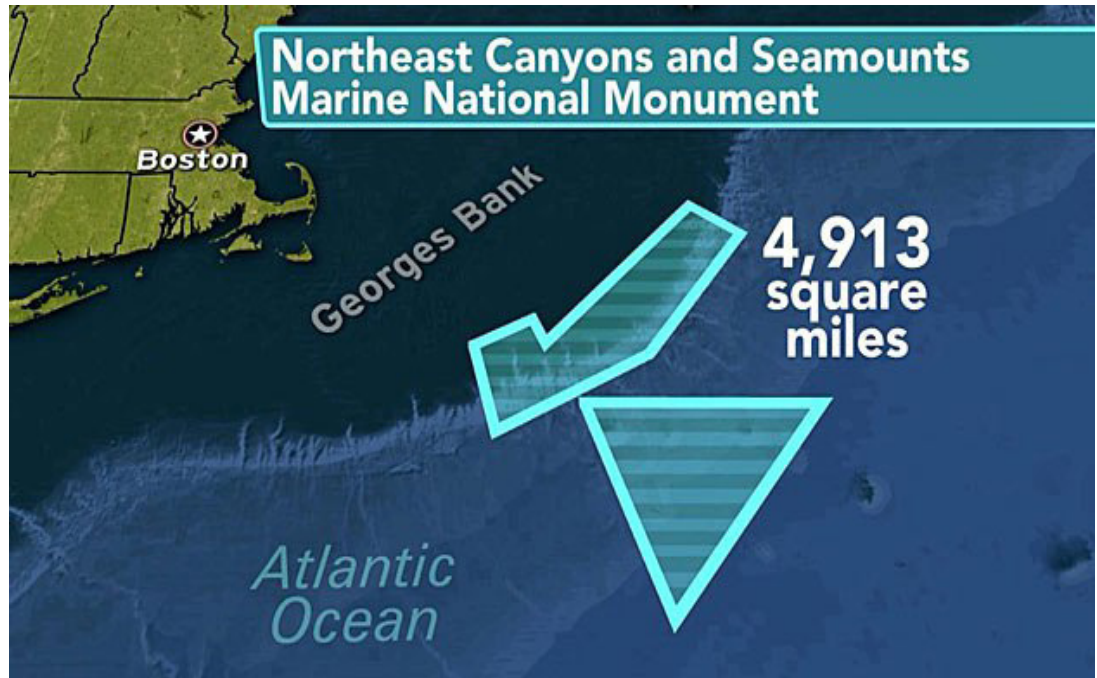

Encore Hartco Tools & Clips  
 Stanley Spenax Tools & C-Rings  
 Wematic Tools & D-Rings  
 Simonds Pneumatic Wire Cutters  
 Spotnail Staplers & Staples



Complete Parts Inventory  
 Tool Repair Service

(781) 826-2522  
 Fax (781) 826 5252  
[www.fisherairfasteners.com](http://www.fisherairfasteners.com)  
[chris@fisherairfasteners.com](mailto:chris@fisherairfasteners.com)

# HAMILTON MARINE

**ICOM MR1010RII Radar**  
 10.4" color TFT LCD display. 36NM range with 4kW output. Includes 2' radome scanner. DSC capable when connected to a DSC radio. Also connects to AIS.

**\$1999<sup>99</sup> ea**



ICM-MR1010R2  
 Order# 773501

**RIGID High Performance LED Lights**

High purity aluminum housing. Provides superior light with low power consumption.  
 Search# RIL-

Starting At **\$125<sup>99</sup> ea**



**KENT Type I Offshore Commercial Life Vest**

**USCG APPROVED**

Adult universal. 22 lbs buoyancy. SOLAS grade reflective tape. Light loop and whistle attachment.

**\$37<sup>60</sup> ea**

PFD-1A  
 Order# 748930



**IMPERIAL Adult Universal Cold Water Immersion Suit**

**USCG APPROVED**

Three fingered mitt. Wide legs for easy donning. Snug fitting face seal. Retro-reflective tape. Includes whistle and storage bag.

**\$269<sup>99</sup> ea**

RVS-1409A  
 Order# 743829



**BEACON 35 Automatic/Manual Inflatable PFD**

**USCG Approved Type V with Type II Performance Full 35 lbs buoyancy for offshore use!**

Universal sizing, fits 30"-65" chest. Comfortable low profile fit, neoprene neckline. Super bright retro-reflective areas on front, a high-visibility BEACON logo on the back.

Reg 179.99

**\$149<sup>99</sup> ea**

Color Order#  
 Orange/Gray 773536  
 Blue/Light Gray 773535



**SAVE \$30**

**JIM-BUOY® 24" Orange Life Ring**

**USCG Approved with Reflective Tape**

**\$74<sup>69</sup> ea**

CAL-G24-OT  
 Order# 105283



**Scalloper Apron**

Tough apron with exceptional comfort! Front is orange Cap-Coz PVC fabric. Shoulders are mesh Power Dry™ Polartec™ fleece. Back closure by side release buckle. Features detachable reinforcement cut guard with snaps on front.

**\$67<sup>88</sup> ea**

Size Order#  
 L 773788  
 XL 773789



**GRUNDÉNS Foul Weather Gear**

Jackets, bib pants, aprons, barvels, sweatshirts, boots and more!

Search# GRD-

**FULL LINE IN STOCK!**



**Double Coated Insulated Latex Gloves**

Textured palm for excellent grip. Comfortable knit cuff. Sold by the pair. Sizes S-2XL.

**\$9<sup>35</sup> pr**

Search#  
 HMG-WG338

**WAYNE HAMILTON'S CHOICE!**



**Big Bobby Wide Calf Boots**

Rugged solid rubber sole, oil resistant. Special broad toe. Reinforced heel. 100% waterproof. 4-way stretchable, breathable Airmesh™ lining. Sizes 10-16.

Mid 13" Boot  
 Search# **\$99<sup>95</sup> pr**  
 CFD-BBBMM

High 16" Boot  
 Search# **\$104<sup>95</sup> pr**  
 CFD-BBBMH

**UP TO SIZE 16!**



**Carhartt Base Layer Tops and Bottoms**

Medium and heavyweight tops and bottoms designed for durability, comfort and warmth.

Starting At **\$29<sup>99</sup> ea**

Search# CRH-MBL

Women's tops available in Deep Wine.





**Electric Rope Cutting Guns**

100 Watts  
**\$32<sup>82</sup>** ea

PUR-15463  
Order# 127675

120 Watts  
**\$37<sup>45</sup>** ea

PUR-15463HD  
Order# 735613



**5/16" Black Shock Cord**

UV resistant, solid black.  
Order# 740364

**43¢** ft **\$103<sup>99</sup>**  
500 Ft Spool

Double UV cover, black w/green tracer.

Order# 740363

**43¢** ft **\$114<sup>58</sup>**  
500 Ft Spool



**Hamilton Marine Lobster Buoy Paint**

Extra tough, long lasting, flexible coating, UV & weather resistant, low odor, fast drying, soap and water cleanup. Available in Red, Orange, Yellow, Green, Blue, Black or White.

Search# HM-LBP

**\$14<sup>99</sup>** qt **\$49<sup>99</sup>** gal



SCAN THIS QR CODE!

See just how tough our buoy paint is!



**1/2" Black Fuzzy Rope**

Sold in 1200 ft coils.  
For use in mussel farming.



AQC-FR50BK  
Order# 763256

**Lantern Nets**

Aquaculture lantern nets, for use in scallop farming.

Description	Order#
4mm 5 Tier	763277
4mm 7 Tier	769870
9mm 5 Tier	763278
9mm 7 Tier	769871



**A4 Inflatable Net Buoys**



21" diameter x 27" long, 68" circumference.  
95 lbs buoyancy.  
POL-A4Y Order# 774850



**LD Hardshell Low Drag Buoys**



6" x 13" or 7.25" x 22".  
Available in Green, Orange, Pink, Red, White or Yellow.  
Search# HML-BUOYL

**Lobster Buoys**

Spongex  
HML-BUOY-

Size	Order#	#/Case
5 x 11	118250	48
6 x 14	118252	25
7 x 7	118258	35
7 x 14	118254	18
7 x 15	118256	20
8 x 18	733096	12
9 x 16	138583	12



**Hairless Salted Pig Hide Lobster Bait**



HML-HIDEBAIT  
Order# 740935

**Fish Baskets**

Round, orange plastic with handles and holes for draining, approx. 1 bushel capacity.

**\$19<sup>99</sup>** ea

Orange  
Order# 118243

Green  
Order# 763280



**Fish Totes**

Plastic. No Holes.

Starting At  
**\$15<sup>56</sup>** ea



Color	Dimensions	Capacity	Order#
Black	28"L x 16"W x 11"D	70 Liters	118291
Gray	28"L x 16"W x 11"D	70 Liters	736466
Blue	28"L x 16"W x 14"D	85 Liters	760085

**COOSA COMPOSITES Composite Panels**

Use in place of plywood!

High density, polyurethane foam, reinforced with layers of fiberglass strands throughout. Lightweight, non-rotting.  
Search# CSA-



**STRONGWELL Extren® Fiberglass Structural Shapes & Plates**

Get the wood out!

Lightweight, and high strength, low maintenance, corrosion and UV resistant. Available in many sizes and shapes.  
Search# SGW-

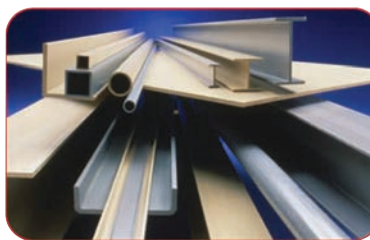

**FREE HEAT from your engine's closed cooling system!**

**MARINE HEAT** Flush mount or ducted models. From 28,000 - 40,000 BTUs

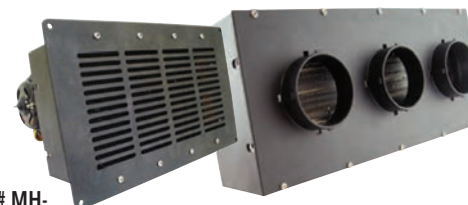

Search# MH-

**FM FREEMAN MARINE EQUIPMENT Cast Aluminum Commercial Hatches**

Flush, watertight, rugged and durable. Fast acting and easy opening.

15" x 24"  
**\$797** ea

Reg 884.99  
FMN-2433-0002  
Order# 754527



24" x 24"  
**\$1497<sup>65</sup>** ea

Reg 1659.99  
FMN-2424-0002  
Order# 754529



**Bridge Plank**

Rubber bridge plank with textured top. 12" x 24" x 1/2" thick.

**\$9<sup>99</sup>** ea

HM-BPLANK50  
Order# 757474

**Bridge Plank Cement**

HM-BPLANK-ADH **\$133<sup>39</sup>** 3.5 gallon



All discounts apply to current store prices. Typographical errors are unintentional and subject to correction.



## New England Fishery Management Council

50 WATER STREET | NEWBURYPORT, MASSACHUSETTS 01950 | PHONE 978 465 0492 | FAX 978 465 3116

John F. Quinn, J.D., Ph.D., *Chairman* | Thomas A. Nies, *Executive Director*

### MEETING SUMMARY

#### Habitat Committee

Four Points by Sheraton, Wakefield MA  
January 22, 2020

The Habitat Committee and Advisory Panel met jointly to discuss Council research priorities, an EFP application for the Great South Channel HMA, offshore renewable energy development, and Council policies on non-fishing impacts to habitat. The group also received an update on the Northeast Regional Habitat Assessment.

**MEETING ATTENDANCE:** Committee: Eric Reid (Chair), Peter Aarrestad, Terry Alexander, Rick Bellavance, Lou Chiarella, Peter deFur, Libby Etrie, Peter Hughes, Scott Olszewski, Melissa Smith; Advisory Panel: Gib Brogan, Beth Casoni, Rip Cunningham, Ben Haskell, Lane Johnston, Jeff Kaelin, Elizabeth Marchetti, Drew Minkiewicz, Ron Smolowitz, Dave Wallace; Michelle Bachman (NEFMC staff, PDT Chair); Mitch McDonald (NOAA General Counsel); Mike Ruccio (GARFO).

Public attendees: Elizabeth Hansel, Allen Rencurrel, Chris Sarro, Scott Lang, Louie Legace, Patrick Paquette, John Williamson, and Kevin Staples.

#### KEY OUTCOMES:

- Related to research priorities, the Committee and Advisory Panel made a series of recommendations (Motions 1-4) to adjust the description and scope of certain priorities.
- Related to the EFP for the Great South Channel HMA, the Committee and Advisory Panel listed a range of ideas and concerns about the proposal which will be brought to the Council's attention in order to support development of comments on the Federal Register notice.
- Related to offshore wind, the Committee and Advisory Panel discussion focused on siting issues in the GOM. The Advisory Panel reached consensus on a recommendation for transparent planning that involves the fishing industry and raised specific concerns with the unsolicited bid approach to leasing. While there was no Committee consensus on exactly how to frame the issue, in general members are seeking a transparent, data-driven, and inclusive siting process that accommodates a range of perspectives, including from the fishing industry.

#### DRAFT

- Related to policies on non-fishing impacts, the Committee and Advisory Panel expressed no disagreement with the proposed path forward and will await future updates from the PDT on the development of background documents for each of the three topics.

#### AGENDA ITEM #1: ANNUAL REVIEW OF COUNCIL RESEARCH PRIORITIES RELATED TO HABITAT AND OFFSHORE WIND

Ms. Bachman reminded the group about a recent change to the research priority setting process, where priorities are still set for five-year periods, but reviewed annually for additions, removals, or edits. The PDT reviewed the habitat and offshore wind related priorities on January 9. The PDT's suggestions were provided to the Committee and Advisors. The group discussed these priorities and made a series of recommendations.

One issue that received particular attention was benthic habitat sampling in conjunction with offshore wind development. This was discussed earlier in the month by the PDT. NMFS Habitat Conservation staff are working to provide more specific survey guidelines to BOEM, such that developers will be asked to collect data sufficient to enable NMFS to estimate impacts to EFH. In general, existing guidelines indicate benthic sampling to support engineering and design of the wind farm, but habitat maps (in the sense of living and non-living features at scales < 0.5 m) are not really the outcome of these surveys. A final version of the NMFS guidance should be forthcoming in the coming weeks and will be shared with the Council. The NMFS guidance was developed collaboratively and was a product of ongoing discussions with BOEM, developers and their survey contractors, and other experts. Motion 1 followed this discussion of the NMFS guidance.

Ms. Bachman noted that BOEM also has fishery survey guidance; while it is widely accepted that this guidance could be strengthened, to date, there have not been substantial efforts to review and suggest revisions. NMFS is beginning to look at the fishery guidance now. Somewhat related to this, NMFS NEFSC has a working group tasked with evaluating the effects of wind farms on NEFSC's fishery independent surveys. Overarching data and science coordination efforts related to offshore wind will be raised through discussions at the Responsible Offshore Science Alliance (ROSA), however surveys of lease areas are ongoing and will continue before coordinated guidance from ROSA is available.

#### Motion 1 (Minkiewicz/Wallace)

**It is the consensus of the Advisory Panel that habitat surveys of current and future wind energy areas should provide information to fishery managers and NMFS at a resolution and scale (spatial extent) useful for understanding effects on EFH and HAPCs. Specific applications might include the Fishing Effects Model and other models.**

**The Advisory Panel adopted the recommendation by consensus.  
The Committee adopted the Advisory Panel's recommendation by consensus.**

This motion should be general enough to be consistent with the forthcoming NMFS guidance on benthic surveys.

#### DRAFT

#### Motion 2 (Smolowitz/Casoni)

**The Advisory Panel recommends that seasonality (of habitat conditions, species distribution, oceanographic features, etc.) be identified as an important parameter under various research priorities.**

**The Advisory Panel adopted the recommendation by consensus.  
The Committee adopted the Advisory Panel's recommendation by consensus.**

Mr. Smolowitz noted that there is substantial variation in habitat features (benthic and oceanographic) as well as species distributions across seasons. He recommended that seasonality be added to the description of various research priorities. Staff will make these edits; likely this comment is pertinent to priorities 74, 78, 87, 88, and 91.

Jeff Kaelin suggested that priority 69 (existence value of corals and tradeoffs between coral protection and fishing) would be more appropriately identified as strategic (i.e. valuable, but not attached to an ongoing management action or one expected in the near term), rather than important (i.e. near term).

Priority #95 relates to evaluation of the effects of offshore wind on fishery surveys. Ms. Bachman understood that this priority was specific to NEFSC surveys that inform stock assessment, although this could be perhaps made more explicit. The Committee and Advisors agreed this was an urgent priority and recommended identifying multiple regions and potential wind technologies (fixed and floating) as this work is undertaken. They also suggested expanding the scope to encompass effects on fishery dependent data. It was noted that survey changes could have significant costs, for example if different vessels are required.

#### Motion 3 (Alexander/Bellavance)

**The Committee emphasizes the urgency of priority #95, not only for Southern New England/Mid-Atlantic but also for the Gulf of Maine. This priority should be expanded to encompass maintaining and developing fishery independent surveys, survey methodology, and fishery data streams, including socioeconomic impacts of these changes.**

**The Committee adopted the recommendation by consensus.  
The Advisory Panel adopted the Committee's recommendation by consensus.**

The inclusion of survey methodology in this motion refers to the idea that novel approaches (new survey vessels, methods, sampling designs) may be required for continued assessment of fishery resources in and around wind farms. Atlantic cod was identified as a focal species.

Building on the benthic survey discussion earlier in the morning, the issue of habitat surveys relative to array design was discussed. Concerns were raised that a relatively narrow sampling within sections of a lease area (i.e. mainly around locations targeted for turbine placement) can

**DRAFT**

make it difficult to adjust the design of the array later in the process to accommodate, for example, transit considerations.

**Motion 4 (Minkiewicz/Wallace)**

**Consensus of the Advisory Panel that the Council recommend to BOEM that at a minimum habitat surveys (as indicated in motion 1) are conducted of an entire wind lease area prior to selection of turbine locations.**

**The Advisory Panel adopted the recommendation by consensus.  
The Committee adopted the Advisory Panel's recommendation by consensus.**

Ms. Casoni noted that the wind resource is a primary driver for layouts. It was also acknowledged that design of the array within a lease area is an entirely different matter from determining location of the lease areas to begin with (this issue was raised again later for the GOM). The overlap between the horseshoe crab sanctuary and a wind energy area was cited as an example of where fisheries concerns did not override other siting considerations.

Dr. deFur asked Mr. Chiarella if BOEM has generally been responsive to NMFS concerns; he responded that they have, although perhaps not to the extent that they would like on some issues. Mr. Brogan asked if the Council had ever used the EFH consult provisions as a hook to really push an issue; Ms. Bachman was not aware of an example of this. Mr. Kaelin noted NMFS' EFH consultation letter on the Vineyard Wind project as a good attempt to make strong recommendations to BOEM related to fishery resources and habitats.

**AGENDA ITEM #2: EFP FOR THE GREAT SOUTH CHANNEL HMA**

Coonamessett Farm Foundation requested an exempted fishing permit to conduct a dredge-mounted camera survey (and undertake related work) in portions of the Great South Channel Habitat Management Area. CFF and GARFO have worked together since June to refine the proposal, and a forthcoming Federal Register notice (to be published January 27) will see public comments on issuance of the EFP. Mike Ruccio (GARFO SFD) described the EFP and changes made to the project since the original request was submitted. NMFS is recommending a phased approach, with a limited spatial area available for study during Phase 1 of the project. He had two questions for the Committee and Advisors:

1. Is the phase 1 work proposed appropriate in terms of sense and scale? Note that EFPs are usually issued for one year.
2. Is this responsive to the research request of the Council, and valuable to the Council/PDT?

Mr. Ruccio noted that one option would be to include any Council/Committee/PDT suggestions about the larger efficacy of research as part of Phase 2, while proceeding in the near term with Phase 1.

**DRAFT**

Ron Smolowitz provided some background on the project. The clam industry asked CFF to develop a research project. Tremendous unknowns acknowledged in the Council's research planning document, and the idea was to work through some of these. Before the HMA closed in April 2019, CFF completed five pilot trips on clam boats to see what technology would work and what information could be collected, to help design the proposal. Mr. Smolowitz noted that he had not been directly involved in much of the back and forth with GARFO staff, and that other researchers on the project had taken the lead. He raised a concern about the adaptability of the exemption pending resource conditions in the study area of the HMA, i.e. if they we go out in Phase 1 and don't find sufficient clams, then what?

Mr. Ruccio wasn't certain what the best approach would be – if there simply isn't sufficient biomass of clams in the study area, then might consider adjusting it. For example, extending or expanding the area if there appears to be biomass on the edge of the study area. He noted that they might need to take public comment again or could just work within existing EFP. He wondered if the Council would be willing to support expansion/adjustment of area if it seems necessary based on the resource. It isn't yet clear how adjustments might be made, if indicated, but NMFS would consider the impacts of dredging on the HMA, to ensure that major impacts would be unlikely to result from a modified approach.

Mr. Smolowitz asked if the full proposal would be provided with the announcement, since the broader project (not just the Phase 1/pilot) addresses more of the Council's research questions.

Terry Alexander expressed concern that the study area is too small to be workable. This was echoed by others in attendance.

Mr. Ruccio noted that monitoring would be required at the higher VMS polling rate envisioned in the Council's framework action, and that they intended to implement some sort of performance metric (data collection on at least 75% of tows). There would be CFF staff on some trips, with vessel crew enumerating the catch on other trips. Camera work is planned in the control areas.

Peter deFur suggested that the data to be collected during the pilot should be mapped to the Council's research questions, so as to provide a clear indication of the expected outcomes as related to these questions. He also asked about the sampling protocol for biological data, i.e. numbers, volume, weight, presence/absence?

Ron Smolowitz talked about what next steps will be in terms of potential data collection – he sees the effort as a habitat mapping project, not really a fishing impacts project. He asked what happened to idea of putting whole proposal out for comment and then having PDT evaluate progress and suggest adjustments mid-stream?

Peter Hughes agreed with the concerns about the small size of the study area. Are we answering all the questions if we do this? Seems problematic if low CPUE could stop the whole experiment.

**DRAFT**

Mike Ruccio commented that the revised Phase 1 project strikes at challenges and the need for compromise. Habitat mapping can be done in less impactful ways, but this project maps with a dredge mounted camera that will have an impact, thus the study area was limited. Would like to hear recommendations for process should adjustments be needed. Seems to NMFS to be a viable proof of concept approach.

Peter Hughes acknowledged that it would be great to have some more funding for this, but we don't, hence the dredge work.

Gib Brogan wondered if the exemption was an end run around OHA2 and the framework.

Ron Smolowitz responded that we have tons of data gaps that need to be filled. We don't have funding to look at these issues another way. Have tried.

Gib Brogan commented that it would be helpful in the project narrative to justify 120 trips, why that will create the compensation described. Describe finances/incentives. Why this is necessary? Mr. Smolowitz responded that in terms of cost, they worked backwards to estimate costs and then determine number of tows that would be needed to generate that amount of catch/money.

Drew Minkiewicz expressed frustration about OHA2 – the areas we were evaluating lacked data. Would be a real shame if we continue to not do research in these areas. Opportunity for growing our knowledge. Costs/impacts, yes, but shouldn't be at the cost of doing anything. Too long a process and a very pared down proposal. Should err on the side of learning; encourage NMFS to take that sort of mindset going forward.

Libby Etrie commented that in her view, the EFP is designed to help us learn more. Sometimes these EFPs are the only way to get the data – this is a balancing act. Sounds like this is a good balancing for now; should think more about process for modifying given that area seems a bit small.

Audience member Scott Lang commented that at the December 2018 Council meeting, industry said they would come back with research if the Council could come up with a research plan. There is no data. This compromise is too inflexible, doesn't provide enough continuity. Industry is funding this, Council designing it. If it is destined to fail before it starts, let's not do it. This is not a real compromise. Predictions have played out – layoffs in industry, loss of landings in New Bedford. If fishing there makes sense for the future, let's figure out how to do that. If you have money to pay for food/fuel/cameras, industry will go out and do the work.

Dave Wallace mentioned Nantucket Shoals clam survey conducted by the Science Center for Marine Fisheries. The finding was that clams are moving. Learned there are lots of rocks, most are buried, and Nantucket Shoals is a very dynamic area. Very few barnacle scars even. Disappointed with outcome of framework, and that NMFS wants to limit scope of EFP project to extent that it may fail.

**DRAFT**

The chair brought the discussion back to Mr. Ruccio's two questions. Hearing area is too small. What is minimum industry can deal with? What is the process for making this area bigger, if needed? Hearing we need data, need industry to fund it. What is the way forward?

Mr. Ruccio acknowledged that what is going out for comment is likely not going to answer all questions raised today. High bar – difficult to find that path forward. Found original proposal had too substantial an impact. Want to see if cost recovery aspect works. Don't see a big difference between fishing amounts within the area – once towed it is towed. Wanted to be able to speak on a more informed basis about how an expanded version of project will work. Options: full stop, back to drawing board, or start Phase 1 then begin conversations about Phase 2, perhaps with dynamic back and forth with PDT/committee.

Peter deFur suggested that the Chair work with AP chair and Ms. Bachman to develop a list of comments made and points raised and submit to the Council as our discussion and not try to reach any consensus. Action will occur on EFP regardless of Council input. Ms. Etrie and Mr. Bellavance agreed with this.

Question to industry - is this project feasible as is? Industry members Louie Legace and Allen Rencurrel acknowledged that area size was a concern, but that they supported issuance of the EFP as a first step to gathering needed data. Mr. Rencurrel noted that he would like to move ahead for now, get the ball rolling. See what we can do with the area available.

Drew Minkiewicz said he would like to see research being done to learn more about areas and impacts. Dave Wallace recommended that NMFS should go forward with compromise proposal. If industry is willing to do it, we should support it.

Overall, the Committee agreed to document the concerns raised and provide those to the Council to assist in the formulation of comments.

#### **AGENDA ITEM #3: OFFSHORE WIND UPDATES AND DISCUSSION**

Note: Many research-related offshore wind issues were discussed earlier in the day under Agenda Item #1.

Ms. Bachman presented slides on various offshore wind topics (a similar presentation will be given at the Portsmouth Council meeting). In terms of project updates, multiple Construction and Operations Plans are under review at BOEM or should be provided to BOEM in the near future. Once these are deemed sufficient, this clears the way for BOEM to publish a Notice of Intent to prepare an EIS for the project. The Council will be able to comment on the content of the EIS at the NOI stage and will need to consider how much time to devote to this vs. other work. She noted that Brian Hooker will address the Council on the topic of the SEIS for the Vineyard Wind project next week; Gib Brogan asked if the forthcoming North Atlantic Right Whale Biological Opinion was being considered by BOEM during development of the SEIS (an answer was not available during the meeting, but yes, they are considering it). Ms. Bachman emphasized that the MAFMC/NEFMC joint offshore wind webpage is continually updated, with a recently added section on comment opportunities.

#### **DRAFT**

There was a relatively lengthy discussion of the GOM regional task force meeting and the next steps for wind development in the region. A few Committee and Advisory Panel members were in attendance at that meeting, held in NH on December 12. Audience member John Williamson commented that he felt the task force was very oriented towards fisheries. Ron Smolowitz asked how siting it going to work; there was then discussion of the solicited vs. unsolicited bid process, and the different types of areas identified (Planning and Request for Information Areas, which are optional steps, followed by Call and Wind Energy Areas, which are required steps). The group continued to discuss GOM siting issues, and the Advisory Panel agreed to the following:

#### **Motion 5 (Kaelin/Wallace)**

**That the Council recommend to BOEM that the planning process for wind energy areas in the GOM should be transparent (including no unsolicited bids) and involve the fishing community.**

**The Advisory Panel agreed to the motion by consensus.**

The Committee was generally supportive of the Advisory Panel's statement but couldn't reach agreement on the best language with which to convey a recommendation. Some draft language, discussed by the group:

- *That the Council recommend to BOEM that the planning process for wind energy areas in the GOM should be transparent (no unsolicited bids) and involve the fishing community throughout the process with meaningful input on delineation of Planning, RFI, Call, and then Wind Energy Areas.*
- *The Committee recommends that the Council consider any and all avenues to advise BOEM on the siting of Wind Energy Areas.*

Members suggested asking BOEM what would be the best mechanisms for meaningful Council engagement. Lou Chiarella suggested one path forward would be to recommend specifically how fish/fisheries information should be used to support area identification.

Audience member Patrick Paquette cautioned that the Council should strive for consistency in terms of thinking of the effects of various activities on the Council's habitat management areas. For example, if the Council is prepared to recommend that wind farms not be installed in HMAs, is that consistent with allowing exempted fishing in HMAs? Audience member John Williamson emphasized that it is important to be influential early in the siting process, as further down the road after the site assessment has been completed and the EIS drafted it is more costly to adjust project layouts.

Ms. Bachman reviewed a range of recent and ongoing activities of the Responsible Offshore Development Alliance. Elizabeth Marchetti, Lane Johnston, and Peter Hughes conveyed their enthusiasm about two recent workshops to identify layout ideas for Equinor and Ørsted projects in the NY Bight. These seem to be a good model for data gathering. Speaking for Equinor, Ms. Marchetti noted that the feedback was provided to their engineers for review. The Empire Wind

#### **DRAFT**

site was surveyed in such a way that it will be possible to adjust the layout later without gathering additional engineering data.

Finally, Ms. Bachman noted that the Coast Guard's Massachusetts Rhode Island Port Access Route Study should be available soon.

#### **AGENDA ITEM #4: DEVELOPMENT OF COUNCIL POLICIES ON NON-FISHING IMPACTS TO HABITAT**

Ms. Bachman reviewed recent work on efforts to develop policies for non-fishing impacts to habitat. The topics being developed are floating offshore wind, submarine cables, and aquaculture. The policies are intended to be a compilation of best management practices, and, where appropriate, value judgements, to inform these types of development, both near and offshore. They can be applied when drafting Council comments on specific projects and can be referenced by NMFS staff as they conduct EFH consultations. They also serve as a communication tool to convey Council's perspectives on these activities and preparing them will be an educational exercise for the Council and its stakeholders.

To the last point, an initial step before drafting the actual policies is to develop a background on these three topics. When MAFMC created similar policy statements they created background information documents as a first step, and these seems an appropriate step for NEFMC to follow as well. The PDT, with the participation of Advisory Panel and Committee members as well as outside experts will coordinate these background documents. They are intended to be less than ten pages each, and will include sections describing the activity, potential effects on EFH, potential effects on managed species, and potential interactions with other activities, including fishing. Outlines for each document were developed during January. Over the next two months, PDT members and others will continue to assemble information and begin to draft sections of these documents. Ron Smolowitz suggested looking at previous NEFMC Aquaculture Committee work. Ms. Bachman will check in with a progress update during March to see how the work is proceeding and estimate a timeline for completion. Some sort of review/information sharing meeting with the Committee, Advisors, and others will likely be the appropriate next step, after the background documents are completed.

#### **AGENDA ITEM #5: NHRA UPDATE, OTHER BUSINESS**

Ms. Bachman gave a quick update on the Northeast Regional Habitat Assessment or NHRA, a collaborative effort between the New England and Mid-Atlantic Councils, NOAA, and other partners to "describe and characterize estuarine, coastal, and offshore fish habitat distribution, abundance, and quality in the Northeast using a partnership driven approach". The three-year project has been underway for just over six months. Recent efforts include a data inventory, initial exploration of habitat suitability models for regional fishery species, development of metadata for spatial data sources, and assembly of species habitat profiles (building, when available, on EFH source documents and other resources). The NHRA teams are fostering partnerships with other assessments in terms of data gathering to avoid duplication of efforts and develop a shared understanding of caveats and applications for different sources. Team members are also working to identify related modeling projects and other analyses, so that we can compare results and possibly borrow ideas for how to package and present the results of NHRA.

#### **DRAFT**

The assessment originated with the MAFMC, which was beginning to do a 5-year EFH review, and realized that they and various partners would benefit from a broader regional habitat assessment. Partner organizations supported a broader approach, and planning teams, a steering committee, and finally work teams were assembled during 2018-2019, with the assessment formally beginning after steering committee approval of the workplan in July 2019. NHRA will include the elements of a 5-year EFH review and have applications for Council EFH work, but will have many other uses as well. Efforts to present results are just beginning to be explored, but the vision is to serve up spatial data products on the regional ocean data portals.

The meeting adjourned at approximately 4:10 p.m.





**Daniel J. McKiernan**  
*Acting Director*

# *Commonwealth of Massachusetts*

## **Division of Marine Fisheries**

251 Causeway Street, Suite 400

Boston, Massachusetts, 02114

(617) 626-1520

fax (617) 626-1509



**Charles D. Baker**  
*Governor*

**Karyn E. Polito**  
*Lieutenant Governor*

**Kathleen Theoharides**  
*Secretary*

**Ronald S. Amidon**  
*Commissioner*

**Mary-Lee King**  
*Deputy Commissioner*

January 28, 2020

### Marine Fisheries Advisory

## **DMF to Host Scoping Meeting on State Response to Anticipated Changes to Federal Atlantic Large Whale Take Reduction Plan Affecting Trap Fisheries**

The Division of Marine Fisheries (DMF) has scheduled two scoping meetings to discuss the state's response to anticipated changes to the federal Atlantic Large Whale Take Reduction Plan (ALWTRP). The meeting schedule is as follows:

**6PM**  
**February 18, 2020**  
**Admiral's Hall, MA Maritime Academy**  
**101 Academy Drive**  
**Buzzard's Bay, MA 02532**

**6PM**  
**February 19, 2020**  
**DMF's Annisquam River Field Station**  
**30 Emerson Avenue**  
**Gloucester, MA 01930**

In response to recent population trends, NOAA Fisheries' Atlantic Large Whale Take Reduction Team (TRT) has been working to amend the ALWTRP to consider federal regulatory adjustments to reduce the risk of serious injury and mortality posed by trap fishing gear, specifically vertical buoy lines, to endangered right whales that may become entangled therein. The TRT subsequently endorsed a preliminary framework that established a 60% risk reduction target. Over the course of the last year, DMF staff has been working with NOAA fisheries to provide updated data analyses and regulatory advice. The purpose of this meeting will be to review NOAA Fisheries analyses regarding how the state can achieve this federally imposed risk reduction target. Comments received will help DMF engage on federal rule making moving forward.

Right whales are a critically endangered species. They seasonally migrate into Massachusetts waters and aggregate in Cape Cod Bay to feed on zooplankton during the late-winter and early-spring. In recent years about 65% of the known right whale population has been seasonally observed in our waters. The entanglement of whales in fixed fishing gear, particularly vertical buoy lines, is a substantial source of human-caused mortality.

Please note, starting February 1, 2020, all DMF advisories will be posted through our new email subscription service. To ensure your subscription with DMF continues, we kindly ask you review your [subscriber preferences](#). With this new service you can customize emails based on your personal interests such as newsletters, commercial and/or recreational fishing advisories, event updates and more. Thank you for your continued interest in DMF.

For more information regarding the management of protected species, please visit our [website](#).



# SERIOUS ABOUT SAFETY

LRSE.COM | 401-816-5400

590 FISH RD, TIVERTON, RI 02878  
 181 OLD COLONY AVE, UNIT A, BOSTON, MA 02127  
 55 STATE ST, NARRAGANSETT, RI 02882



SALES • SERVICE • TRAINING • RENTAL • OUTFITTING • PICKUP + DELIVERY

## Safety Equipment Servicing

Life Raft + Survival Equipment has been selling and servicing all major brands of Life Rafts, EPIRBs/PLBs, Life Jackets, Immersion Suits, and Man Overboard Equipment since 1983.

We offer pickup and delivery to over 20 locations throughout the Northeast.

CALL FOR GREAT PRICING.

## North East Safety Training

NEST, a division of LRSE, offers hands-on Basic, Advanced, and Customized Safety Training Courses, Monthly Drill Conducting, First Aid/CPR/AED Courses and Vessel Inspections.

VISIT OUR WEBSITE TO LEARN MORE.

-  LIFE RAFTS
-  EPIRBs + PLBs
-  LIFE JACKETS
-  IMMERSION SUITS
-  MAN OVERBOARD
-  PICKUP + DELIVERY

## COMMERCIAL LIFE RAFTS

Elliot, Zodiac, Crewsaver, Revere, Viking



## FIBRELIGHT LADDERS

Man Overboard Recovery Cradle, Self Recovery Ladder



## IMMERSION SUITS

Imperial



## EPIRBs

ACR V4



## FIRETKO®

Fire Suppression Tool



## LIFE JACKETS

Mustang





# NEW ENGLAND PROPELLER, INC.

Distributor of Michigan Propellers

**Inboard • Outboard**



Next Generation 3D Computerized Propeller Analyzer  
Computerized Dynamic Balancing

## Marine Fuel Tanks

Custom Fabricated & Tested to U.S.C.G Specifications  
*By Capeway Welding*

- Marine Propeller Sales & Repairs - **4000 Props in Stock**
  - Sierra Engine Parts for All Outboards & IOs
- CDI Electronics • Camp & Godfrey Zincs • NGK Spark Plugs
  - Duramax Cutless Bearings • Spurs Line Cutters
- PSS Dripless Shaft Seals • Buck Algonquin - Struts, Rudders & Stuffing Boxes
  - S/S Shafting • Drive Savers • Globe Impellers



9 Apollo Eleven Rd., Plymouth, MA 02360

Tel: 508-747-6666 800-635-9504 - [neprop.com](http://neprop.com)







**AQUAMESH®**  
is celebrating

**40**

**YEARS**  
of marine excellence

*Thanks to all of you for the continued  
success of AQUAMESH®*

1.800.762.6374 • sales@riverdale.com • www.riverdale.com



# 20 FITNESS TIPS FOR MEN

**FOR your HEALTH**

*Research shows that extra kilos mean a shorter life for men.*

*It's time to start turning back the clock and here are some tips!*

## 1. FIRST, HAVE A CHAT WITH YOUR GP

As we get older, it's always a good idea to check in with our General Practitioners (GPs) for regular health check-ups. GPs can check your blood pressure, cholesterol and heart health and also measure your waistline to ensure you're in a healthy condition before kick starting any new fitness programs.

## 2. CUT DOWN ON ALCOHOL

As you get older, different health issues may develop as you age that alcohol can affect in different ways. Cutting back on alcohol consumption means you're at less risk of developing long-term health problems such as cancer, heart disease or liver cirrhosis (scarring). You might even lose weight, have more energy and feel better.

## 3. MOTIVATE YOURSELF

Need a reason to stay fit? How about a longer life? For men, fitness level can predict length of life even better than body mass index (BMI) can, according to a study of more than 14,000 men. As a man's fitness improved, his risk of death from all causes dropped 15 percent and his risk of death from heart disease was reduced by 19 percent.

## 4. TRY AND STICK TO

### THE EXERCISE GUIDELINES

It's recommended that older adults do at least 30 minutes of moderate intensity physical activity on most, preferably all, days. If 30 minutes seems too much to you, don't worry, as some activity, however light, is better for your health than none at all. This could be walking around the block, doing some gardening, or even playing some backyard cricket.

## 5. DON'T BE AFRAID TO ASK FOR HELP

Not too sure where to start when it comes to exercising? No worries! Speak to an Accredited Exercise Physiologist. Basically, an exercise physiologist specialises in designing and delivering safe and effective exercise programs for all populations. Having a chat with one before undertaking any exercise is a smart move.

## 6. PUT THE PEDAL TO THE METAL

Cycling is mainly an aerobic activity, which means that your heart, blood vessels and lungs all get a workout. You will breathe deeper, sweat and experience increased body temperature, which will improve your overall fitness level.

## 7. TAKE THE STAIRS

Stair climbing burns more calories than a traditional walk and increases your chance to achieve weight loss. It can help to improve your energy, increase the function of your immune system and lower your risk for diabetes, high blood pressure, osteoporosis and heart disease.

## 8. KEEP THE WEIGHTS ON

No equipment, no worries. Bodyweight exercises like squats, push-ups, or step ups will help to increase muscle tone, maintain sound strength, build bone density, maintain a healthy weight, optimize metabolic function, and reduce the risk of injury, falls and fatigue. It is recommended a minimum of two sessions per week be conducted to achieve the benefits of this training.

## 9. RESISTANCE IS KEY

Resistance training is one of the most effective ways to maintain muscle mass as we age. There's a wide range of benefits of engaging in resistance training.

## 10. KEEP IT SOCIAL

A social exercise group class may not immediately ease your arthritis or make your shoulder range

**B** *LONG-LASTING,  
AFFORDABLE  
LOBSTER BAIT!* **B** **essy Bait** **LLC**

All Natural Salted Hairless Cowhide

[www.bessybait.com](http://www.bessybait.com)

Available in 30 gal. barrels and 5 gal. pails

CALL: 603.300.2846 or 603.300.2849

EMAIL: [info@bessybait.com](mailto:info@bessybait.com)

FOR SALE BY APPOINTMENT ONLY AT

155 Batchelder Rd., Seabrook, NH 03874





amazing but if you have a good time doing it, you'll feel better. Feeling better means you'll be more likely to go back again to help kick start those health benefits. Even exercising with a buddy can help keep you accountable ensuring you both get your body moving and heart pumping.

**11. JUST KEEP SWIMMING**

Hydrotherapy is a type of exercise therapy done in a heated pool. It has a wide range of benefits and is used to target and treat a variety of conditions. The use of gentle, controlled movements in warm water (heated up to 31-35 degrees) allows people to steadily progress their range of movement. It's also a safe, comfortable and often enjoyable environment.

**12. DON'T NEGLECT THE CORE**

Core strength is more than just working on the six-pack. These muscles support the spine through flexion, extension and rotation, and incorporate the pelvic floor. Learning how to properly engage and activate these muscles daily will help to prevent injury during daily activity, prevent incontinence, boost sexual health, and improve pelvic stability.

**13. DON'T FORGET NUTRITION**

Good nutrition plays a key role in healthy ageing and quality of life, especially when there are many physiological changes associated with the ageing process. When it comes to providing adequate nutrition, making every mouthful count is key, and speaking with an Accredited Practising Dietitian can sometimes be the best option if you have any concerns.

**14. AIM FOR THE GREEN**

Did you know that simply by playing golf you can extend your life by 5 years in comparison to non-golfers? The research is piling up on the wide range of health benefits you receive from playing golf including improved longevity and cardiovascular fitness, reduced risk of chronic conditions, positive mental health and boosted strength and balance.

**15. STRETCH IN FRONT OF THE TV**

Can't make it to a gym class or out for a run? Stretch in between your favorite tv show or footy game. Resistance stretching (also known as power band stretching) allows you to increase your range of motion and keeps your body moving correctly.

**16. HOLD ONE-EAR AND STAND ON ONE LEG**

Balance exercises are so important for older men over the age of 55 to help enhance proprioception awareness, coordination, maintain muscle activity and tone, and prevent against falls and the resulting injuries.

**17. TRY NEW THINGS**

There is no one perfect workout or exercise; everyone is different. There's a wide selection of exercise or physical activity you can undertake from swimming, dancing, cycling, walking the dog, the list goes on! Creating an exercise habit is difficult, but finding one you enjoy can make it easier to come back to – and more likely you'll stick to your program.

**18. DON'T WORRY ABOUT RUNNING GIVING YOU BAD KNEES**

The reality is that running is hard on your body but that's why it

can impact our health in such profound, positive way. Our body adapts and evolves to physical stress if it is dosed out appropriately and investing some money in the right pair of shoes helps too.

**19. LISTEN TO YOUR HEART (RATE)**

Exercise is a great way to keep your heart happy and healthy and it's a good idea to pay attention to your heart rate during exercise. For adults, moderate intensity exercise is about 50%-65% of your age-predicted heart rate maximum. Your maximum age-predicted heart rate is calculated as follows: Age-predicted HR max = 220 – age. For example, if you're 50 years old, your maximum HR would be approximately 170 (220 – 50).

**20. REMEMBER TO TAKE TIME TO RECOVER**

Your body won't recover quite as quickly as it once did when you were younger, so it's important to take it easy and to allow yourself some recovery time. Whenever we exercise, the body undergoes change to adapt to the stress that we place on it. The by-product of these adaptations can include muscle soreness and fatigue and reduced muscle strength and power. Resting your body is essential by getting plenty of sleep and staying hydrated. <https://exerciseright.com.au/20-fitness-tips-for-older-men/>

**Make cleanup easy and fast.**

# Blast Away!

**Onboard Pressure Washers**  
5.6 GPM @ 3,500 PSI

*Our pressure washers come with everything you need, including 50' hose and wand with turbo nozzle.*

Belt Driven                      Hydraulic

Salt or Fresh Water

**Coastal Hydraulics, Inc.**  
603-474-1914 • sales@coastalhyd.com  
www.coastalhyd.com  
28 Route 286, Seabrook, NH

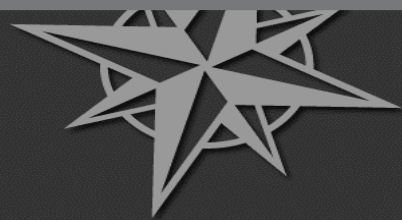

# Rose Marine

Gloucester, MASS [www.rosesmarine.com](http://www.rosesmarine.com)

## 877-283-3334

### Sales and Service of Hydraulic Components

We will customize a hydraulic hauling or power-steering system to fit your exact needs.

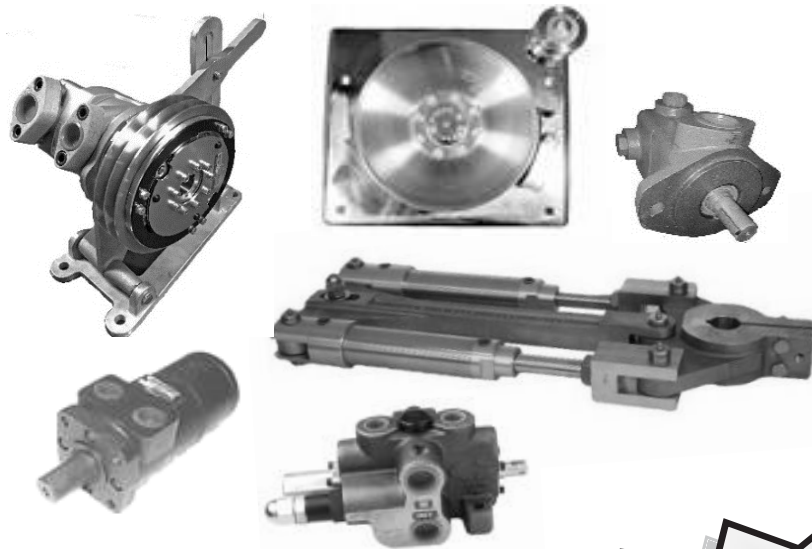

Authorized SEASTAR Solutions (FORMERLY Teleflex) Repair Facility for the Northeastern U.S.



SEASTAR SOLUTIONS®

**Hynautic**

*Capitano*™



*Same-Day Service Available on most Emergency Repairs!*

Complete Line of **Johnson Pump**® Pumps & Parts



Clutch Driven



Engine Cooling



Hydraulic Driven  
*Sized to the flow rate to fit your boat.*

Complete Line of **PACER** Pumps & Parts

**PACKLESS SEALING SYSTEM**  
**SHAFT SEAL**



**Stocking Distributor**

Combination Shaft Zinc & Line Cutters



Shaft Sizes  
3/4" to 2-1/4"



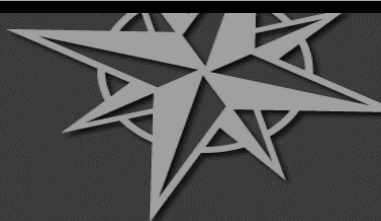

Rose Marine

Gloucester, MASS [www.rosesmarine.com](http://www.rosesmarine.com)

**877-283-3334**

Aqualoy Stainless Propeller Shafts & Accessories



Largest stock of **Aqualoy** Stainless Prop Shafting on the East Coast  
With *Emergency* turn-around time available.

Call or e-mail Peter Tetrault for a price on your next shaft.  
[peter.tetrault@rosesoil.net](mailto:peter.tetrault@rosesoil.net)



Quality Oil Coolers  
Made in the U.S.A.

- All Seamless Tubing
- High pressure available
- 90/10 copper-nickel
- 2" to 5" Dia. Body in stock



- Stainless Steel Wrapped
- Teflon Core
- Super Low friction

Ask for the "GREEN MARINE" cable

**KOBELT**  
Controls



Anchor Flush Mount  
Hatches

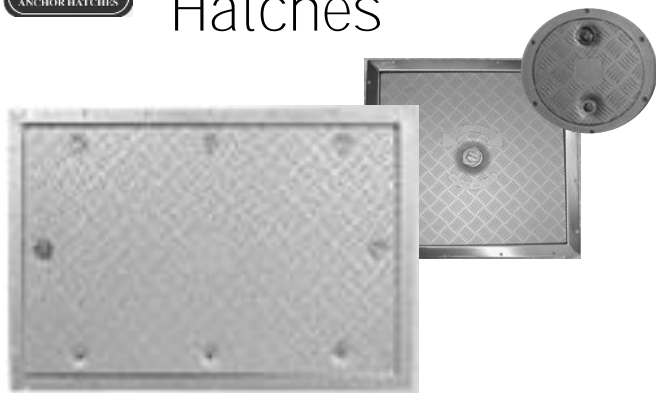

**Mufflers and Exhaust  
Components**



Stainless Steel Mufflers  
And Accessories  
2" - 8" inlet size in stock



# 15 Surprising Facts About Winter Weather

*Whether you enjoy bundling up in your coziest gear or are already counting down the days until spring, here are 15 facts about what's happening outdoors this time of year.*

## 1. IT SOMETIMES SNOWS WHERE YOU LEAST EXPECT IT.

You wouldn't be shocked to see snow on the ground of Siberia or Minnesota when traveling to those places during the winter months. But northern areas don't have a monopoly on snowfall—the white stuff has been known to touch down everywhere from the Sahara Desert to Hawaii. Even the driest place on Earth isn't immune. In 2011, the Atacama Desert in Chile received nearly 32 inches of snow thanks to a rare cold front from Antarctica.

## 2. SNOWFLAKES COME IN ALL SIZES.

The average snowflake ranges from a size slightly smaller than a penny to the width of a human hair. But according to some unverified sources they can grow much larger. Witnesses of a snowstorm in Fort Keogh, Montana in 1887 claimed to see milk-pan sized crystals fall from the sky. If true that would make them the largest snowflakes ever spotted, at around 15 inches wide.

## 3. A LITTLE WATER CAN ADD UP TO A LOT OF SNOW.

The air doesn't need to be super moist to produce impressive amounts of snow. Unlike plain rainfall, a bank of fluffy snow contains lots of air that adds to its bulk. That's why what would have been an inch of rain in the summer equals about 10 inches of snow in the colder months.

## 4. YOU CAN HEAR THUNDERSNOW WHEN THE CONDITIONS ARE RIGHT.

If you've ever heard the unmistakable rumble of thunder in the middle of a snowstorm, that's not your ears playing tricks on you. It's likely thundersnow, a rare winter weather phenomenon that's most common near lakes. When relatively warm columns of air rise from the ground and form turbulent storm clouds in the sky in the winter, there's potential for thundersnow. A few more factors are still necessary for it to occur, namely air that's warmer than the cloud cover above it and wind that pushes the warm air upwards. Even then it's entirely possible to miss thundersnow when it happens right over your head: Lightning is harder to see in the winter and the snow sometimes dampens the thunderous sound.

## 5. SNOW FALLS AT 1 TO 6 FEET PER SECOND.

At least in the case of snowflakes with broad structures, which act as parachutes. Snow that falls in the form of pellet-like graupel travels to Earth at a much faster rate.

## 6. IT DOESN'T TAKE LONG FOR THE TEMPERATURE TO DROP.

Don't take mild conditions in the middle of January as an excuse to leave home without a jacket. Rapid City, South Dakota's weather records from January 10, 1911, show just how fast temperatures can plummet. The day started out at a pleasant 55°F, then over the course of 15 minutes a wicked cold front brought the temperature down to 8 degrees. That day still holds the record for quickest cold snap in history.

## 7. THE EARTH IS CLOSEST TO THE SUN DURING THE WINTER.

Every January (the start of the winter season in the northern hemisphere) the Earth reaches the point in its orbit that's nearest to the Sun. Despite some common misconceptions, the seasonal drop in temperature has nothing to do with the distance of our planet to the Sun. It instead has everything to do with which direction the Earth's axis is tilting, which is why the two hemispheres experience winter at different times of the year.

## 8. MORE THAN 22 MILLION TONS OF SALT ARE USED ON U.S. ROADS EACH WINTER.

That comes out to about 137 pounds of salt per person.

## 9. THE SNOWIEST CITY ON EARTH IS IN JAPAN.

Aomori City in northern Japan receives more snowfall than any major city on the planet. Each year citizens are pummeled with 312 inches, or about 26 feet, of snow on average.

## 10. SOMETIMES SNOWBALLS FORM THEMSELVES.

Something strange happened earlier this year in northwest Siberia: Mysterious, giant snowballs began washing up on a beach along the Gulf of Ob. It turns out the ice orbs were formed naturally by the rolling motions of wind and water. With some spheres reaching nearly 3 feet in width, you wouldn't want to use this frozen ammunition in a snowball fight.

## 11. WIND CHILL IS CALCULATED USING A PRECISE FORMULA.

When the weatherman reports a "real feel" temperature of -10 degrees outside, it may sound like he's coming up with that number on the spot. But wind chill is actually calculated using a complicated equation devised by meteorologists. For math nerds who'd like to test it at home, the formula reads:  $Wind\ Chill = 35.74 + 0.6215T - 35.75(V^{0.16}) + 0.4275T(V^{0.16})$ .

## 12. CITIES ARE FORCED TO DISPOSE OF SNOW IN CREATIVE WAYS.

When snow piles up too high for cities to manage, it's usually hauled away to parking lots or other wide-open spaces where it can sit until the weather warms up. During particularly snowy seasons, cities are sometimes forced to dump snow in the ocean, only to be met with criticism from environmental activists. Some cities employ snow melters that use hot water to melt 30 to 50 tons of snow an hour. This method is quick but costly—a single machine can cost \$200,000 and burn 60 gallons of fuel in an hour of use.

## 13. WET SNOW IS BEST FOR SNOWMAN-BUILDING, ACCORDING TO SCIENCE.

Physics confirms what you've likely known since childhood: Snow on the wet or moist side is best for building your own backyard Frosty. One scientist pegs the perfect snow-to-water ratio at 5:1.

## 14. SNOWFLAKES AREN'T ALWAYS UNIQUE.

Snow crystals usually form unique patterns, but there's at least one instance of identical snowflakes in the record books. In 1988, two snowflakes collected from a Wisconsin storm were confirmed to be twins at an atmospheric research center in Colorado.

## 15. THERE'S A DIFFERENCE BETWEEN FREEZING RAIN AND SLEET

Freezing rain and sleet can both have scary effects on driving conditions, but their formations differ in some key ways. Both types of precipitation occur when rain formed in warm air in the sky passes through a layer of cold air near the ground. Thicker layers of cold air create sleet, a slushy form of water that's semi-frozen by the time it reaches the Earth. Thinner layers don't give rain enough time to freeze until it hits the surface of the ground—it then forms a thin coat of ice wherever it lands. <https://www.mentalfloss.com/article/89881/15-surprising-facts-about-winter-weather>

## RECIPE *of the* MONTH



### Lobster Avocado Toast

#### Ingredients

- 2 slices fresh whole grain bread
- 5 oz. of fresh cooked lobster meat
- 2 fresh avocados
- 1 vine ripe tomato
- ½ cup red onion, diced
- 1 tsp lemon juice
- 2 small fresh jalapenos, sliced thin

#### Directions:

- Toast grain bread slices to light brown toast.
- Prepare fresh avocado spread by mixing avocado, chopped tomatoes, diced red onion, and lemon juice. Smash gently and spread on toast.
- Top fresh avocado with lobster meat.
- Layer thinly sliced jalapeno over lobster meat.
- Sprinkle with fresh chives and serve



### ATLANTIC OFFSHORE LOBSTERMEN'S ASSN.

Offshore lobster industry advocate since 1972  
Pro-active, common sense, member driven approach

#### WHAT WE DO

- ◆ Helped to establish Limited Entry in Area 3 lobster fishery
- ◆ Lobbied for Area 3 historic participation & transferability
- ◆ Secured funds to offset costs of sinking groundline
- ◆ Advocated for Jonah Crab Fishery Management Plan
- ◆ Led industry's response to the marine monument
- ◆ Strong advocate of common sense whale rules
- ◆ Leadership roles on the ASMFC's Lobster Board, Lobster and Jonah Crab Advisory Panels, and Area 3 LCMT
- ◆ NEFMC's Habitat Committee and NOAA Fisheries' Atlantic Large Whale Take Reduction Team member

#### 2020 ISSUES

Right Whales	100% Vessel Reporting
Trap Cap Regulations	Marine Monument
Wind Energy	Bottom Sharing

Recruiting offshore lobstermen and associated businesses  
New voices to help guide us in the right direction for the industry

**Join Today**

To Learn More, Contact Heidi Henninger

**Join Today**



**THE Specialists**  
FROM BUOY TO TRAP

*Built the Best, Built to Last,  
Built Your Way.*

## PROVEN PERFORMERS! Rockbottom Runners



Our precision formulation and process has been refined over the years to provide the optimum balance of strength and flexibility... – and the vise test shows it

Over **20 YEARS** of fishing;

Well over **HALF A MILLION** sold



*Could you do this with any other concrete runner?*

**LiteLoad**

SOLID STEEL CORE  
- TOUGH POLYMER COATING



Over **6 YEARS** of fishing.

Over a **QUARTER MILLION** sold

**GORILLA WOOD**  
RUNNERS

OCEAN-TESTED for years... aircraft carrier decking and pilings in the marine borer intense Panama Canal Zone.



*The toughest species of junglewood we've found ... and the only kind we sell.*

**We are constantly listening to our customers:  
Your feedback + continuous improvement  
= proven reliability**

#### Here to serve you!

**Jerry Wadsworth** (207) 542-0842 jerryw@friendshiptrap.com  
**Jimmy Emerson** (207) 483-6555 jemerson@friendshiptrap.com  
**Mike Wadsworth** (207) 542-0841 mikew@friendshiptrap.com

**Friendship Office:** (800) 451-1200; (207) 354-2545

**Columbia Falls Office:** (800) 339-6558

Visit our website: [www.friendshiptrap.com](http://www.friendshiptrap.com)





## Join Us for These Upcoming Programs

### First Aid and CPR Training

**Chatham** - February 24, 2020 - 2:00 p.m. - 6:00 p.m.  
Chatham Community Center, 702 Main Street, Chatham, MA

**Plymouth** - February 25, 2020 - 9:00 a.m. - 1:00 p.m.  
FPSS Plymouth, 139 Court St., Plymouth, MA

**Gloucester** - February 28, 2020 - 10:00 a.m. - 2:00 p.m.  
FPSS Gloucester, 2 Blackburn Center, Gloucester, MA

### Vessel Stability

**Chatham** - February 4, 2020 - 9:00 a.m. - 4:00 p.m.  
Community Center, 702 Main Street, Chatham, MA

**Gloucester** - February 14, 2020 - 10:00 a.m. - 5:00 p.m.  
USCG Station, 17 Harbor Loop, Gloucester, MA

**New Bedford** - February 18, 2020 - 9:00 a.m. - 4:00 p.m.  
FPSS New Bedford, 38 Bethel St., New Bedford, MA

**For more information, or to register for a training, contact a Navigator in your area:**

### Chatham

[Serving the Cape & the Islands]  
Morgan Eldredge and Shannon Eldredge  
(508) 237-9402

### Gloucester

[Serving the North Shore]  
Nina Groppo and Maria Carpenter  
(978) 282-4847

### New Bedford

[Serving the South Coast]  
Deb Kelsey (508) 884-6661, Jenny Amaral and Rob Jardin (508) 991-3043

### Plymouth

[Serving Boston & the South Shore]  
Lori Caron (781) 635-0011

### Need Help with Health Insurance?

You may still be eligible to enroll. Contact a Fishing Partnership Navigator for assistance with health insurance coverage, understanding your insurance benefits, or finding a doctor.

### About Us

The mission of Fishing Partnership Support Services is to improve the health, safety and economic security of fishing families. Founded in 1997, the Partnership is headquartered in Burlington, MA, and maintains offices in the Massachusetts port communities of Gloucester, Plymouth, New Bedford and Chatham. For more information visit [www.fishingpartnership.org](http://www.fishingpartnership.org).

[In association with Massachusetts Fishermen's Partnership]





Photo credit: Steve Kennedy

**FISHING PARTNERSHIP****SUPPORT SERVICES****SAVE THE DATE!****NEW BEDFORD FISHING COMMUNITY  
CELEBRATION & HEALTH FAIR**

A Day of Fishing Community & Family Fun!

February 8 / 10:00 a.m. - 4:00 p.m.

(Snow Date: February 29)

Kilburn Mill, 127 W. Rodney French Boulevard, New Bedford

Fishermen & Industry Representatives | Prizes | Food | Seminars  
Health Insurance Enrollment | Games | Self Care/Health Screenings

**About Us**

The mission of Fishing Partnership Support Services is to improve the health, safety and economic security of fishing families. Founded in 1997, the Partnership is headquartered in Burlington, MA, and maintains offices in the Massachusetts port communities of Gloucester, Plymouth, New Bedford and Chatham. For more information visit [www.fishingpartnership.org](http://www.fishingpartnership.org).

[In association with Massachusetts Fishermen's Partnership]

# MLA CLASSIFIEDS

PLEASE CHECK YOUR AD TO MAKE SURE IT IS CURRENT  
Send ads to [tracey.abboud@lobstermen.com](mailto:tracey.abboud@lobstermen.com)

*Ads will run for 5 months & then automatically be deleted unless you call the MLA office to renew your ad. 781-545-6984 or email ads to [tracey.abboud@lobstermen.com](mailto:tracey.abboud@lobstermen.com)*

Classified ads are a free benefit to MLA Members and Non-members are a flat \$25.00

*\*All ads are subject to review prior to placement*

**AD #1 (2/20) FOR SALE- PRICE REDUCED-** 1950 Buick Special- 55,000 original miles Approx; 75% restored Call/info 781-733-1498 / email [lggyburton@aol.com](mailto:lggyburton@aol.com) \$6,500 OBRO

**AD#2 (2/20) HELP WANTED-** Fishing Boat/ Scituate MA-Must be reliable/drug/ alcohol free w/ valid drivers license & own transportation. % of pay based on experience. E-mail [Hiflyer2@verizon.net](mailto:Hiflyer2@verizon.net)

**AD#3 (2/20) FOR SALE-** 40 ft. Stanley Greenwood fiberglass over wood. 220 John Deere engine 14 in. pot hauler-power inverter- Microwave in fishhold/ liferaft/Epirb more info call 603-714-2247

**AD#4 (1/20) FOR SALE -** Hydraulic Components, parts and service. Pumps, Motors, Valves and Accessories. Hydraulic Hoses made while you wait. Great Prices - Same day service (in many cases)- Wide selection of in-stock items. Rebuilt items are occasionally available. Call ROSE MARINE, Gloucester, MA 877-283-3334

**AD#5 (11/19) FOR SALE-**100 plus 48"x24"x15" traps Like new/lightly fished 65.00 each Text Bill @ 774-264-0083

**AD#6 (11/19) FOR SALE-**32 "Lobster Boat -Fiberglass Maine lobster or tuna boat Holland 1984. 454 gasoline engine 3 years old, 12" pot hauler. Currently used for lobster fishing everyday. New boat coming, must sell. 28,000.00 Call 978-884-2988

**AD#7 FOR SALE-** BUNGEE CORD ON SPOOLS. Made in New England area. Call Jonathon "Mr. Bungee" 401-447-7973 or [Jon@marineropeinternational.com](mailto:Jon@marineropeinternational.com) 5/16" x 300'ft \$35.00/spool 5/16"x 500'ft \$50.00 spool All sizes, colors to choose from. Located in Cranston, RI

**AD#8 (11/19) FOR SALE-** Area 1 lobster license-approx; 75 traps, 19ft Midland 70 HP Suzuki 4 stroke & trailer. Asking \$24,000 Call Pat@978-879-9623

**AD#9 (1/20) FOR SALE-** 200 Used Pono's -3 footers- hoop gear-shrimp mesh heads. All in great shape. Some \$30 & \$40-multiple colors. Call Matt @ 339-613-7122

**AD#10 (2/20) FOR SALE-**1997 Mariner Commercial 55 hp o/b motor Rope Start, Tiller Model, Long Shaft Been in storage for 6 yrs Has a replacement lower unit\$10002001 Tohatsu 18 hp 2 stroke o/b motor Rope Start, Tiller model, Short Shaft Been in storage 3 yrs \$800 Call (508)-246-4009

**AD#11 (1/20) FOR SALE-** MA Coastal Lobster Permit Area 1, transferable, 800 trap allocation. 25ft Nth. Edge lobster boat, Volvo 5L gas, 270hp, Volvo I/O, trailer, 120 3ft traps, \$52,000 or B/O 781-812-6870

**AD#12 (1/20) FOR SALE-** MA State Coastal Lobster Permit Area 1 800 trap allocation, has great history. Asking \$20,000 Call/Text Frank @ 978-807-0301

**AD#13 (2/20) FOR SALE-** Older manual shell fish scale \$500. Call AI @ 508-280-3038

**AD#14 (11/19) FOR SALE-**Gillnet Gear 24" Crosley lifter, roller/alum picking table & s.s.alum mounting brackets/ss spreader bar. 6- seaplast #660 vats 12-steel disk anchors 70-80 lbs 95 monk nets 10",11",12"40-round fish nets 6.5",7",7.5"Would like to sell as a package \$24,500. Text Bill 774-264-0083

**AD#15 (2/20) FOR SALE-**Tuna tower & pulpit 22ft both have hinges \$1,000. Call AI @ 508-208-3038

**AD#16 (2/20) FOR SALE-**301-2-F Transmission 2 point 69 to 1/\$1,000. OBRO Call Skip 781-844-8162

**AD#17 (9/19) FOR SALE-**State coastal lobster permit-100+traps, lines & buoys. \$18,000.00 617-846-3714@5:00 P.M.

**AD#18 (2/20) FOR SALE-**" 8.2 Detroit Diesel - 320 HP with after-cooler, running takeout with Borg Warner transmission, runs great, no smoke. have video of engine running and wet exhaust - \$3,000.00 Also, spare 8.2 Detroit Diesel, (rebuilt by Lew Bacon) with Twin Disc transmission and spare starting motors - \$3,000.00 Located in Gloucester Call / text Dave at 603-422-4335

**AD#19 (2/20) FOR SALE-PLACE YOUR AD HERE**

**AD#20 (2/20) FOR SALE-**Gill net lifter, Bandolier style, new \$1,000.00-Mantis style shrimp dredging gear -net culling table- 2 vats-plumbed circulation W/ trailer \$1,500.00- Propeller 34x34, right hand 2 1/2 in bore-4 blade-\$1,500.00-3/4 net chain sweep W/5in Cod end\$500.00 - 6 new gill nets W/ 6in mesh\$200.00 each & misc: nets Call Bill @ 508-264-1076

**AD#21 (1/20) PLACE YOUR AD HERE**

**AD#22 (8/19) FOR SALE-** 100 traps 48" yellow double parlor Good shape. \$ 40.00 firm. Serious inquiries only. Call/leave message No calls after 6 p.m. Mike 781 249 2818

**AD#23 (2/20) FOR SALE-** MA Coastal Lobster Permit Area 1 800 trap allocation asking \$30,000. Or B/O John Moran 401-525-0981

**AD#24 (2/20) FOR SALE-**34" Aluminum Lobster boat CAT 3208T (320hp) built by Gladding & Hearn 1982. 14" hauler & hydraulic wash-down pump asking \$ 90,000 or B/O- MA Coastal Area 1 Lobster Permit w/800 trap allocation. John Moran 401-525-0981

**AD#25 (10/19) FOR SALE-** 25 ft BHM 180 HF 453T Detroit engine-600 hrs. on rebuilt engine. Furuno radar-new- 4ft extended hull Garmin plotter-new 2 Furuno GPS Sitex depth finder- Auto-pilot VHF radio CB radio New hydraulic steering- new wash down pump-dripless shaft bearing-new battery-new alternator-bilge alarm 150 gal., fuel tanks-14ft deck area- 2 propellers-Fished daily. \$23,500 or \$37,500.00(w/ dragging gear) Call Frank @ 203-868-8481

**AD#26 (2/20) PLACE YOUR AD HERE**

**AD#27 (2/20)-**Scallop quota available for leasing -e-mail [hiflyer2@verizon.net](mailto:hiflyer2@verizon.net)

**AD#28 (2/20) HELP WANTED-**Sternman/Commercial Lobsterman Position. Experience Preferred but not necessary. If dedicated, honest and hardworking I will train. Must have own transportation and be Drug Free. Gloucester. Robert @ 617-417-9630

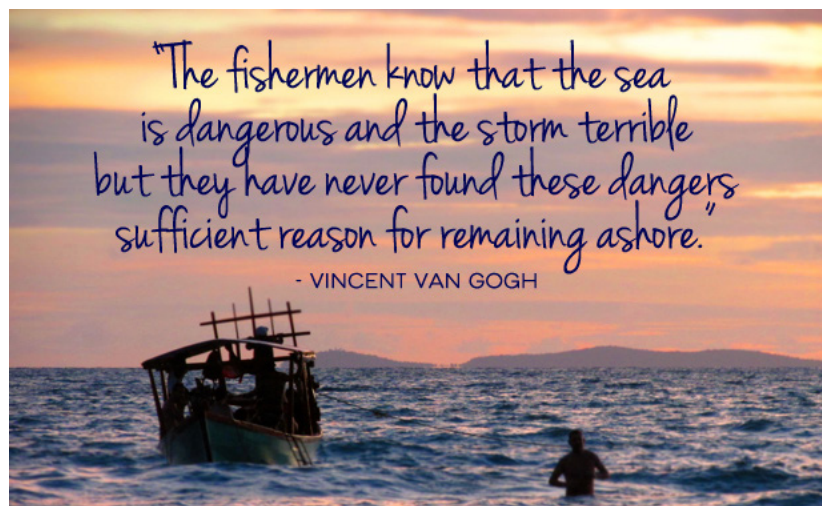



***Cape Seafoods Bait Shop  
Kicking off the Season!***



**THE LARGEST BAIT VARIETY IN THE ATLANTIC NORTHEAST**

*In operation since 2001 and still going strong!*

**Trust Us for Your Fresh, Salted & Frozen Bait Needs**

**From (1) Carton to a Full Truck Load.**

**Herring, Mackerel, Pogies, Redfish, Rockfish, Tuna, Monkfish, Sardines,  
Plaice, Squid, Sea Robin, Halibut, & Silversides.**

**We've got you covered!**

**Great News...We now buy Lobster, too!**

**Open Year Round (Serving clients 7 Days a Week from Mid-June To Mid-October)**

**Monday-Friday 5AM-3PM, Saturday 6AM-12PM & Sunday 6AM-10AM**

**Main Phone Line: 978.283.8522**

**Bait Shop Phone Line : 978.479.4642**

***If we don't have it... Please ask and we'll find it!***

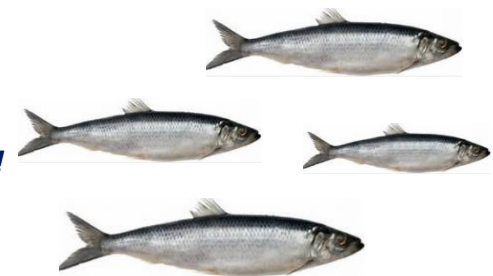

# ANNUAL WEEKEND 2020 EVENTS



Free Drawing

## MLA Grand Banquet & MLA Awards Ceremony

Saturday evening ~ 6:30 pm

**"Bass River"**

Don't forget to bring your Pre-paid dinner tickets with you.



5 Merry Weekend Getaways at the Resort and Conference Center at Hyannis & Cash prizes all to be Drawn at the Banquet and You must be present to win.

**"CRAFT"**

**SATURDAY 10:00**

Barnstable III



Come have a fun time making a beautiful and edible arrangement with Pam Bartlett. Pam has made many of these delicious bouquets and is looking forward to showing you how you too can brighten up someone's day! These delicious arrangements are a great way to show someone how much they mean to you. Flowers are great but, sweets are better.

Sign up at the MLA booth as space is limited. We are looking forward to seeing you there!

*(the image is just a sample)*



When: Friday & Saturday  
Time: 6:00 pm—11:00 pm  
Where: Hyannisport West



Once again, there will be age appropriate activities and movies. Pizza will be served Friday night and Saturday will be chicken nuggets and French fries along with non-caffeinated beverages and dessert. Do not forget to pre-register your child at the MLA booth. All children MUST be picked up by 11:00 PM. Thank you!

# Casino Night



Blackjack

Saturday Night

Barnstable II

9:00pm-11:00pm

Money Wheel

Wax & Jingles

## 50-50 Raffle



Pot'O Gold

Drawn every 15 minutes



OVER 20 YEARS EXPERIENCE ~ ALL MATERIALS & SIZES

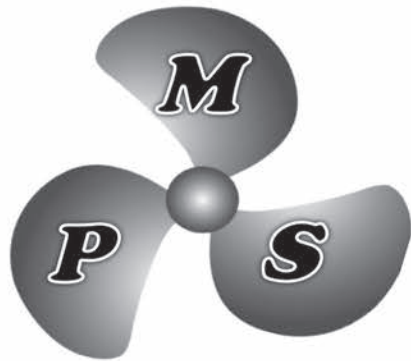

# MARINE

PROPELLER SERVICE

**FOR FAST SERVICE  
CALL MIKE @  
508.979.8000**

**REPAIRS &  
RECONDITIONING**  
(Fast & Fully Insured)

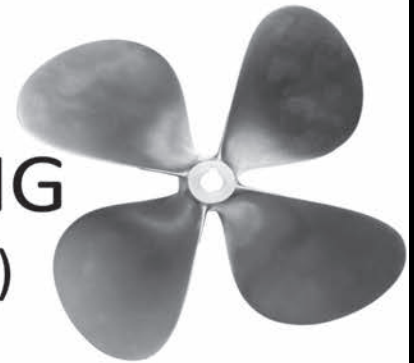

marine.propeller128@gmail.com

*THE MOST RELIABLE PROPELLER SERVICE COMPANY ON THE SOUTHCOAST*

**74 MAIN STREET FAIRHAVEN MA 02719 508.979.8000 FAX 774.206.6449**



**“Specializing in the sale & delivery of  
LOBSTER BAIT  
for over 30 years”**

**FRESH FROZEN AND SALTED BAIT AVAILABLE**

**SKATES ~ HERRING ~ POGIES ~ HADDOCK ~ COD FISH  
POLLOCK ~ FLAT FISH ~ FISH SKINS ~ RED FISH  
DOG FISH HEADS ~ SALMON**



**C & P BAIT  
33 Wright St  
New Bedford, MA 02740**

**Contact:  
Danny Costa 508-951-9818  
Carlos Pereira 508-951-9819**

F E B R U A R Y 2 0 2 0

**MASSACHUSETTS LOBSTERMEN'S ASSOCIATION, INC.  
SCHOLARSHIP AWARD APPLICATION 2020  
IN MEMORY OF ROBERT A. WHEELER**

This application should contain accurate and detailed information and be accompanied by a copy of your official high school transcript that is signed and sealed.

Name: \_\_\_\_\_

Home Address \_\_\_\_\_

City/Town: \_\_\_\_\_ State \_\_\_\_\_ Zip \_\_\_\_\_

Father, Mother and/or guardian's Name: \_\_\_\_\_ Occupation \_\_\_\_\_

Are they a current member of the Mass. Lobstermen's Association? [ ] Yes [ ] No

Are both parents living? [ ] Yes [ ] No

Number & Ages of siblings living at home: \_\_\_\_\_

Do you have anyone financially dependent upon you? [ ] Yes [ ] No

If yes, please explain: \_\_\_\_\_

How much financial aid is expected in your first year of college / trade school: \_\_\_\_\_

Name of High School and year of graduation: \_\_\_\_\_

Name of college or trade school you expect to enter: \_\_\_\_\_

Have you been accepted for admission: \_\_\_\_\_

What is your anticipated tuition: \_\_\_\_\_

Have you received any other scholarships - If yes, state amount(s): \_\_\_\_\_

What business or profession do you expect to prepare for: \_\_\_\_\_

What extra-curricular activities have you participated in: \_\_\_\_\_

REFERENCES: **Please enclose any letters of recommendation and at least two** from the following choices: School Principal, Guidance Counselor, Instructor in your major, Pastor or Minister.

Please write a short paragraph explaining why you are interested in your field of endeavor:

\_\_\_\_\_

\_\_\_\_\_

\_\_\_\_\_

\_\_\_\_\_

\_\_\_\_\_

\_\_\_\_\_

\_\_\_\_\_

\_\_\_\_\_

SCHOLARSHIPS ARE AWARDED AT THE DISCRETION OF THE  
SCHOLARSHIP COMMITTEE.  
ALL DECISIONS ARE FINAL

SIGNATURE: \_\_\_\_\_ DATE: \_\_\_\_\_

***THIS APPLICATION MUST BE RETURNED BY APRIL 15<sup>th</sup>***

Mail applications to:  
Massachusetts Lobstermen's Assoc.,  
Scholarship Committee  
8 Otis Place, Scituate, MA 02066.



**Bottom Line**  
**Super 46 Wesmac**  
**C18 CAT**



# WHEN YOUR ENGINE MEANS BUSINESS, MILTON CAT MEANS MORE.

Milton CAT is the Northeast and upstate New York Caterpillar dealer. Our complete range of marine power systems solutions is backed by a team with exceptional knowledge and experience.

- More engine choices.
- More fully equipped and staffed locations.
- More support for your commercial fishing vessel, ferry, tug, or pleasure craft.



**Stock and Custom-Built Traps  
Lobster and Specialty Traps  
Aquaculture Supplies  
Huge Inventory of Commercial  
Fishing Supplies  
Four Locations in Maine**



**BROOKSTRAPMILL.COM  
(800) 426-4526**